

# Guidelines for Space Systems Critical Gated Events

9 May 2008

William F. Tosney<sup>1</sup>, Paul G. Cheng<sup>2</sup>, and Jeff B. Juranek<sup>3</sup>

<sup>1</sup>Corporate Chief Engineering Office, Systems Planning and Engineering; <sup>2</sup>Mission Assurance Subdivision, Systems Engineering Division, Engineering and Technology Group; and <sup>3</sup>Product and Process Assurance Department, Mission Assurance Subdivision, Systems Engineering Division, Engineering and Technology Group

Prepared for:

Space and Missile Systems Center  
Air Force Space Command  
483 N. Aviation Blvd.  
El Segundo, CA 90245-2808

Contract No. FA8802-04-C-0001

Authorized by: Systems Planning and Engineering

APPROVED FOR PUBLIC RELEASE



# Guidelines for Space Systems Critical Gated Events

9 May 2008

William F. Tosney<sup>1</sup>, Paul G. Cheng<sup>2</sup>, and Jeff B. Juranek<sup>3</sup>

<sup>1</sup>Corporate Chief Engineering Office, Systems Planning and Engineering; <sup>2</sup>Mission Assurance Subdivision, Systems Engineering Division, Engineering and Technology Group; and <sup>3</sup>Product and Process Assurance Department, Mission Assurance Subdivision, Systems Engineering Division, Engineering and Technology Group

Prepared for:

Space and Missile Systems Center  
Air Force Space Command  
483 N. Aviation Blvd.  
El Segundo, CA 90245-2808

Contract No. FA8802-04-C-0001

Authorized by: Systems Planning and Engineering

APPROVED FOR PUBLIC RELEASE

# Guidelines for Space System Critical Gated Events

Approved by:

A handwritten signature in black ink, reading "William F. Tosney". The signature is written in a cursive style and is positioned above a horizontal line.

William F. Tosney, Corporate Chief  
Engineer/General Manager  
Corporate Chief Engineering Office  
Systems Planning and Engineering

## Abstract

Painful experiences learned in the 1990s taught the space community that mission assurance (MA) must receive the highest attention. To that end, industry and government have formed the Space Quality Improvement Council (SQIC) to proactively enhance collaboration to improve processes that facilitate a common approach to mission assurance where applicable.

In the space industry, critical gates and the criteria for those gates vary widely across the customers, programs, and contractors. Often, space products move to the next phase of the lifecycle without attaining an appropriate level of maturity. Significant mission and programmatic risk is incurred throughout the program lifecycle by inconsistent processes, terminology, and criteria of the gated review process. By establishing a common set of “gated events” used across the space industry – common gates, objectives, and entrance and exit criteria would serve to align government and contractors regarding:

- What constitutes the critical points in the lifecycle
- High-level requirements via entrance and exit criteria
- Establishment of a common vernacular to eliminate confusion about objectives and criteria

For this particular topic on space systems critical gated events, an industry and government team has been formed with the charter to define common gates, objectives, entrance and exit criteria. Throughout the year, the Space Systems Gated Events Team will status and report back to the SQIC, and present a shared roadmap and a draft guidance document that was presented at the SQIC Workshop in May 2008. A final guidance document will be presented to government and industry at a national aerospace symposium later in 2008.



## **Acknowledgments**

The *Guidelines for Space Systems Critical Gated Events* was created by many authors throughout government and industry. We especially thank the following contributing authors for making this collaborative effort possible: Rebecca T. Ashley, Eva V. Carrillo, and Kimberly B. Levine of Boeing Space and Intelligence Systems; Emily P. Friedman and Charles L. Kelly of Raytheon Space and Airborne Systems; Paula M. Greene of Ball Aerospace and Technologies Corp.; Helen B. Gjerde of Lockheed Martin Space Systems Corp.; Don McAlister and Fernando R. Vivero of Pratt & Whitney Rocketdyne, United Technologies; Bill McMullen of Northrop Grumman Space Technology; and Lt. Col. John Varljen of SMC.





# Contents

1.	Introduction.....	1
1.1	Problem Statement .....	1
1.2	Recommendation .....	1
1.3	Definitions.....	2
2.	General.....	5
2.1	Tailoring.....	5
2.2	Application Guidance .....	5
2.3	Administration of Technical Reviews.....	13
2.4	Work Product Matrix .....	15
3.	Gate 1: Requirements Review .....	17
3.1	Introduction.....	17
3.2	Purpose.....	17
3.3	Entrance Criteria .....	17
3.4	Exit Criteria.....	18
3.5	Work Products .....	19
3.6	References .....	23
4.	Gate 2: Preliminary Design Review (PDR).....	25
4.1	Introduction.....	25
4.2	Purpose.....	25
4.3	Entrance Criteria .....	25
4.4	Exit Criteria.....	25
4.5	Work Products .....	28
4.6	References .....	32
5.	Gate 3: Critical Design Review (CDR) .....	35
5.1	Introduction.....	35
5.2	Purpose.....	35
5.3	Entrance Criteria .....	36
5.4	Exit Criteria.....	36
5.5	Work Products .....	39
5.6	References .....	43
6.	Gate 4: Build Readiness Review (BRR).....	45
6.1	Introduction.....	45
6.2	Purpose.....	45

6.3	Entrance Criteria.....	45
6.4	Exit Criteria .....	46
6.5	Work Products .....	46
6.6	References .....	49
7.	Gate 5: Test Evaluation Campaign Review (TECR).....	51
7.1	Introduction .....	51
7.2	Purpose .....	52
7.3	Entrance Criteria.....	53
7.4	Exit Criteria .....	53
7.5	Work Products .....	54
7.6	References .....	57
8.	Gate 6: Assembly/Integration Readiness Review (BIST RR).....	59
8.1	Introduction .....	59
8.2	Purpose .....	59
8.3	Entrance Criteria.....	59
8.4	Exit Criteria .....	61
8.5	Work Products .....	61
8.6	References .....	64
9.	Gate 7: Pre-Environmental Review (PER).....	67
9.1	Introduction .....	67
9.2	Purpose .....	67
9.3	Entrance Criteria.....	67
9.4	Exit Criteria .....	69
9.5	Work Products .....	69
9.6	References .....	72
10.	Gate 8: Pre-Ship Review (PSR) .....	75
10.1	Introduction .....	75
10.2	Purpose .....	76
10.3	Entrance Criteria.....	76
10.4	Exit Criteria .....	76
10.5	Work Products .....	77
10.6	References .....	80
11.	Gate 9: Mission Readiness Review (MRR) .....	82
11.1	Objective.....	82
11.2	Entrance Criteria:.....	82

11.3	Exit Criteria.....	82
11.4	Work Products .....	84
11.5	References .....	87
12.	Gate 10: Flight Readiness Review (FRR).....	88
12.1	Introduction.....	88
12.2	Purpose.....	88
12.3	Entrance Criteria .....	90
12.4	Exit Criteria.....	91
12.5	Work Products .....	91
12.6	References .....	95
13.	Gate 11: Initial Checkout Review (ICR) .....	96
13.1	Introduction.....	96
13.2	Purpose.....	96
13.3	Entrance Criteria .....	96
13.4	Exit Criteria.....	96
13.5	Work Products .....	97
13.6	References .....	100
14.	Work Product Matrix.....	101
15.	Acronyms and Abbreviations .....	127
	Appendix: Suggestions for Improving RFPS and Source Selection Process .....	129

## Figures

Figure 1. Critical Gated Events .....	2
Figure 2. Notional space system program. ....	6
Figure 3. Gated event relationship to other space systems reviews. ....	7
Figure 4. Gated event sequencing – timing is notional, activities may overlap phase. ....	8
Figure 5. Requirements reviews. ....	8
Figure 6. Test evaluation campaign (TEC). ....	9
Figure 7. Pre-ship review (PSR). ....	10
Figure 8. Mission readiness review (MRR). ....	10
Figure 9. Flight readiness review (FRR). ....	11
Figure 10. Key dependencies between design gated events and build and test gated events. ....	12
Figure 11. Key dependencies between early gated events and late gated events. ....	13
Figure 12. Work product matrix checklist. ....	16
Figure 13. Satellite Workflow from Consent-to-Ship to On-orbit Operations .....	88

## Tables

Table 1. Work Product Matrix Detail #1 .....	20
Table 2. Work Product Matrix Detail #2 .....	29
Table 3. Work Product Matrix Detail #3 .....	39
Table 4. Work Product Matrix Detail #4 .....	46
Table 5. Work Product Matrix Detail #5 .....	54
Table 6. Work Product Matrix Detail #6 .....	61
Table 7. Work Product Matrix Detail #7 .....	69
Table 8. Work Product Matrix Detail #8 .....	77
Table 9. Work Product Matrix Detail #9 .....	84
Table 10. Baseline Tasks for Nominal Satellite Processing from Factory to Operations .....	89
Table 11. Work Product Matrix Detail #10 .....	91
Table 12. Work Product Matrix Detail #11 .....	97

# 1. Introduction

Space systems critical gated events are reviews conducted at key points in the program lifecycle to evaluate:

- Program technical maturity
- Program risks and opportunities
- Challenges associated with the next phase of the program
- Stakeholder expectations
- Program readiness for the next phase

Clear gate objectives and entrance and exit criteria are established to help reviewers determine if the program and its products are mature enough to proceed to the next phase of the lifecycle. Key milestones in Space Systems Development programs include design; development; manufacturing, assembly, integration, and test; launch and deployment; and final operation. Gated reviews provide an opportunity to both leverage and collect lessons learned.

Gated review events are integral pieces to a successful mission campaign and are applicable to all components, assemblies, and systems of the mission's value chain. Tailoring of these milestone reviews to accommodate lower-tier components, assemblies and system requirements is permitted.

## 1.1 Problem Statement

Inconsistent application of gated reviews has shown to significantly increase a program's susceptibility to mission and programmatic risks. The problem is manifested by a program unknowingly moving to the next phase of its lifecycle without first attaining an appropriate level of maturity or identification and full understanding of risks.

## 1.2 Recommendation

The current space industry's gated acquisition cycle process would be streamlined and better understood by both customer and contractor through the establishment of a common definition of gated events (see Figure 1). Common gates, objectives, and entrance and exit criteria would serve to align government and contractors regarding:

- What constitutes the critical points in the lifecycle
- High-level requirements via entrance and exit criteria
- Establishment of a common vernacular to eliminate confusion about objectives and criteria

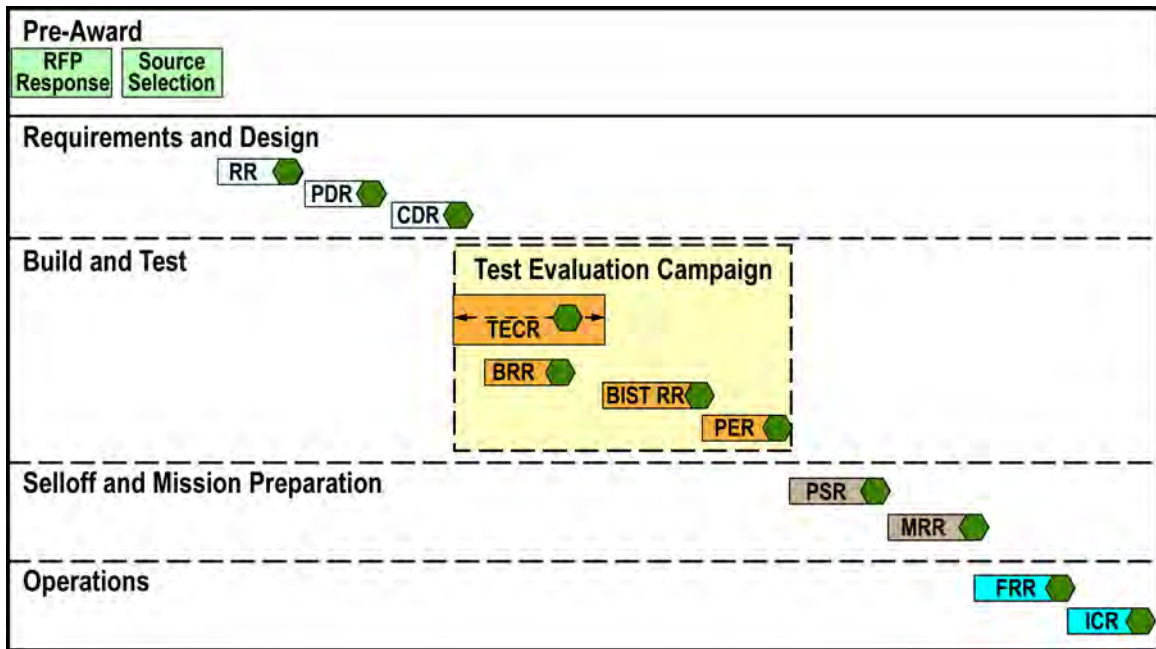

0283-08

- |   |                                    |
|---|------------------------------------|
| 1 – Requirements Review (RR)                            | 7 – Pre-Environmental Review (PER) |
| 2 – Preliminary Design Review (PDR)                     | 8 – Pre-Ship Review (PSR)          |
| 3 – Critical Design Review (CDR)                        | 9 – Mission Readiness Review (MRR) |
| 4 – Build Readiness Review (BRR)                        | 10 – Flight Readiness Review (FRR) |
| 5 – Test Evaluation Campaign Review (TECR)              | 11 – Initial Checkout Review (ICR) |
| 6 – Baseline Integrated Test Readiness Review (BIST RR) | ● Actual Review                    |

Figure 1. Critical gated events

### 1.3 Definitions

**Gated Events:** A review in the product lifecycle where technical maturity is assessed and the risk of proceeding is identified classified understood classified and communicated.

**Segment:** A major subassembly, subsystem, or structure that when assembled and integrated with other subassemblies, subsystems, and/or structures, results in a complete system.

**System Requirements Review (SRR):** The SRR demonstrates that mission- and system-level requirements, specification, and architectures are understood, are adequately defined, and meet mission/program objectives. MA Focus is on requirements related to Reliability, System Safety, Environmental Engineering, EEE Parts, Materials, and Processes, Hardware Quality Assurance (HQA), and Software Quality Assurance (SQA).

**System Design Review (SDR):** The SDR is the formal assessment of architecture/design and validation allocation of requirements for optimization, traceability correlation, completeness, and minimization of risk. MA Focus is on proper allocation, flow down, and cross-validation of requirements related to Reliability, System Safety, Environmental Engineering, EEE Parts, Materials, and Processes, HQA, and SQA.

**Preliminary Design Review (PDR):** The PDR evaluates the contractor’s technical adequacy, progress, and risk resolution for the selected design-to approach for all configuration items (CIs), and establishes a CI design baseline down to the assembly level. The PDR demonstrates design compatibility with the

performance and engineering specialty requirements of the hardware development specifications. Included is an evaluation of technical risks associated with the manufacturing process/methods and the establishment of the compatibility of the physical and functional interfaces among and between CIs (e.g., units, subsystems, or system), facilities, computer software configuration items (CSCIs), and personnel. The PDR processes allow for an engineering assessment of the technical adequacy of top-level design, testing approach, and concepts of operation (CONOPS). PDRs are normally conducted once per program for each CI at the assembly level, subsystem, element, and segment, building to the system level as appropriate.

Critical Design Review (CDR): The CDR evaluates the contractor's detailed system design and the detailed build-to design for each CI and aggregation of CIs in the specification tree to determine if each design meets the allocated functional, performance, and engineering specialty requirements. The CDR also is used to evaluate whether the design can be produced and verified, has interface compatibility between CIs/CSCIs, facilities, and personnel, and that all risks have been identified, rated, and satisfactory mitigation plans established. CDRs are normally held once per program for each CI (assembly level), subsystem, element, and segment, building to a system level as appropriate.

Build Readiness Review (BRR): The BRR determines the readiness of the manufacturer/contractor to proceed with the manufacturing of the product. The review is held incrementally in preparation for the production of the CI, subsystem, and system. Specifically, the BRR is intended to: 1) identify incomplete design elements and ensure risk mitigation plans are in-place, 2) verify the design is producible and producibility-oriented changes are incorporated into the design, 3) production build history documentation is defined, and production planning for capacity and throughput is balanced, 4) production processes and methods are consistent with quality requirements and compliant with Environmental Health & Safety regulations, 5) production flight parts/materials are qualified and received into stores – including spares/safety stock and available to meet the production plan, 7) facilities are allocated and qualified, 8) personnel are trained, certified, and assigned to the effort, and 9) all tooling and ground support equipment (GSE) including test equipment is certified/calibrated/proof-loaded and ready-for-use. The BRR will also reveal whether issues, risks, and corrective actions for manufacturing have been satisfactorily resolved prior to start of production.

Test Evaluation Campaign Review (TECR): The TECR verifies that the program/project is prepared to proceed with formal testing; it is a gated review held within the overall Test Evaluation Campaign (TEC). The TEC itself is not one gated event but a series of reviews held during the manufacturing, build, and test phase of a program and includes the test readiness at TECR, Baseline Integrated Systems Test (BIST), Pre-Environmental Review (PER), and lower-level test readiness reviews held at the discretion of the program. The TECR review verifies that the planned testing meets all assigned verification or validation requirements and verifies that the test documentation, test hardware, test software, and test resources are ready for test operations. At the discretion of the program/project, it may be held in association with the CDR or held prior to testing units, assemblies, subsystems, modules, or the space vehicle. For programs with significant new development or high risk content, more than one TECR may be held.

Baseline Integrated System Test (BIST) Readiness Review (RR): BIST RR evaluates the completeness of the flight system; compatibility between the spacecraft and the payload; the readiness of test facilities, test procedures, and special test equipment to support system level testing; the adequacy of documentation; planning for closure of all remaining problems, waiver or liens; and the readiness of the integration and test team to support system-level testing.

Pre-Environmental Review (PER): The PER is performed before the start of formal environmental testing of the integrated space vehicle to show that, having demonstrated satisfactory baseline performance during initial test, the vehicle has enough margin to permit environmental testing. The PER assessment criteria focuses on the readiness of test facilities, test procedures, and special test equipment to support system-level testing without causing harm.

Pre-Ship Review (PSR): The PSR evaluates the plans and approaches for qualification testing, acceptance testing, analyses, and simulations as they apply to system sell-off. The program conducts PSR to assure that flight hardware and components, software, GSE, and procedural documentation are ready to ship to the deployment site. Operations personnel participate in this review. This type of review is meant to identify any open issues affecting deployment and subsequent operations, verify that planning is in place to close-out these issues in a timely manner, and verify supportability of the program's ensuing activities. Operations personnel ensure sufficient coordination between the system contractor and the Range/launch site (and/or any other receiving site), to assure that the latter is ready to receive program hardware, receiving support has been appropriately scheduled, and receiving facilities are prepared to support hardware arrival and post-shipping inspection activities.

Mission Readiness Review (MRR): The MRR is a formal review to evaluate the readiness of the spacecraft before final launch integration activities are initiated. The mission director, launch program single manager (SM), and appropriate launch base detachment commander may choose to attend. Program and support organization personnel conduct the MRR, which is supported by the appropriate contractors. Findings and deficiencies should be corrected or disposed of before the flight readiness review (FRR) one to two days before launch. The MRR addresses all system components of mission readiness, including status of flight hardware (e.g., spacecraft, launch vehicle, upper stage), launch and support facilities, Range and orbital operations, ground station operations, and the readiness and training of all personnel, including customer elements processing mission data. Successful completion of the MRR results in a decision to ship the launch vehicle or space vehicle to the launch base to begin launch processing (i.e., "consent to ship").

Flight Readiness Review (FRR): The FRR evaluates the system's space flight worthiness. The FRR process provides a summary pre-launch assessment of the readiness status of the total system (space and launch vehicle), the launch facility, Range safety and instrumentation, the Satellite Control Network, the operational mission control station, operations personnel, and other launch or on-orbit support. Launch Decision Authority also verifies the closure of issues and items and determines the readiness status of safety, training, weather, and recovery teams.

Initial Checkout Review (ICR): The ICR is performed after the satellite completes its preliminary early orbit test. The review verifies that the satellite operates as designed, the ground systems are ready to support operations, and the mission data can be distributed to the users.



## 2. General

### 2.1 Tailoring

This document is applicable only to the extent specified in the tasking directive or contract Statement of Work (SOW). Contracts invoking this document will specifically identify the appropriate applicable paragraphs and Appendices, or portions thereof, in the tasking directive or contract SOW. The selection of necessary gate requirements from this document to be applied to a specific program will be tailored to suit the lifecycle phase, complexity, content and scope, size, intended use (including joint and combined interoperability), mission criticality, and logistics support of the CIs.

### 2.2 Application Guidance

This section provides context and guidance for understanding the recommendations of this document. It is intended to identify the relationship between the gated events provided here and the additional reviews and work that are performed based on internal contractor requirements, customer contractual SOWs, or other program needs. This document attempts to address the key needs for successful technical reviews of the space vehicle by defining space systems gated events. Each space system gated event represents a key assessment point in the program where the work necessary for a successful space vehicle development, launch, and mission is reviewed by knowledgeable individuals for appropriate completeness, correctness, maturity, and integration.

The focus of this document is on the technical reviews for the space vehicle itself and the launch and mission of the space vehicle through handoff to the customer. It is understood that the space vehicle exists within a larger system (or segment) that includes other key elements of a space system such as satellite command and control, launch vehicle, launch command and control, ground stations, payload data processing, user terminals, and connectivity to the satellite user community. It is also assumed that for satellite operations to be successful, these additional elements would need to be successfully developed and deployed as well. The focus of this document remains on the space vehicle and its interfaces to the rest of the space system (see Figure 2). Note that this figure is only meant to clarify the scope of this document and not to define the only way to represent a space system program. The definition and name of a segment and the lower-level elements of each segment can vary by program. To simplify the discussion, the only two segments shown here are the space segment and ground segment (rather than showing a separate “launch segment” or “user segment” or using other terminology such as “control segment”). In addition, the satellite operations aspect (focusing only on the needs of the system to “fly” or “operate” the space vehicle) has been arbitrarily shown under the space segment.

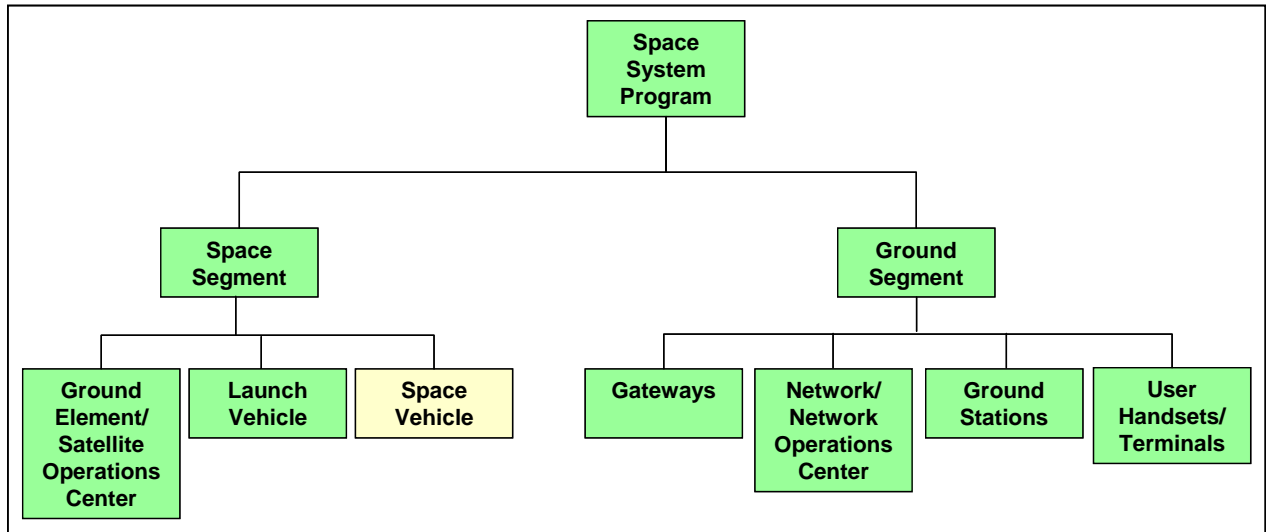

Figure 2. Notional space system program.

This document addresses only those aspects outside the space vehicle itself that were viewed to be critical to the success of the space vehicle. The criteria chosen for each gated event found in this document are focused on the space vehicle, including the launch and mission through deployment of the space vehicle into space and handover to the customer. As such, the gated events exist within the context of a larger system with a presumption that affiliated and lower-level reviews can and will occur as needed with the appropriate handoff and integration between the gated events and the affiliated or lower-level technical reviews. In this context, the affiliated reviews would be those reviews associated with any portion of the system outside the space vehicle itself, its interfaces to the rest of the space system, and its launch and mission through space vehicle handoff including other “segments” and higher-level reviews. “Lower-level reviews” are those reviews focused on the physical or functional decomposition of the space vehicle itself that generally represent a subset of the space vehicle (see Figure 3). Note that this is not meant to imply that there cannot be additional space vehicle reviews outside the gated events defined herein. On the contrary, other space vehicle technical reviews can take place as needed, and a particular gated event can be tailored to be split up into two or more technical reviews or combined with another gated review as appropriate to the program. The program should address the intent of the gated events with the timing and manner appropriate to the program.

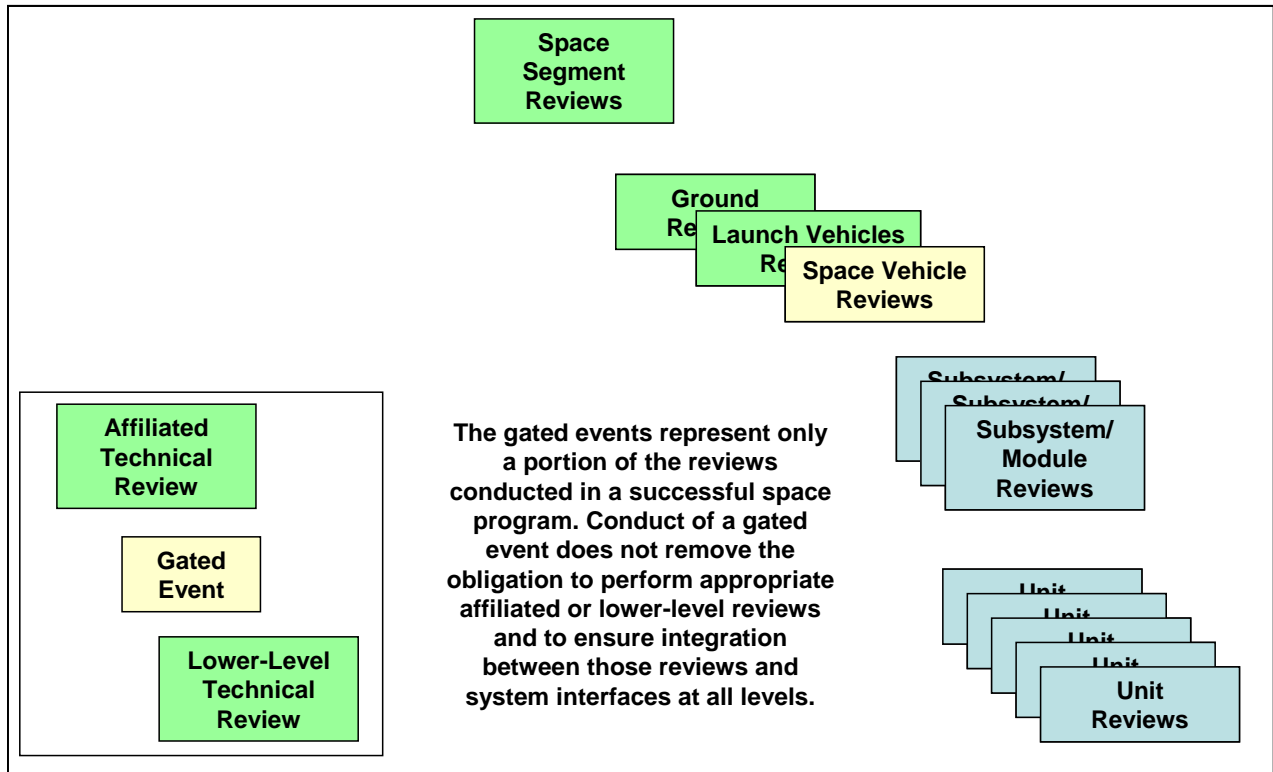
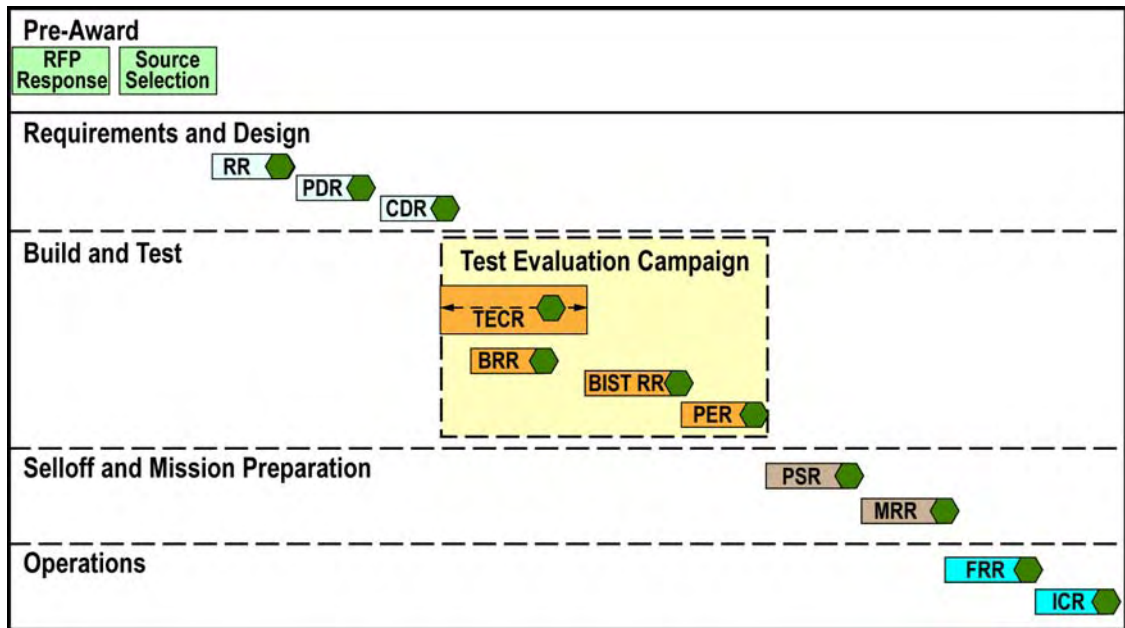

Figure 3. Gated event relationship to other space systems reviews.

As noted in Figure 3, there are many lower-level technical reviews, not all of which are identified in this paper. This document focuses on the space vehicle itself, and for the sake of brevity the details of lower-level reviews which are extremely important to successful completion of the gated events are not generally detailed here. Contractor/supplier relationships and the details of supplier management also are outside the scope of this report. The concept of suppliers to the industry contractors having their own “gated events” is valid and important. As mentioned, this document can be tailored to apply these concepts at other levels of product development than space vehicle production alone.

Figure 4 shows each gated event occurring at the end of a phase of work. The gated events represent both sub-ordinate reviews and the work associated with meeting the criteria of the gated event. The Requirements Review gated event occurs at the end of a phase of work that would include both requirements analysis as well as conducting any affiliated technical reviews. Figure 5 notionally represents a typical “waterfall” of sub-ordinate requirements reviews. It is not uncommon for bilateral impacts to occur across the various levels of reviews (higher-level reviews driving requirements, actions, risks, etc. to lower-level reviews, and vice versa). As an example of how a gated event addresses the integration of the system, the Space Vehicle Requirements Review would ensure that requirements from the greater system were derived, decomposed, and allocated appropriately to the space vehicle. In addition, lower-level requirements that were derived, decomposed, or allocated to lower levels of the space vehicle would be identified as appropriate. While the criteria of the Requirements Review gated event are focused on the space vehicle, the concepts of the Requirements Review are applicable and can be tailored to other levels.



- |   |                                    |
|---|------------------------------------|
| 1 – Requirements Review (RR)                            | 7 – Pre-Environmental Review (PER) |
| 2 – Preliminary Design Review (PDR)                     | 8 – Pre-Ship Review (PSR)          |
| 3 – Critical Design Review (CDR)                        | 9 – Mission Readiness Review (MRR) |
| 4 – Build Readiness Review (BRR)                        | 10 – Flight Readiness Review (FRR) |
| 5 – Test Evaluation Campaign Review (TECR)              | 11 – Initial Checkout Review (ICR) |
| 6 – Baseline Integrated Test Readiness Review (BIST RR) | ● Actual Review                    |

Figure 4. Gated event sequencing – timing is notional, activities may overlap phase.

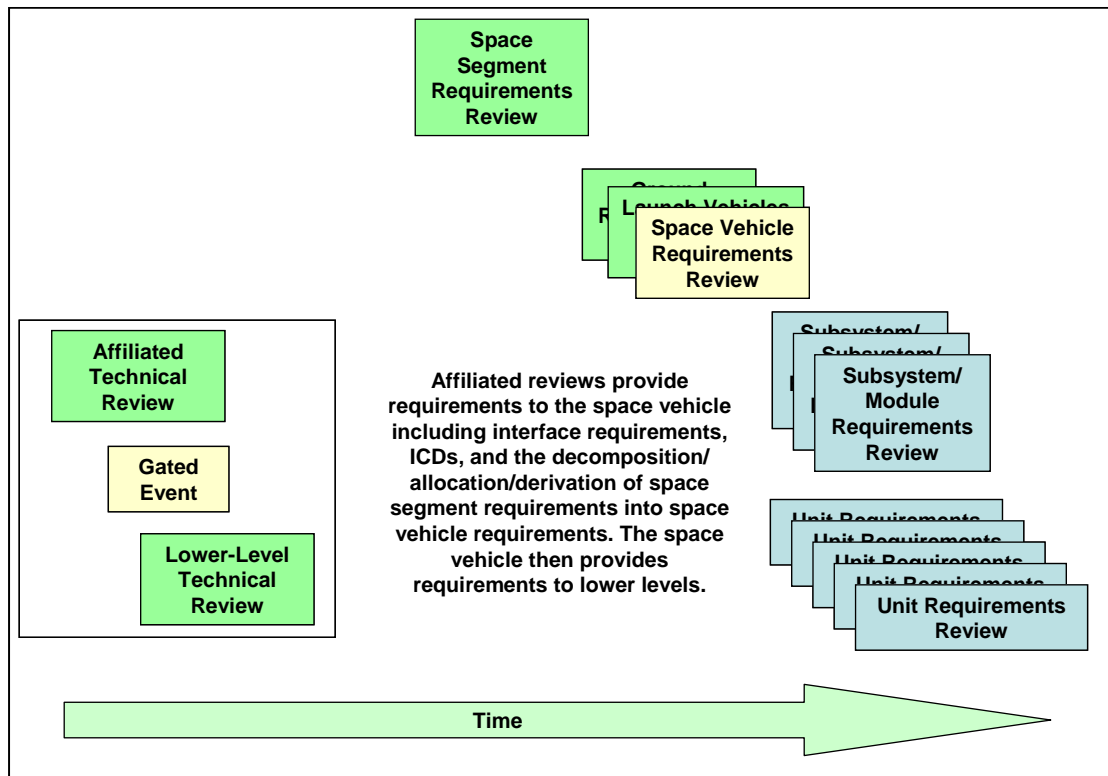

Figure 5. Requirements reviews.

Figure 4 shows PDR and CDR following RR. Each design gated event is preceded by an entire phase of work the culminates in the gated event. Both PDR and CDR occur at levels above and below the Space Vehicle PDR and CDR gated events.

Figure 4 also shows several gated events within the box called “Test Evaluation Campaign.” TEC as referenced in Figure 6 represents an umbrella of activities associated with verification and validation of the space vehicle and encompasses multiple gated events. The TECR is shown as the first review within TEC and is focused on the integration and readiness of the overall test and evaluation campaign. The timing of the TECR will determine whether the TECR addresses more of the planning associated with the test and evaluation campaign or the test and evaluation execution readiness. However, the TECR should be timed to be performed typically after both the program’s strategy for verification and validation (V&V) has been defined and when the plans for how the program will execute V&V are in place. The program will need to balance the timing of TECR with early insight into a program’s plans against the maturity of the work products associated with TEC. This gated event is a candidate for the program to hold several reviews at various time intervals instead of one single review depending on the complexity and criticality of the program’s TEC, as long as the intent of TECR has been met.

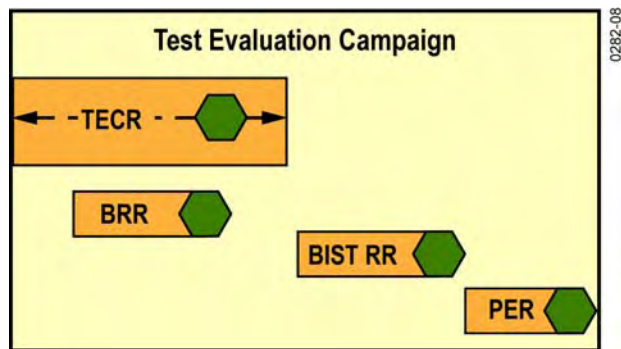

Figure 6. Test evaluation campaign (TEC).

BRR addresses the manufacturing build aspects of the space vehicle as well as how well build plans are integrated and progressing. See the BRR section for more details on its purpose. BIST RR is held after TECR since its purpose is to assess the readiness of the space vehicle and all equipment, facilities, personnel, equipment, procedures, etc., immediately before the phase where power will first be applied for test. Finally, PER is held far enough in advance of when the first major environmental testing occurs to ensure readiness to perform environmental testing on the space vehicle. The timing should be early sufficiently to provide course correction but late enough for the work to be developed enough to assess for the appropriate level of completeness, correctness, maturity, and integration. Depending on the duration of the BIST phase (i.e., a short-duration BIST) and the timing of environmental testing (i.e., immediately following BIST), the BIST RR and PER are candidate gated events to be combined, for example, for an appropriately low-risk program while maintaining the intent of both gated events in a single review.

As mentioned previously, there are many affiliated and lower-level technical reviews not shown here. The TEC is full of additional reviews such as various pre-test and post-test reviews associated with each individual environmental test and all of the lower-level unit pre-test and post-test reviews. The BRR, TECR, BIST RR, and PER are all expected to build on and leverage previous reviews and gated events as well as provide inputs for subsequent reviews, resulting in a fully integrated and successful TEC.

The PSR integrates the results of many affiliated and lower-level technical reviews. Figure 7 shows examples of the types of reviews that provide input to PSR. PSR and MRR are highly coupled and should

be linked by both the data that is shared and the dependencies between the space vehicle itself and its mission/mission products. All data key to PSR is not necessarily shown here. PSR builds on the previous reviews conducted and addresses the flight worthiness of the space vehicle itself. Since the space vehicle design both drives and depends on aspects of the mission, the PSR and MRR complement each other as the program prepares to launch the space vehicle.

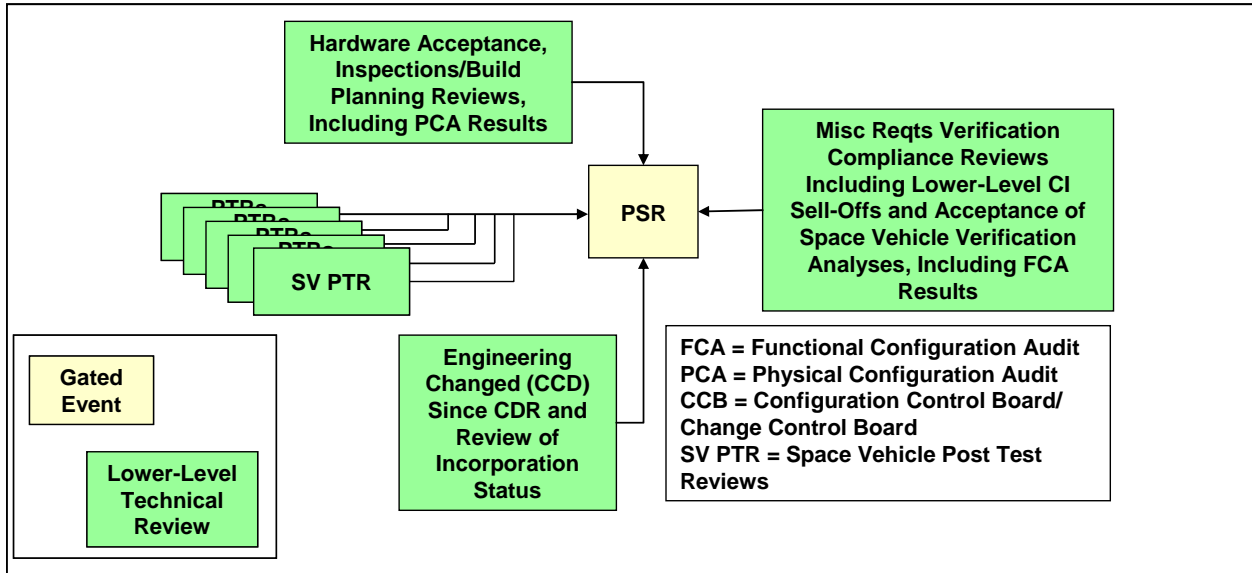

Figure 7. Pre-ship review (PSR).

MRR (see Figure 8) is highly coupled to the PSR, as noted previously. The successful MRR depends on the inputs provided by the many lower-level and affiliated reviews performed prior to a successful MRR. These reviews focus on everything from the readiness of the ground to be able operate the space vehicle to incorporation of changes to the space vehicle since CDR and characterization of the space vehicle that may affect the successful flight and mission.

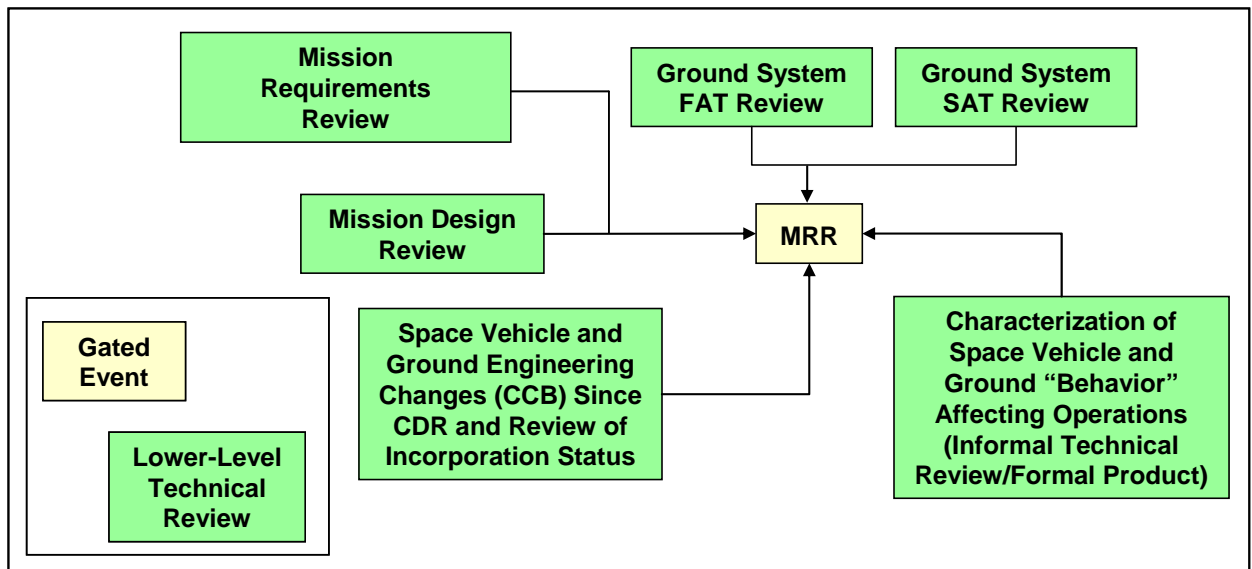

Figure 8. Mission readiness review (MRR).

The Flight Readiness Review (FRR) (see Figure 9) represents the culmination of an umbrella of reviews that would be performed at various stages of the final build up for space vehicle launch and mission. Typically, this review is performed within days of launch and represents the final commitment to launch. Therefore, this is a last chance to ensure that the space vehicle, launch vehicle, and ground system are all ready to support the successful launch, deployment, and mission of the space vehicle.

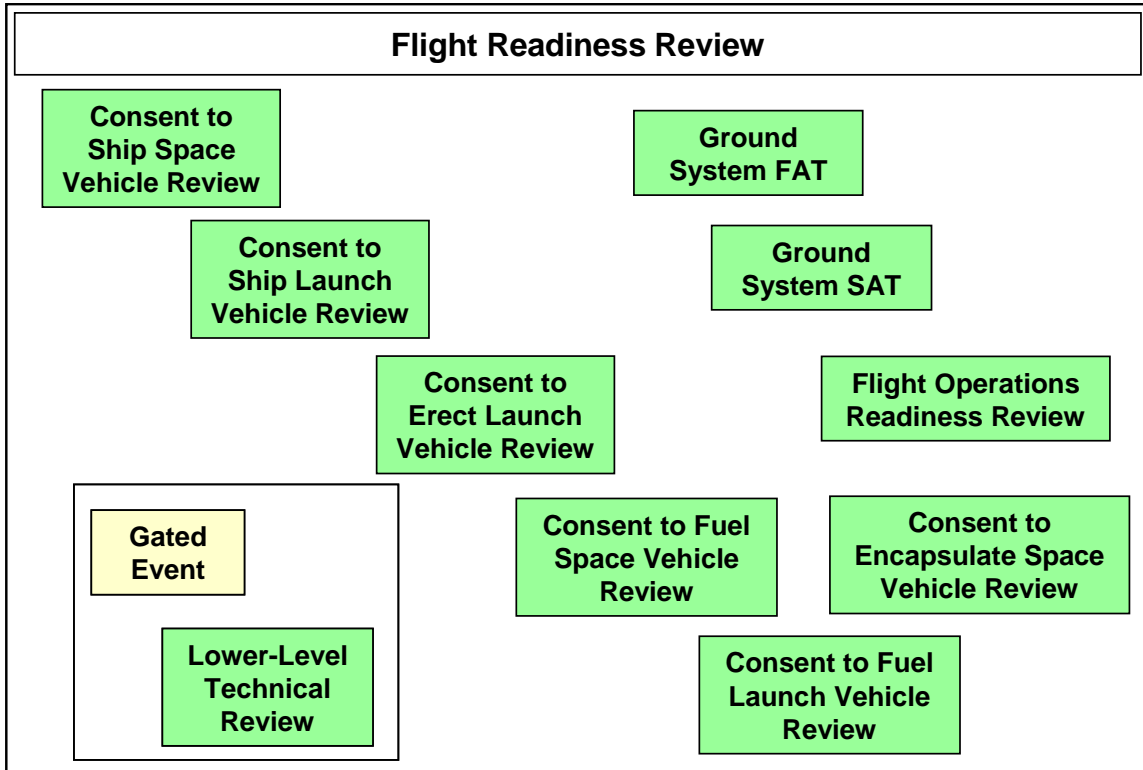

Figure 9. Flight readiness review (FRR).

Finally, ICR provides the final chance for the customer to be assured that the space vehicle has met all of its goals and objectives after being placed in orbit (see Figure 4).

The gated events are dependent upon each other. Often, a key output of a successful gated event becomes a key input to the successful completion of another gated event. If completion of the gated event does not result in confidence that the key dependency has been satisfied to an appropriate level of completeness, correctness, maturity, and integration within the system, the gated event that depends on that output will likely not be successful. For example, the MRR ensures that initial checkout procedures are ready. If the initial checkout procedures are not ready on time, then ICR will likely be delayed or fail until that can be corrected. If the space vehicle Requirements Review does not result in clear, complete, correct, and verifiable requirements along with a design concept and trade studies list that are consistent, the space vehicle PDR will either fail or be delayed until all of this work is completed and results are available. Successful completion of key TEC gated events, including BRR, TECR, BIST RR, and PER, depend on how well space vehicle Requirements Review, PDR, and CDR have resulted in requirements, designs, and plans that support the gated events of TEC (see Figure 10).

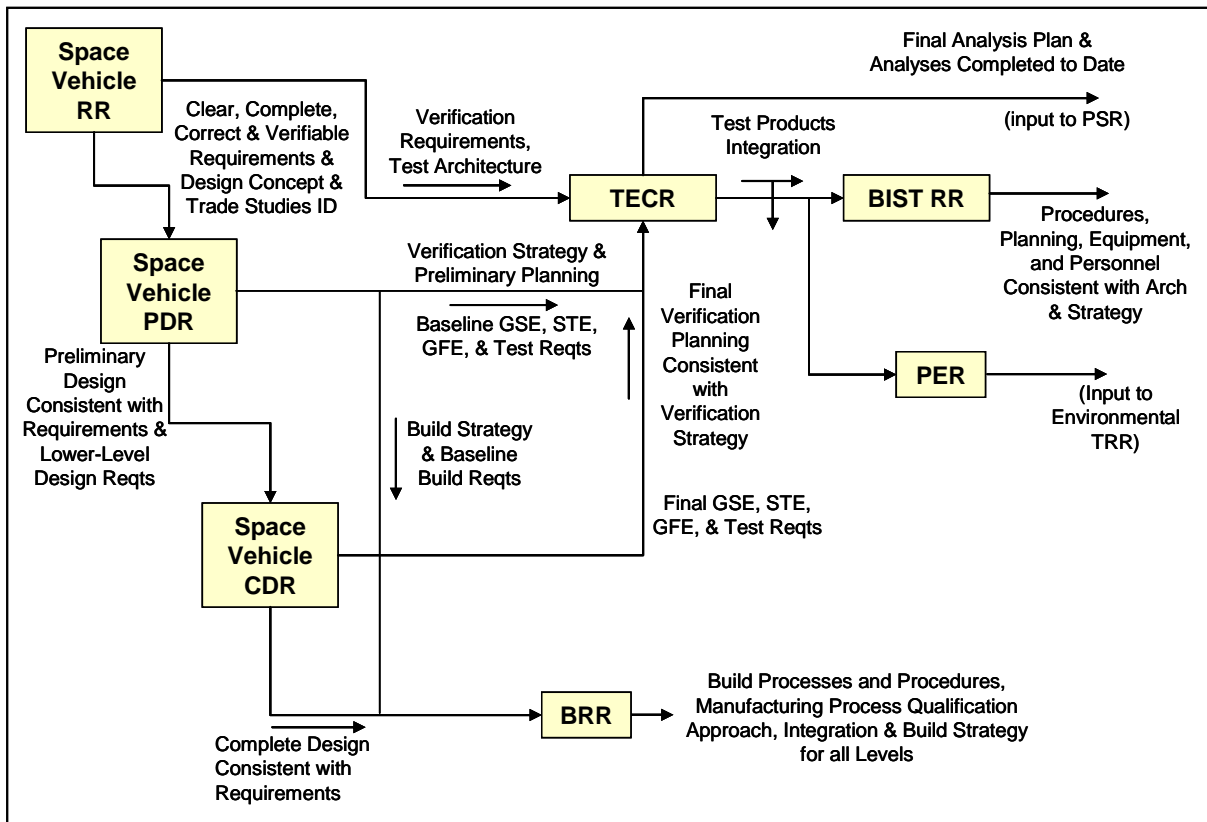
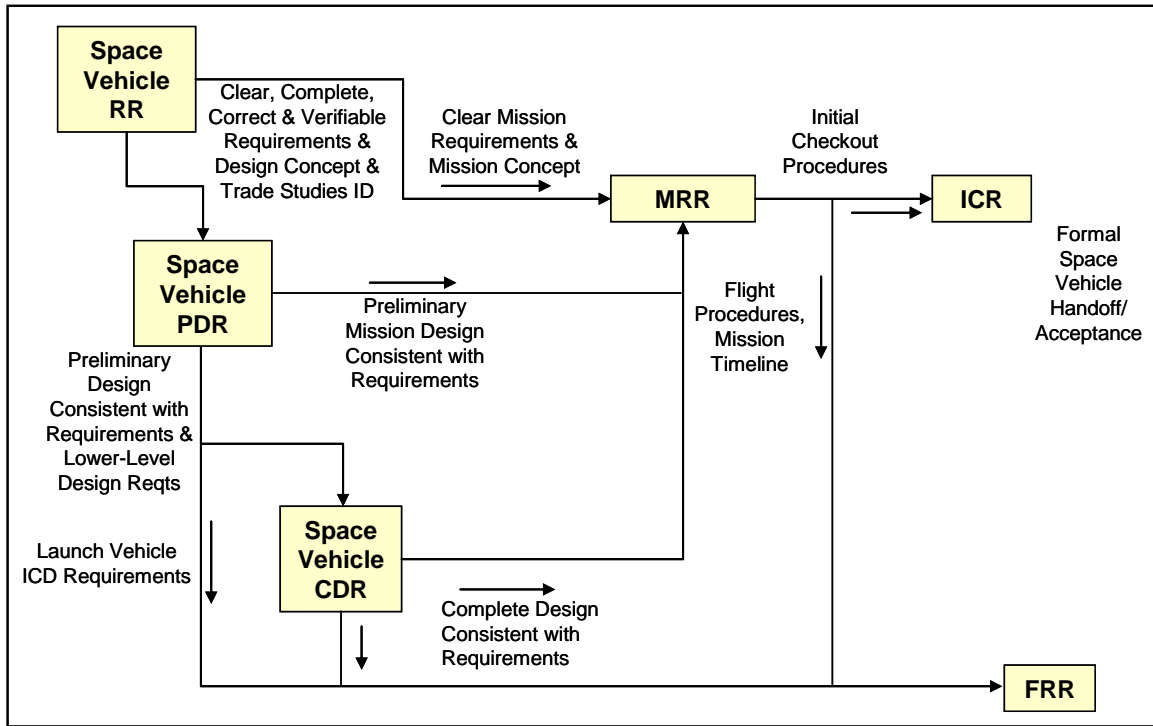

Figure 10. Key dependencies between design gated events and build and test gated events.

Figure 11 represents the key aspects of the space systems program design work that must be mature enough and ready for successful completion of later gated events. For example, the space vehicle requirements, preliminary design, and complete design must mature and be appropriately defined in order to have a successful MRR, FRR, and ICR. Flight procedures and the mission timeline must be mature and ready by MRR for FRR to be successful. ICR, which represents the final gated event before space vehicle handoff to the customer, depends on the successful completion of the space vehicle checkout after launch and deployment. As noted in Figure 11, the MRR ensures that the checkout procedures will be ready for use before they are needed.





Note: See Figure 7 for PSR relationships.

Figure 11. Key dependencies between early gated events and late gated events.

The gated events can be met in a variety of ways and do not stand alone as the only reviews that need to be performed. Rather, they should be considered as the reviews which receive great weight and scrutiny for ensuring the space vehicle is on track and meeting its requirements. The successful completion of the review depends on the determination of whether the work to that point has achieved the goal of being appropriately complete, correct, mature, and integrated within the system. The assessment of “appropriately complete, correct, mature, and integrated” will be determined by the expertise of the individuals assessing the program at each respective gated event. These individuals may be contractor program personnel, customers, and/or consultants as needed. As mentioned earlier, the gated events can be tailored including combining or splitting gated events as long as the intent of each gated event is retained. Finally, there may be additional reviews that should also command greater weight and scrutiny that do not appear in this document. Lack of inclusion here should not imply that these additional reviews are not important.

## 2.3 Administration of Technical Reviews

### 1. Review Panel

The role of the Review Panel is to provide an independent view of the technical state of the program to the program office and its customer. This is accomplished by selection of product, process, and domain experts that will render their evaluation of information presented, and recommend actions for consideration based on the entrance and exit criteria included in this document.

## 2. Panel Roles and Responsibilities

- a. Panel Leader:
- b. The Panel Leader is an individual who is independent of the program being reviewed. The Panel Leader provides overall technical leadership to the Review Panel as well as:
  - Evaluates whether the review entrance and exit criteria are satisfied
  - Assist the program manager in adjudicating acceptance/rejection and priority assignment of all action items assigned during the review
  - Assesses the overall Technical Review after all related briefings are completed
- c. Review Panel Members

The panel members that are selected shall provide an independent view of the specifics under discussion. Members of the panel examine the subject item and associated plans objectively and independently to identify errors and technical risks in hardware, software, and firmware. At minimum the panel shall:

- Examine entrance and exit criteria for the type of review to ensure compliance with customer and process requirements
- Provide to the Panel Leader a summary of findings, categorization of actions, and recommendations for closure of open actions
- Provide technical and briefing support to the panel as a “domain expert”
- Ensure that all pertinent issues and their associated processes are addressed

## 3. Review Grading

- a. For each review a grade shall be issued to the program office in writing by the Review Panel Leader. There are three possible grades:
  - Pass—Releases the program to continue activity to the next milestone. Minor action items have been documented with closure dates.
  - Pass with actions and closure plans—Allows work to continue, except for specific areas with low-to-moderate deficiencies requiring corrective action, under the condition that plans exist to execute the corrective action in the near term. A delta review shall be held to address the corrective action.
  - Fail—Indicates severe deficiencies and the program should be directed to correct the deficiencies before proceeding to the next milestone. A delta review shall be held to review and verify the correction action.
- b. Rationale for pass with actions and closure plans or fail grades shall be documented; all actions that must be closed prior to receiving a grade of pass shall be identified.

## 2.4 Work Product Matrix

Ideally, gated events should be held prior to contractually required reviews to allow sufficient time to correct any major issues. Along with the entrance and exit criteria described in this document, is a tool known as a “work product matrix” (see Figure 12). The work product matrix will aid in improving program execution and ensure that a given program is ready to proceed to the next phase in the product lifecycle.

Located in Section 14 is the Critical Gated Events Work Product Matrix. This matrix identifies each of the critical gated events across the top of the chart horizontally; and vertically lists the 12 categories within the Mission Assurance Framework (see Mission Assurance Guide Aerospace TOR-2007(8546)-6018 for additional details) – along with a detailed description of each work product element (e.g., Mission Assurance Plan; Worst-Case Analyses; and Detailed Drawings). The work product elements range from program planning documents to key technical analyses to drawings describing many different types of entities. It should be noted that the list of elements is not meant to be all encompassing but represent elements typically found on almost every space vehicle program. Because of the considerable variability in “terminology and phasing” throughout the space industry, this matrix will help standardize the content and description of each element.

Additionally, contained in the matrix at the intersection points of a particular gated event and a work product element, is a corresponding maturity description. This maturity description is abbreviated for a term to describe a level of maturity for the work product at the particular phasing point in the program. There are five levels of maturity described in this matrix: Created, Updated, Baselined, Revised, and Finalized. Each maturity term is defined as follows:

1. Created: The initial generation or first draft of a work product being developed that is under author control and has not been reviewed.
2. Updated: A work product that contains new information, remains under author or integrated product team (IPT) control, and has completed an informal review process by peers.
3. Baselined: A prepared or concluded work product that has been iterated, has IPT or program management acceptance, is ready for a formal gated event review, and may not be changed without formal configuration management (CM) revision control.
4. Revised: A reevaluated work product that has been significantly modified, remains under CM control, and will require approval authority for changes to the technical baseline.
5. Finalized: Brings a work product to its final state where it has been reviewed and/or signed off by the approval authority and is available to be used.

Identifying the level of maturity of a work product at a particular phase in the product lifecycle is useful to help drive expectations of “completeness” required for mission success in the space industry. Basically, the definitions used to describe each term aid in defining who controls a work product; who has reviewed it; and what level of approval is required for the particular work product. The work product matrix can best be used as a checklist, along with the entrance and exit criteria, to understand the maturity and completeness of a program’s work products prior to every critical gated review.

Critical Gated Events Work Products		A	B	1	2	3
		RFP Release	Source Selection	Requirements Review (RR)	Preliminary Design Review (PDR)	Critical Design Review (CDR)
<b>MISSION ASSURANCE</b>						
1	<b>Mission Assurance Plan</b> The Mission Assurance Plan (MAP) represents a complete set of activities that could be performed by the contractor/subcontractors/program, during the entire life cycle of the system(s) to ensure mission success. Mission success means the system(s) will meet specified performance and functional requirements, but also user and operator expectations in terms of end-to-end operational effectiveness, operability, suitability, supportability, and safety.			<b>C, U, B</b>	<b>R</b>	<b>F</b>

Gated Event (points to CDR)  
 MA Framework Categories (points to MISSION ASSURANCE)  
 Work Product Elements (points to 1)  
 Work Product Description (points to Mission Assurance Plan text)  
 Work Product Maturity Level (points to C, U, B)

Figure 12. Work product matrix checklist.

### **3. Gate 1: Requirements Review**

#### **3.1 Introduction**

For the purposes of this report, the activities and objectives typically associated with the SRR, the SDR, and the System Functional Review (SFR) have been combined into the Requirements Review (RR). The RR may be conducted as one review or may be broken into its constituent reviews based on the size, technical complexity, or risk associated with the program. The RR is a multidiscipline product and process assessment focusing on critical system engineering functions.

The RR demonstrates that the proposed system architecture/design, system requirements, and flow-down to all functional elements meet the system mission objectives. It verifies that the system-level requirements/system-level specifications allocation is complete and evaluates the contractor's systems engineering approach and processes for optimization, correlation, completeness, and risk mitigation associated with the system/allocated technical requirements. Additionally, the RR is used to evaluate a contractor's ability to design and build a system within proposed constraints including cost, schedule, and risk tolerance.

The RR should be conducted when a significant portion of the system requirements have been established and baselined. At the time of the RR there should be minimal TBD/TBRs/TBS (or TBXs); any remaining TBXs must have resolution plans that close by PDR.

#### **3.2 Purpose**

The purpose of the RR is to verify that the contractor's design requirements fully satisfy the customer's requirements, to demonstrate project readiness to begin preliminary design, and to obtain an approved technical baseline and place it under change control. To that end, the project shall demonstrate that the baseline mission requirements are clearly understood, system definition is complete, allocation of requirements to each independent system element and its respective subsystems is complete, verifiable, and cross-consistent (i.e., no contradictory requirements have been introduced across interdependent systems), and that lower-level requirements are traceable to the mission level.

In addition to evaluating progress to date, the RR should review critical system engineering processes to include those associated with requirements management, design, development, manufacturing, V&V, test, technical performance measures (TPMs) management, and risk management. Critical to any gated review is identification and management of risk associated with the key products and processes.

#### **3.3 Entrance Criteria**

1. The system architecture/design is developed to one level below the product being reviewed.
2. An initial verification cross-reference matrix (VCRM) defining the flow of requirements from the higher level to lower level has been generated, evaluated, and baselined; verification methods have been determined and preliminary acceptance criteria identified.
3. System requirements are allocated to the next lower level; functional analysis and allocation of requirements to next lower level is complete.
4. System requirements reflect all updates to the technical requirements document (TRD). All approved changes should be reflected in system requirements.
5. Qualification requirements have been identified and are traceable to the preliminary system-level verification plan.

6. The system and its operation are sufficiently understood to warrant design and acquisition of end items.
7. Preliminary schedule, cost, and management baselines have been established that tie to the established functional baseline.
8. Sub-allocations have been reviewed and agreed upon by all relevant stakeholders.
9. Top-level TPMs have been established and a TPM management plan defined.
10. Critical technologies are identified and required technology readiness levels (TRLs) maturation is planned.

### 3.4 Exit Criteria

#### Design description:

- a. Document and manage system design changes made since the proposal.
- b. Document results of requirements trades and include rationale for selected alternatives. Identify ongoing or future trade studies, understand the potential impact of results on the design. Define rationale for trade results.
- c. Create block diagrams to illustrate functional flow and clearly define interfaces with external systems, interfaces between each independent system element (e.g., spacecraft, science instruments, launch vehicle, ground system, etc.), and interfaces within each independent element down to the subsystem level or below.
- d. Create cross-correlation matrix identifying inter-related requirements and certifying their cross-consistency.
- e. Provide results of appropriate system analyses (e.g., performance, error budgets, reliability) illustrating adequacy of system design to accomplish mission objectives within constraints and with acceptable risk.
- f. Ensure mission-critical failure modes have been identified. Define redundancies and/or workarounds – approve single-string design approach.
- g. Ensure technology development-related items continue on track and mitigation plans remain viable.
- h. Determine utilization of heritage elements and complete evaluation for their use on the current mission.
- i. Ensure margins for all critical resources (mass, power, data rate, etc.) meet requirements.
- j. Define and approve usage and control of units of measurement.
- k. Define approach to verification of compatibility across all interfaces.
- l. Ensure agreement on producibility of the proposed design concept has been obtained.

#### Requirements-related processes:

- a. System requirements/system specification/functional baseline is baselined and put under change control.
- b. Processes for the allocation and control of requirements are documented and approved.
- c. The TPM plan is established. The approach for tracking and controlling allocation and reserves of key resources (e.g., mass, power, memory, etc.) is documented and approved.
- d. The System Engineering Management Plan (SEMP) is reviewed. The approach to controlling and integrating all technical activities is defined and documented. Plans for design, production, and verification activities are defined and documented.
- e. The requirements management tool provides two-way traceability.

#### Requirements definition:

- a. System requirements are derived from user documents (e.g., CONOPS, TRD, Analysis of Alternatives (AoA) results, initial capabilities document)
- b. Interface requirements with external systems are defined.
- c. Interface requirements between system elements are defined.
- d. Interface requirements between subsystems and components of each system element are defined.

- e. Functional requirements for subsystems and components of each system element are defined so as to fully achieve system requirements. Such requirements are verifiable and are traceable to their respective system and mission requirements.
- f. TRLs for key technologies are established and maturation plans established.
- g. Mission operations, data acquisition, data processing, and data analysis requirements are fully defined.
- h. Resolution plans are in place for all TBXs that close by PDR.

Requirements verification:

- a. VCRM is adequate for verification. Preliminary approaches for the verification of all requirements have been defined, and preliminary acceptance criteria have been defined at the deliverable end-item level.

Risk management:

- a. A risk management process is documented in a risk management plan and process is utilized.
- b. System and programmatic risk is acceptable based on current point in program lifecycle. All significant risks, problems, and open items are clearly defined and characterized, assessed and tracked (including programmatic, development and flight performance related items).
- c. Risk reduction/mitigation activities planned to complete prior to design phase are complete and results are reflected in a functional and allocated baseline. Mitigation plans in progress are delivering anticipated risk reduction within constraints. Credible triggers for exercising alternatives or contingency plans are defined.
- d. Assessment and handling of all known risks is reviewed. Risks commonly associated with the next phase of the program lifecycle are considered.
- e. Reliability requirements have been factored into design decisions.
- f. Single-point failures are compatible with approved project philosophy and risk tolerance.
- g. Lessons learned have been appropriately researched and adapted.

Safety:

- a. A preliminary safety plan identifies all requirements, planned tailoring approaches, and non-compliances.
- b. Preliminary hazards, controls, and verification methods are identified and documented.
- c. Any open safety issues are identified with plans for resolution that close by PDR.
- d. Preliminary plans and schedules for all required safety submittals are defined.

Assurance activities:

- a. Assurance requirements have been defined (EEE parts and materials usage, reliability analyses, quality control, problem reporting, etc.) and preliminary plans are completed.

Implementation planning:

- a. Program flow has been defined and required quantities of hardware and software items are defined.
- b. Plans for controlling technical activities (systems engineering, software development, verification, configuration control, etc.) have been approved.
- c. Environmental impact assessments and control activities are on track.

### 3.5 Work Products

Within the RR phase, the following work products are defined and stasured as follows in Table 1:

Table 1. Work Product Matrix Detail #1

<b>Critical Gated Events Work Products</b>		<b>1</b>
		<b>Requirements Review (RR)</b>
<b>MISSION ASSURANCE</b>		
1	Mission Assurance Plan	<b>C, U, B</b>
2	Risk Management Plan (RMP)	<b>C, U, B</b>
3	Program Management Plan (PMP)	<b>C, U, B</b>
<b>REQUIREMENTS, ANALYSIS &amp; VALIDATION</b>		
1	Concept of Operations (CONOPS) Plan	<b>C, U, B</b>
2	System Architecture (Block Diagrams & Functional Flow Diagrams)	<b>C, U, B</b>
3	A-Specification for System Functional Baseline	<b>C, U, B</b>
4	B-Specifications for Development	<b>C, U</b>
5	C-Specifications for Configured Items (Units/Components/Processes)	
6	Verification Cross-Reference Matrix (VCRM)	<b>C, U, B</b>
7	Technical Performance Measure (TPM) Plan	<b>C, U, B</b>
8	Interface Control Documents (Intra-ICDs) [Units/Subsystems/GSE]	<b>C, U</b>
9	Spacecraft to Payload ICD (Internal)	<b>C, U</b>
10	Spacecraft to Launch Vehicle ICD (External)	<b>C, U</b>
11	Spacecraft to Ground Station ICD (External)	<b>C, U</b>
12	Systems Engineering Management Plan (SEMP)	<b>C</b>
13	Requirements Verification Plan (RVP) [V&V Plan, VCRM]	<b>C</b>
14	Interface Verification Plan (IVP)	<b>C</b>
15	Analysis & Simulation Plan (ASP)	<b>C</b>
16	Algorithm Development Plan (ADP)	<b>C</b>
17	Error Budgets & Allocation Analysis	<b>C, U</b>
18	Post Delivery Support Plan (PDSP)	<b>C</b>
19	Technology Insertion Plan (TIP)	<b>C</b>
20	Analysis Verification Reports	
21	Inspection Verification Reports	
22	Demonstration Verification Reports	
<b>RELIABILITY ENGINEERING</b>		
1	Reliability, Availability, Maintainability Plan (RAMP)	<b>C</b>
2	Reliability Analyses (Failure Prediction, FMEA, FMECA, SPF, etc.)	<b>C</b>
3	Critical Items List & Limited Life List	<b>C</b>
4	FRACAS/FRB Plan	



<b>Critical Gated Events Work Products</b>	<b>1</b>
	<b>Requirements Review (RR)</b>
<b><i>PARTS, MATERIALS &amp; PROCESSES (PMP) ENGINEERING</i></b>	
1 Parts, Material & Process (PMP) Plan	<b>C, U</b>
2 Approved Parts, Materials & Processes List (APMPL)	<b>C, U</b>
3 Major Subcontracts Plan (MSP or SCM Plan)	<b>C, U</b>
4 Contamination Control Plan (CCP)	<b>C, U</b>
<b><i>CONFIGURATION MANAGEMENT</i></b>	
1 Configuration Management Plan (CMP)	<b>C, U</b>
2 Data Management Plan (DMP)	<b>C, U</b>
<b><i>QUALITY ASSURANCE</i></b>	
1 Product Assurance Plan	<b>C</b>
<b><i>SYSTEM SAFETY ASSURANCE</i></b>	
1 SSHP (System Safety & Hazard Plan) [includes Human Factors]	<b>C</b>
2 Environmental Effects Plan (EEP) [EMI/EMC Plan, Radiation Effects, etc.]	<b>C</b>
3 Electro Static Discharge Plan (ESDP) [includes Spacecraft Charging, Power Distribution & Grounding]	<b>C</b>
<b><i>DESIGN ASSURANCE</i></b>	
1 Hardware Development Plan (HDP)	<b>C</b>
2 Detail Drawings	<b>C</b>
3 Assembly Drawings	
4 Installation Drawings/Procedures	
5 Schematics/Wiring Diagrams	
6 Worst-Case Design Analyses	<b>C</b>
7 Structural, Thermal, Optical, Performance (STOP) Analyses	<b>C</b>
8 Packaging, Handling, Storage & Transportation (PHST) Plan	
<b><i>SOFTWARE ASSURANCE</i></b>	
1 Software Development Plan (SDP)	<b>C</b>
2 Software Requirements Specification	<b>C, U</b>
3 Software Manuals	
<b><i>MANUFACTURING ASSURANCE</i></b>	
1 Manufacturing Operating Plan (MOP)	<b>C</b>
2 Producibility Plan	<b>C, U</b>
3 Production Plan & Master Production Schedule (Capacity & Throughput Analysis)	<b>C</b>
4 Build History Planning/Work Orders	<b>C</b>
5 Kitting & Parts Status Plan	<b>C</b>

<b>Critical Gated Events Work Products</b>	<b>1</b>
	<b>Requirements Review (RR)</b>
6 Facilities/Space Plan (FSP) 7 Manufacturing Facility Certification 8 Skills Training & Certification Matrix 9 GSE/STE/Tooling Certified/Calibrated/Proof-Loaded/PM Matrix	<b>C</b>
<b>INTEGRATION, TEST &amp; EVALUATION</b>	
1 Test Requirements Specification (TRS)	<b>C</b>
2 Environmental Test Requirements Specification (ETRS)	<b>C</b>
3 GSE/STE ICD (Mech/Elect/Optical/Thermal)	<b>C, U</b>
4 Embedded Test (BIT)/Integrated Diagnostics/DFT Requirements	<b>C</b>
5 GSE/STE Analysis, FMEA	
6 GSE/STE Metrology Plan	
7 Test & Evaluation Master Plan (TEMP) [includes Design-for-Test; BIT Testing]	<b>C</b>
8 Top-Level Test Configuration Drawing	
9 Thermal Vacuum Test Plan	<b>C</b>
10 EMI/EMC Test Plan	<b>C</b>
11 Vibration, Shock & Acoustics Test Plan	<b>C</b>
12 Mass Properties Test Plan	<b>C</b>
13 Test Scripts/Recipes	
14 Test Procedures – Electrical (Functional)	
15 Test Procedures – RF	
16 Test Procedures – Optical	
17 Test Procedures – Thermal Vacuum	
18 Test Procedures – Thermal Balance	
19 Test Procedures – Vibration/Shock	
20 Test Procedures – Acoustic	
21 Test Procedures – Mass Properties	
22 Test Lab Certification	
23 Test Verification Reports	
24 User Guides/Test Manuals	
<b>OPERATIONAL READINESS ASSURANCE</b>	
1 Pre-Launch DD-250	
2 Flight Worthiness Certification by Launch Authority	
3 Aerospace Launch Verification Letter	
4 Early On-Orbit Testing (EOT) Report	
5 SCA Change Notice	

**C = Created:** The initial generation or first draft of a work product being developed that is under author control and has not been reviewed.

**U = Updated:** A work product that contains new information, remains under author or IPT control, and has completed an informal review process by peers.

**B = Baselined:** A prepared or concluded work product that has been iterated, has IPT or program management acceptance, is ready for a formal gated event review, and may not be changed without formal CM revision control.

**R = Revised:** A reevaluated work product that has been significantly modified, remains under CM control, and will require approval authority for changes to the technical baseline.

**F = Finalized:** Brings a work product to its final state where it has been reviewed and/or signed off by the approval authority and is available for use.

### 3.6 References

- MIL- STD-1521B *Technical Reviews and Audits for Systems, Equipments and Computer Software,*  
Department of Defense – USAF,  
4 June 1985
- NSS-03-01 *National Security Space Acquisition Policy,*  
Department of Defense – USAF,  
27 December 2004
- Aerospace TOR-2006(8506)-4494 *Space Vehicle Systems Engineering Handbook,*  
Edited by W. Englehart,  
30 November 2005
- INCOSE-TP-2003-0126-02, Version 2a *Systems Engineering Handbook,*  
International Council on Systems Engineering  
(INCOSE), Technical Staff;  
1 June 2004
- Defense Acquisition University *DAU Systems Engineering Fundamentals,*  
Defense Acquisition University Press,  
1 January 2001
- NASA GSFC-STD-1001 *Criteria for Flight Project Critical Milestone Reviews,*  
Approved by R. Day,  
19 February 2005
- NASA SP-6105 *NASA Systems Engineering Handbook,*  
R. Shishko, Ph.D.,  
1 June 1995



## 4. Gate 2: Preliminary Design Review (PDR)

### 4.1 Introduction

The PDR evaluates the contractor's technical adequacy, progress, and risk resolution for the selected design-to approach for all CIs, and establishes a CI design baseline down to the assembly level. The PDR demonstrates design compatibility with the performance and engineering specialty requirements of the hardware development specifications. Included is an evaluation of technical risks associated with the manufacturing process/methods and the establishment of the compatibility of the physical and functional interfaces among and between CIs (e.g., units, subsystems, or system), facilities, CSCIs, and personnel. The PDR processes allow for an engineering assessment of the technical adequacy of top-level design, testing approach, and CONOPS. PDRs are normally conducted once per program for each CI at the assembly level, subsystem, element, and segment, building to the system level as appropriate.

### 4.2 Purpose

The purpose of the PDR is to demonstrate project readiness to proceed with the detailed design and to complete the flight and ground system development and mission operations in order to meet mission performance requirements within the identified cost and schedule constraints. To that end, the project demonstrates that the preliminary design meets all system requirements with acceptable risk. It shows that the correct design option has been selected, resource allocations have been made, interfaces have been identified, and verification methods have been identified. Supportive design analyses confirm compliance with requirements.

### 4.3 Entrance Criteria

1. Actions from the previous gate have been satisfactorily addressed.
2. TPMs are updated.
3. Program management and the customer agree upon the PDR agenda.
4. The system-level (i.e., the system at the level of the PDR) specification is complete and free of TBXs.
5. Heritage qualification data is available for any proposed reuse hardware and software.
6. All work products required during the preliminary design phase are completed to the required maturity (see work products below).

### 4.4 Exit Criteria

1. Systems engineering/architecture development
  - a. The system-, segment-, subsystem-, and component-allocated requirements are complete, feasible, verifiable, and clearly stated.
  - b. System requirements functional decomposition is completed.
  - c. An allocated baseline established based on and traceable to the approved mission and system functional baselines.
  - d. System integration and verification functional performance requirements are allocated to all segments, subsystems, and components.
  - e. System/segment/subsystem and component-level interfaces are baselined.
  - f. Allocated decomposition is completed for each hardware configuration item (HWCI) and CSCI.
  - g. System performance (design) specification is traceable to the allocation baseline.
  - h. System/segment/subsystem and component verification and validation approaches are developed for the preliminary design.

- i. System and next level-lower specifications compatible with program CONOPS.
2. Design description (including requirements, evolution, and heritage):
  - a. A complete and comprehensive definition of the entire design exists to the component level.
  - b. Results of trade studies and rationale for selected alternatives are defined.
  - c. Remaining trade studies are identified and potential impacts are understood.
  - d. Requirements flowdown and traceability to the appropriate subsystem of each system element, (and to the extent practical, to the component), has been completed. A preliminary verification matrix has been defined that includes the selected verification method for each requirement, including the compatibility of units of measurement, where applicable.
  - e. Requirements and design changes since the previous gate and their rationale are documented.
  - f. Appropriate descopes have been identified:
    - Plans and trigger points have been identified
    - Impact to mission objectives and deliverables has been defined
    - Potential impacts to mass, power, software and other resources have been quantified
    - Budget and schedule impacts have been estimated
  - g. Long lead items and their acquisition plans have been identified. Any fabrication needed prior to CDR has been identified.
  - h. Proof of heritage applicability (similarity) has been assessed. Required analyses and/or tests of heritage designs to address all design modifications, changes in the expected environment and operational differences have been identified.
  - i. EEE parts considerations:
    - Parts stress analysis (PSA) requirements have been defined.
    - Radiation tolerance requirements have been defined.
    - Selection, de-rating, screening and qualification test criteria are defined.
    - Preliminary parts lists are complete.
    - Long lead acquisitions are planned. Risk mitigations are defined.
  - j. Software considerations:
    - Preliminary requirements are identified, including language, structure, logic flow, CPU throughput and memory loading, re-use, safety, and security
    - Nominal operating scenarios are identified, along with fault detection, isolation, and recovery strategies
    - Design and development plans are defined including lines of code estimates, number of builds, tools, and procedures
    - Verification strategies are defined including test environments
    - Preliminary system performance estimates exist
    - Independent verification and validation (IV&V) plans are identified.
3. Total System Performance (budgets/projections/margins for combined optical, thermal, mechanical, control, etc.):
  - a. Budgets and margins for system performance (pointing, throughput, etc.) are defined.
  - b. Preliminary system performance estimates are complete.
  - c. Estimates of critical resource margins (e.g., mass, power, delta V, CPU throughput and memory, etc.) have been delineated based on design maturity.
    - Sufficient margin exists based on applicable standards; risk mitigation strategies are defined for margins below guidelines
  - d. Preliminary analyses are completed for:
    - Mechanical loads, stress, fracture control, and torque margins
    - Thermal environment, including predicted performance and margins
    - Radiation protection requirements and design margins
    - Expected lifetime and margins for limited life items

4. Design analyses:
  - a. Preliminary analyses critical to proof of design are complete.
  - b. Analyses required to enable detailed design should be complete.
  - c. Rationale and risk assessment exists for outstanding analyses that may, at completion, impact the design baseline, e.g., mass, power, volume, interfaces.
  - d. Status and schedule of final analyses are defined.
5. Development test activities:
  - a. Breadboard and engineering model development activities have been defined.
  - b. Test objectives and criteria have been identified.
  - c. Completed breadboard and engineering model test results have been iterated into the design.
  - d. Required life tests have been identified and are planned for completion by CDR.
6. Risk management:
  - a. A risk management process that meets requirements is defined and utilized.
  - b. All significant risks, problems, and open items are identified and tracked (including programmatic, development, and flight performance-related items). Risk mitigation plans are appropriate and credible.
  - c. Lessons learned have been appropriately researched and adapted.
  - d. Initial reliability analyses are completed and results have been factored into the design.
  - e. Analyses include:
    - Probabilistic risk assessment (PRA), as appropriate, including Event Tree/Fault Tree system and scenario analysis
    - Failure Mode and Effects Analysis (FMEA)
    - Singlepoint failure (SPF) assessment and retention rationale
    - Reliability driver (weak design links) assessment
    - Worst-case analysis (WCA)
  - f. Risks associated with the reuse of heritage hardware and software are presented and understood.
7. Safety:
  - a. An approved safety plan identifies all requirements as well as any planned tailoring approaches or intended non-compliances.
  - b. Preliminary hazards, controls, and verification methods are identified and documented.
  - c. Any open safety issues are identified with plans for resolution.
  - d. Plans and schedules for all required safety submittals are defined and documented.
8. Assurance activities:
  - a. Quality Assurance plans are complete, including the problem reporting system.
  - b. Preliminary production planning and process controls (including strategy for control/verification of units of measurement) have been identified. Applicable workmanship standards have been defined.
  - c. Special materials considerations have been identified.
9. Implementation plans:
  - a. Equipment and facilities for the development and test of hardware and software have been identified.
  - b. Preliminary planning for systems integration and test activities, including validation and calibration, as well as operations compatibility testing, has been defined. Facilities are available and, if needed, utilization agreements are in work.
  - c. Risks associated with integration & test (I&T) have been characterized and preliminary mitigations have been defined.
  - d. Contamination requirements and preliminary control plans are defined.
10. ICDs:
  - a. Preliminary ICDs, with external systems as well as between system elements, are complete.

- b. Items marked “to be determined” (TBD) are clearly identified. Plans and schedules exist for their definition.
  - c. Requirements on all functional and physical interfaces are understood and capture any interfaces noted in block diagrams, and baseline ICDs are complete and agree with lower-level specifications.
11. Qualification/environmental test plans and test flow:
- a. Approach to qualification/proto-flight/acceptance testing has been defined.
  - b. Environmental verification flow is traceable from component to system level.
  - c. Interweaving of environmental and functional test flow has been defined.
  - d. Preliminary identification of all mechanical and electrical GSE has been completed.
  - e. Special test requirements have been defined.
  - f. Test facilities have been defined. Facilities are available and, if needed, utilization agreements are in work.
12. Logistics:
- a. Transportation methods are identified including environmental control and monitoring considerations.
  - b. Preliminary identification of all GSE has been completed.
  - c. Transportation container requirements have been identified.
13. Launch vehicle interfaces:
- a. Preliminary ICD is complete. Items marked TBD are clearly identified. Plans and schedules exist for their definition.
  - b. Payload-driven first flight/mission unique items have been identified and mission implications are understood.
  - c. Potential launch vehicle related risk items are identified.
  - d. Preliminary vehicle orbital debris assessment has been completed.
  - e. Preliminary integrated payload/launch vehicle activity flow has been defined.
  - f. Preliminary schedule of all vehicle/payload inter-related activities has been defined.
  - g. Preliminary coupled loads analysis has been initiated.
14. Ground operations, mission operations, end-of-life:
- a. Mission operations concepts are defined.
  - b. Launch site and mission operations unique ground systems have been defined.
  - c. Preliminary plans are defined for launch site activities, launch and early orbit operations.
  - d. Preliminary planning for involvement and training of launch site and of mission operations teams are defined.
  - e. Preliminary Orbital Debris Assessment is complete. Potential trades have been determined. End-of-life requirements and design accommodations are understood.
15. Lessons learned have been researched and appropriately adapted. New lessons learned have been documented.

#### **4.5 Work Products**

Within the PDR phase, the following work products are defined and stasured as follows in Table 2:



Table 2. Work Product Matrix Detail #2

<b>Critical Gated Events Work Products</b>		<b>2</b>
		<b>Preliminary Design Review (PDR)</b>
<b>MISSION ASSURANCE</b>		
1	Mission Assurance Plan	<b>R</b>
2	Risk Management Plan (RMP)	<b>R</b>
3	Program Management Plan (PMP)	<b>R</b>
<b>REQUIREMENTS, ANALYSIS &amp; VALIDATION</b>		
1	Concept of Operations (CONOPS) Plan	<b>R</b>
2	System Architecture (Block Diagrams & Functional Flow Diagrams)	<b>R</b>
3	A-Specification for System Functional Baseline	<b>R</b>
4	B-Specifications for Development	<b>B</b>
5	C-Specifications for Configured Items (Units/Components/Processes)	<b>C, U</b>
6	Verification Cross-Reference Matrix (VCRM)	<b>R</b>
7	Technical Performance Measure (TPM) Plan	<b>R</b>
8	Interface Control Documents (Intra-ICDs) [Units/Subsystems/GSE]	<b>B</b>
9	Spacecraft to Payload ICD (Internal)	<b>B</b>
10	Spacecraft to Launch Vehicle ICD (External)	<b>B</b>
11	Spacecraft to Ground Station ICD (External)	<b>B</b>
12	Systems Engineering Management Plan (SEMP)	<b>U</b>
13	Requirements Verification Plan (RVP) [V&V Plan, VCRM]	<b>U</b>
14	Interface Verification Plan (IVP)	<b>U</b>
15	Analysis & Simulation Plan (ASP)	<b>U</b>
16	Algorithm Development Plan (ADP)	<b>U</b>
17	Error Budgets & Allocation Analysis	<b>B</b>
18	Post Delivery Support Plan (PDSP)	<b>U</b>
19	Technology Insertion Plan (TIP)	<b>U</b>
20	Analysis Verification Reports	
21	Inspection Verification Reports	
22	Demonstration Verification Reports	
<b>RELIABILITY ENGINEERING</b>		
1	Reliability, Availability, Maintainability Plan (RAMP)	<b>U</b>
2	Reliability Analyses (Failure Prediction, FMEA, FMECA, SPF, etc.)	<b>U</b>
3	Critical Items List & Limited Life List	<b>U</b>
4	FRACAS/FRB Plan	

<b>Critical Gated Events Work Products</b>		<b>2</b>
		<b>Preliminary Design Review (PDR)</b>
<b><i>PARTS, MATERIALS &amp; PROCESSES (PMP) ENGINEERING</i></b>		
1	Parts, Material & Process (PMP) Plan	<b>B</b>
2	Approved Parts, Materials & Processes List (APMPL)	<b>B</b>
3	Major Subcontracts Plan (MSP or SCM Plan)	<b>B</b>
4	Contamination Control Plan (CCP)	<b>U</b>
<b><i>CONFIGURATION MANAGEMENT</i></b>		
1	Configuration Management Plan (CMP)	<b>B</b>
2	Data Management Plan (DMP)	<b>B</b>
<b><i>QUALITY ASSURANCE</i></b>		
1	Product Assurance Plan	<b>U</b>
<b><i>SYSTEM SAFETY ASSURANCE</i></b>		
1	SSHP (System Safety & Hazard Plan) [includes Human Factors]	<b>U</b>
2	Environmental Effects Plan (EEP) [EMI/EMC Plan, Radiation Effects, etc.]	<b>U</b>
3	Electro Static Discharge Plan (ESDP) [includes Spacecraft Charging, Power Distribution & Grounding]	<b>U</b>
<b><i>DESIGN ASSURANCE</i></b>		
1	Hardware Development Plan (HDP)	<b>U</b>
2	Detail Drawings	<b>U</b>
3	Assembly Drawings	<b>C</b>
4	Installation Drawings/Procedures	<b>C</b>
5	Schematics/Wiring Diagrams	<b>C</b>
6	Worst-Case Design Analyses	<b>U</b>
7	Structural, Thermal, Optical, Performance (STOP) Analyses	<b>U</b>
8	Packaging, Handling, Storage & Transportation (PHST) Plan	<b>C</b>
<b><i>SOFTWARE ASSURANCE</i></b>		
1	Software Development Plan (SDP)	<b>U</b>
2	Software Requirements Specification	<b>B</b>
3	Software Manuals	<b>C</b>

<b>Critical Gated Events Work Products</b>		<b>2</b>
		<b>Preliminary Design Review (PDR)</b>
<b>MANUFACTURING ASSURANCE</b>		
1	Manufacturing Operating Plan (MOP)	<b>U</b>
2	Producibility Plan	<b>B</b>
3	Production Plan & Master Production Schedule (Capacity & Throughput Analysis)	<b>U</b>
4	Build History Planning/Work Orders	<b>U</b>
5	Kitting & Parts Status Plan	<b>U</b>
6	Facilities/Space Plan (FSP)	<b>U</b>
7	Manufacturing Facility Certification	<b>C, U</b>
8	Skills Training & Certification Matrix	
9	GSE/STE/Tooling Certified/Calibrated/Proof-Loaded/PM Matrix	
<b>INTEGRATION, TEST &amp; EVALUATION</b>		
1	Test Requirements Specification (TRS)	<b>U</b>
2	Environmental Test Requirements Specification (ETRS)	<b>U</b>
3	GSE/STE ICD (Mech/Elect/Optical/Thermal)	<b>B</b>
4	Embedded Test (BIT)/Integrated Diagnostics/ DFT Requirements	<b>U</b>
5	GSE/STE Analysis, FMEA	<b>C</b>
6	GSE/STE Metrology Plan	<b>C</b>
7	Test & Evaluation Master Plan (TEMP) [includes Design-for-Test; BIT Testing]	<b>U</b>
8	Top-Level Test Configuration Drawing	<b>C</b>
9	Thermal Vacuum Test Plan	<b>U</b>
10	EMI/EMC Test Plan	<b>U</b>
11	Vibration, Shock & Acoustics Test Plan	<b>U</b>
12	Mass Properties Test Plan	<b>U</b>
13	Test Scripts/Recipes	<b>C</b>
14	Test Procedures – Electrical (Functional)	<b>C</b>
15	Test Procedures – RF	<b>C</b>
16	Test Procedures – Optical	<b>C</b>
17	Test Procedures – Thermal Vacuum	<b>C</b>
18	Test Procedures – Thermal Balance	<b>C</b>
19	Test Procedures – Vibration/Shock	<b>C</b>
20	Test Procedures – Acoustic	<b>C</b>
21	Test Procedures – Mass Properties	<b>C</b>
22	Test Lab Certification	<b>C</b>
23	Test Verification Reports	
24	User Guides/Test Manuals	

<b>Critical Gated Events Work Products</b>		<b>2</b>
		<b>Preliminary Design Review (PDR)</b>
<b>OPERATIONAL READINESS ASSURANCE</b>		
1	Pre-Launch DD-250	
2	Flight Worthiness Certification by Launch Authority	
3	Aerospace Launch Verification Letter	
4	Early On-Orbit Testing (EOT) Report	
5	SCA Change Notice	

**C = Created:** The initial generation or first draft of a work product being developed that is under author control and has not been reviewed.

**U = Updated:** A work product that contains new information, remains under author or IPT control, and has completed an informal review process by peers.

**B = Baseline:** A prepared or concluded work product that has been iterated, has IPT or program management acceptance, is ready for a formal gated event review, and may not be changed without formal CM revision control.

**R = Revised:** A reevaluated work product that has been significantly modified, remains under CM control, and will require approval authority for changes to the technical baseline.

**F = Finalized:** Brings a work product to its final state where it has been reviewed and/or signed off by the approval authority and is available for use.

#### 4.6 References

MIL- STD-1521B

*Technical Reviews and Audits for Systems, Equipments, and Computer Software,*  
Department of Defense – USAF,  
4 June 1985

NSS-03-01

*National Security Space Acquisition Policy,*  
Department of Defense – USAF,  
27 December 2004

Aerospace TOR-2006(8506)-4494

*Space Vehicle Systems Engineering Handbook,*  
Edited by W. Englehart,  
30 November 2005

TOR-2007(8583)-6414 (Draft)

*Technical Reviews and Audits for Systems, Equipments, and Computer Software,*  
Department of Defense – USAF and  
L. Peresztegy, C. O'Connor,  
12 July 2007

INCOSE-TP-2003-0126-02, Version 2a

*Systems Engineering Handbook,*  
International Council on Systems Engineering (INCOSE),  
Technical Staff,  
1 June 2004

Defense Acquisition University

*DAU Systems Engineering Fundamentals*,  
Defense Acquisition University Press,  
1 January 2001

NASA GSFC-STD-1001

*Criteria for Flight Project Critical Milestone  
Reviews*,  
Approved by R. Day,  
19 February 2005

NASA SP-6105

*NASA Systems Engineering Handbook*,  
R. Shishko, Ph.D.,  
1 June 1995



## 5. Gate 3: Critical Design Review (CDR)

### 5.1 Introduction

The CDR is a multi-disciplined product and process assessment to determine whether the system design is sufficiently mature to proceed to build approval and full-scale manufacturing. It is a critical, co-operative examination of the design solution, its details and its suitability for production and use. The CDR shall be conducted for each CI when detail design is essentially complete.

A series of CDRs are normally held in Systems Development and Demonstration phase for new developments. A CDR is held for each CI and aggregation of CIs in the specification tree. A system CDR is held after completion of all CI or aggregation of CI CDRs. Even when the government elects not to bring the allocated baseline under configuration control by the time of this review, an assessment of the flowdown of requirements from the functional baseline to the lowest level CI for each item in the specification tree should be included in the review. Any changes in the performing activity's draft allocated configuration documentation since the PDR are reviewed by the tasking activity and their impact on the functional baseline is assessed and validated.

This review assesses the system final design as captured in product specifications for each CI in the system (product baseline), and ensures that each product in the product baseline has been captured in the detailed design documentation. Product specifications for hardware enable the fabrication of CIs, and may include production drawings. Product specifications for software (e.g., software design documents) enable coding of a CSCI.

The CDR should include a review of the test design for the prime flight hardware, focused on the architecture and design of the (non-flight hardware) test equipment, as well as the test processes.

The program manager should conduct the CDR when the "build-to" baseline has been achieved, allowing production and coding of software deliverables to proceed. A rule of thumb is that 75% to 90% of (manufacturing quality) product drawings and associated instructions should be complete, and that 100% of all flight worthiness critical component (critical safety items and critical application items) drawings are complete. The CDR is typically conducted as the final technical review of the selected design approach for a CI or for a functionally related group of CIs. For complex/large CIs the CDR may be conducted on an incremental basis, i.e., progressive reviews are conducted versus a single CDR.

The CDR should be conducted prior to fabrication/production/coding release, to assess that:

- The detailed design solutions, as reflected in the Hardware Product Specification, software detailed design document (SDDD), database design document(s) (DBDD(s)), Interface Design Documents (IDDs), and engineering drawings satisfy requirements established by the system specification.
- The overall design and manufacturing risks associated with each CI are manageable within program cost and schedule.
- All technologies have advanced to TRL 6 as a minimum.

### 5.2 Purpose

A successful CDR demonstrates that the detailed design/system product baseline/"build to" baseline/system specification for each CI (e.g., CSCIs, units, subsystems, or system) including internal and external interfaces, meet all requirements (functional, performance, and engineering specialty) with

acceptable margin and risk. It demonstrates that the production baseline/“build to” documentation/system design documentation (product baseline, including item detail specifications, material specifications, and process specifications) is satisfactory to start initial fabrication/manufacturing, integration, and verification of hardware and software. The approved detailed design serves as the basis for final production planning and initiates the development of final software code. Design compatibility with external interfaces have been established. It includes a series of reviews conducted for each hardware CI before release of design to fabrication, and each CSCI before final coding and testing.

### 5.3 Entrance Criteria

1. All lower-level CI CDRs have been completed and major issues are closed or have documented corrective action plans.
2. Parts drawings, schematics, and wire lists are complete and under configuration control. Releases of assembly drawings are compliant with material requirements planning (MRP) needs.
3. All Make-Buy/Make-Where decisions are complete.
4. The product’s physical architecture and integrated detailed design are defined and satisfies requirements, including interoperability and interfaces, with adequate margin.
5. An ICD detailing all internal and external interfaces for the product is completed and approved.
6. All work products required during the Critical Design phase are completed to the required maturity (see Section 5.5).

### 5.4 Exit Criteria

1. Design description (including requirements, evolution and heritage):
  - a. A complete and comprehensive definition of the entire design exists, down to the piece-part level.
  - b. Trade studies and rationale for selected alternatives are complete. Impacts of trade decisions have been fully integrated into systems requirements, design, verification, operations, etc.
  - c. Requirements flowdown and traceability have been completed. A verification matrix exists that will incorporate a reference to documented results for each requirement, including the compatibility of units of measurement, where applicable.
  - d. Requirements and design changes since PDR and attendant rationale are documented.
    - A cross-correlation matrix identifying and verifying the cross-consistency of interdependent requirements has been created and validated.
  - e. Potential de-scopes have been identified:
    - Plans and trigger points have been identified
    - Impact to science objectives and deliverables has been defined
    - Impacts to mass, power, software, and other resources have been quantified
    - Budget and schedule impacts have been determined
  - f. Verification of heritage applicability (similarity) has been completed. Results of analyses and tests of heritage designs have addressed all design modifications, and changes in the expected environment and operational differences have been documented. Deficiencies have been corrected.
  - g. A high percentage of drawings (> 80%) are completed:
    - Number and title of all drawings have been identified
    - Status and schedule of drawing completion (e.g., draft/preliminary/under review/final) have been defined
    - Rationale for outstanding drawings is defined and impact is understood



- h. EEE parts considerations:
    - Radiation tolerance requirements have been defined
    - Selection, de-rating criteria, screening, and qualification test criteria are defined
    - Parts lists are complete; waivers to requirements are approved
    - Parts stress analysis is complete; non-conformances have been acceptably resolved
    - Acquisitions and risk mitigations are on-track
  - i. Software considerations:
    - Requirements changes since PDR are identified, including those to language, structure, logic flow, central processing unit (CPU) throughput and memory loading, re-use, safety, and security
    - Current operating scenarios are identified, along with fault detection, isolation, and recovery strategies
    - Current software performance estimates exist, results meet requirements
    - The software requirements specification is approved; the document includes verification matrix mapping requirements to subsystems or CSCIs
    - The software management plan (SMP) is approved and includes lines of code estimate, number of builds, tools, and procedures to be utilized, and the verification strategy (including planned test environments)
    - IV&V plans are approved, activities are on-track, and results to date have been considered
2. Total system performance (budgets/projections/margins for combined optical, thermal, mechanical, control, etc.):
    - a. Budgets and margins for system-level performance (pointing, throughput, etc.) are fully defined.
    - b. System performance estimates are complete. Margins are adequate or viable corrective actions are in work.
    - c. Current estimates of critical resource margins (e.g., mass, power, delta V, CPU throughput and memory, etc.) are regularly updated based on design maturity.
    - d. Sufficient margin exists based on applicable standards. Viable corrective actions are defined for margins below guidelines.
    - e. Analyses are completed for:
      - Mechanical loads, stress, fracture control, and torque margins
      - Thermal environment, including predicted performance and margins
      - Radiation protection requirements and design margins
      - Expected lifetime and margins for limited life items
  3. Design analyses:
    - a. All analyses critical to proof of design are complete.
    - b. Additional outstanding analyses have acceptable completion dates and potential impacts are understood and can be reasonably accommodated.
    - c. Schedules for required updates of analyses are defined.
    - d. Analyses for non-flight test hardware (special test equipment (STE), GSE, tooling)
  4. Development test activities:
    - a. Breadboard and engineering model development activities have been completed. Results are understood and have been iterated into the final design.
    - b. Viable rationale exists for any outstanding testing which may at completion impact the design baseline (e.g., mass, power, volume, interfaces, etc.).
    - c. All required life testing is complete. Where necessary, the design has been modified to accommodate results.
    - d. Potential impact of other outstanding activity is understood and can be reasonably accommodated.

5. Risk management:
  - a. A risk management process that meets requirements is defined and utilized.
  - b. All significant risks, problems, and open items are defined, characterized, assessed, and tracked (including programmatic, development and flight performance related items). Risk control plans are credible and will retire risks in a timely fashion. All risks not addressed by control plans are well understood and accepted.
  - c. Lessons learned have been appropriately researched and adapted.
  - d. Reliability analyses have been updated with appropriate results factored into the design. Analyses include:
    - PRA, as appropriate, including ET/FT system and mission scenarios analysis
    - FMEA
    - SPF assessment and retention rationale
    - Reliability driver (weak design links) assessment
    - WCA
6. Safety:
  - a. An approved, up-to-date safety plan identifies all requirements as well as any planned tailoring approaches or intended non-compliances.
  - b. Analysis of system hazards, identification of control methods, and definition of verification methods is complete. Documentation has been approved.
  - c. Verification of hazard controls is on-track.
  - d. A preliminary safety data package has been submitted to launch range. Timely updates are scheduled.
  - e. Hazardous integration and test procedures and appropriate controls have been identified.
7. Assurance activities:
  - a. Quality Assurance plans are complete, including the problem reporting system.
  - b. Preliminary production planning and process controls (including strategy for control/verification of units of measurement) have been identified. Applicable workmanship standards have been defined.
  - c. Special materials usages have been approved.
8. Implementation plans:
  - a. Equipment and facilities for the development and test of hardware and software have been identified. Design for mission-unique items has been completed.
  - b. Planning for systems integration and test activities, including validation and calibration, as well as operations compatibility testing, is defined. Facilities are available. Needed utilization agreements are complete.
  - c. Risks associated with I&T have been characterized and mitigations are on track for timely closure.
  - d. Contamination requirements and control plans are defined. Required implementation activities are complete.
9. ICDs:
  - a. Up-to-date ICDs, with external systems as well as between system elements, are approved. No TBDs exist.
10. Qualification/environmental test plans and test flow:
  - a. Qualification/proto-flight/acceptance test plans are complete.
  - b. Environmental verification flow is traceable from component to system level.
  - c. Appropriate interleaving of environmental and functional test has been planned.
  - d. Design of all mechanical and electrical GSE has been completed.
  - e. Special test requirements have been fully defined. Compliance activities are on track.
  - f. Test facilities have been defined. Facilities are available and, if needed, utilization agreements are complete.

11. A detailed production plan is in place, showing capacity and factory throughput analysis.
12. An integrated manufacturing schedule (master production schedule) has been exploded to the lowest part level and validated against the production plan for adequate capacity and throughput to determine if production requirements can be met.
13. Logistics:
  - a. Transportation considerations have been fully defined, including environmental control and monitoring requirements.
  - b. Preliminary design of all GSE has been completed.
  - c. Preliminary transportation container design has been completed.
14. Launch vehicle interfaces:
  - a. ICD is complete.
  - b. First flight/mission-unique items have been identified and mission implications are understood.
  - c. Launch vehicle related risk items are identified. Appropriate mitigations are on-track for timely completion.
  - d. Vehicle orbital debris assessment has been approved.
  - e. Integrated payload/launch vehicle activity flow has been defined.
  - f. Schedule of all vehicle/payload inter-related activities has been defined.
  - g. Coupled loads analysis has been completed.
15. For ground operations, mission operations, and end-of-life:
  - a. Science and mission operations concepts are fully defined.
  - b. Design of launch site and mission operations-unique ground systems is complete.
  - c. Plans are defined for launch site activities and early orbit operations.
  - d. Planning for involvement and training of launch site and of mission operations teams are defined.
  - e. Orbital debris assessment is approved. End-of-life requirements and plans are defined.

## 5.5 Work Products

Within the CDR phase, the following work products are defined and stasured as follows in Table 3:

Table 3. Work Product Matrix Detail #3

<b>Critical Gated Events Work Products</b>		<b>3</b>
		<b>Critical Design Review (CDR)</b>
<b><i>MISSION ASSURANCE</i></b>		
1	Mission Assurance Plan	<b>F</b>
2	Risk Management Plan (RMP)	<b>R</b>
3	Program Management Plan (PMP)	<b>R</b>
<b><i>REQUIREMENTS, ANALYSIS &amp; VALIDATION</i></b>		
1	Concept of Operations (CONOPS) Plan	<b>F</b>
2	System Architecture (Block Diagrams & Functional Flow Diagrams)	<b>F</b>
3	A-Specification for System Functional Baseline	<b>F</b>
4	B-Specifications for Development	<b>R</b>

<b>Critical Gated Events Work Products</b>		<b>3</b>
		<b>Critical Design Review (CDR)</b>
5	C-Specifications for Configured Items (Units/Components/Processes)	<b>B</b>
6	Verification Cross-Reference Matrix (VCRM)	<b>F</b>
7	Technical Performance Measure (TPM) Plan	<b>F</b>
8	Interface Control Documents (Intra-ICDs) [Units/Subsystems/GSE]	<b>R</b>
9	Spacecraft to Payload ICD (Internal)	<b>R</b>
10	Spacecraft to Launch Vehicle ICD (External)	<b>R</b>
11	Spacecraft to Ground Station ICD (External)	<b>R</b>
12	Systems Engineering Management Plan (SEMP)	<b>B</b>
13	Requirements Verification Plan (RVP) [V&V Plan, VCRM]	<b>B</b>
14	Interface Verification Plan (IVP)	<b>U</b>
15	Analysis & Simulation Plan (ASP)	<b>B</b>
16	Algorithm Development Plan (ADP)	<b>U</b>
17	Error Budgets & Allocation Analysis	<b>R</b>
18	Post Delivery Support Plan (PDSP)	<b>U</b>
19	Technology Insertion Plan (TIP)	<b>U</b>
20	Analysis Verification Reports	
21	Inspection Verification Reports	
22	Demonstration Verification Reports	
<b>RELIABILITY ENGINEERING</b>		
1	Reliability, Availability, Maintainability Plan (RAMP)	<b>B</b>
2	Reliability Analyses (Failure Prediction, FMEA, FMECA, SPF, etc.)	<b>B</b>
3	Critical Items List & Limited Life List	<b>B</b>
4	FRACAS/FRB Plan	<b>B</b>
<b>PARTS, MATERIALS &amp; PROCESSES (PMP) ENGINEERING</b>		
1	Parts, Material & Process (PMP) Plan	<b>R</b>
2	Approved Parts, Materials & Processes List (APMPL)	<b>R</b>
3	Major Subcontracts Plan (MSP or SCM Plan)	<b>R</b>
4	Contamination Control Plan (CCP)	<b>B</b>
<b>CONFIGURATION MANAGEMENT</b>		
1	Configuration Management Plan (CMP)	<b>R</b>
2	Data Management Plan (DMP)	<b>R</b>
<b>QUALITY ASSURANCE</b>		
1	Product Assurance Plan	<b>B</b>

<b>Critical Gated Events Work Products</b>		<b>3</b>
		<b>Critical Design Review (CDR)</b>
<b>SYSTEM SAFETY ASSURANCE</b>		
1	SSHP (System Safety & Hazard Plan) [includes Human Factors]	<b>B</b>
2	Environmental Effects Plan (EEP) [EMI/EMC Plan, Radiation Effects, etc.]	<b>B</b>
3	Electro Static Discharge Plan (ESDP) [includes Spacecraft Charging, Power Distribution & Grounding	<b>B</b>
<b>DESIGN ASSURANCE</b>		
1	Hardware Development Plan (HDP)	<b>B</b>
2	Detail Drawings	<b>B</b>
3	Assembly Drawings	<b>U</b>
4	Installation Drawings/Procedures	<b>U</b>
5	Schematics/Wiring Diagrams	<b>U</b>
6	Worst-Case Design Analyses	<b>B</b>
7	Structural, Thermal, Optical, Performance (STOP) Analyses	<b>B</b>
8	Packaging, Handling, Storage & Transportation (PHST) Plan	<b>U</b>
<b>SOFTWARE ASSURANCE</b>		
1	Software Development Plan (SDP)	<b>B</b>
2	Software Requirements Specification	<b>R</b>
3	Software Manuals	<b>U</b>
<b>MANUFACTURING ASSURANCE</b>		
1	Manufacturing Operating Plan (MOP)	<b>B</b>
2	Producibility Plan	<b>R</b>
3	Production Plan & Master Production Schedule (Capacity & Throughput Analysis)	<b>B</b>
4	Build History Planning/Work Orders	<b>B</b>
5	Kitting & Parts Status Plan	<b>B</b>
6	Facilities/Space Plan (FSP)	<b>B</b>
7	Manufacturing Facility Certification	<b>B</b>
8	Skills Training & Certification Matrix	<b>C, U</b>
9	GSE/STE/Tooling Certified/Calibrated/Proof-Loaded/PM Matrix	<b>C, U</b>
<b>INTEGRATION, TEST &amp; EVALUATION</b>		
1	Test Requirements Specification (TRS)	<b>U</b>
2	Environmental Test Requirements Specification (ETRS)	<b>U</b>
3	GSE/STE ICD (Mech/Elect/Optical/Thermal)	<b>R</b>
4	Embedded Test (BIT)/Integrated Diagnostics/ DFT Requirements	<b>U</b>

<b>Critical Gated Events Work Products</b>		<b>3</b>
		<b>Critical Design Review (CDR)</b>
5	GSE/STE Analysis, FMEA	
6	GSE/STE Metrology Plan	<b>U</b>
7	Test & Evaluation Master Plan (TEMP) [includes Design-for-Test; BIT Testing]	<b>U</b>
8	Top-Level Test Configuration Drawing	<b>U</b>
9	Thermal Vacuum Test Plan	<b>B</b>
10	EMI/EMC Test Plan	<b>B</b>
11	Vibration, Shock & Acoustics Test Plan	<b>B</b>
12	Mass Properties Test Plan	<b>B</b>
13	Test Scripts/Recipes	<b>U</b>
14	Test Procedures – Electrical (Functional)	<b>U</b>
15	Test Procedures – RF	<b>U</b>
16	Test Procedures – Optical	<b>U</b>
17	Test Procedures – Thermal Vacuum	<b>U</b>
18	Test Procedures – Thermal Balance	<b>U</b>
19	Test Procedures – Vibration/Shock	<b>U</b>
20	Test Procedures – Acoustic	<b>U</b>
21	Test Procedures – Mass Properties	<b>U</b>
22	Test Lab Certification	<b>U</b>
23	Test Verification Reports	
24	User Guides/Test Manuals	
<b>OPERATIONAL READINESS ASSURANCE</b>		
1	Pre-Launch DD-250	
2	Flight Worthiness Certification by Launch Authority	
3	Aerospace Launch Verification Letter	
4	Early On-Orbit Testing (EOT) Report	
5	SCA Change Notice	

**C = Created:** The initial generation or first draft of a work product being developed that is under author control and has not been reviewed.

**U = Updated:** A work product that contains new information, remains under author or IPT control, and has completed an informal review process by peers.

**B = Baselined:** A prepared or concluded work product that has been iterated, has IPT or program management acceptance, is ready for a formal gated event review, and may not be changed without formal CM revision control.

**R = Revised:** A reevaluated work product that has been significantly modified, remains under CM control, and will require approval authority for changes to the technical baseline.

**F = Finalized:** Brings a work product to its final state where it has been reviewed and/or signed off by the approval authority and is available for use.

## 5.6 References

- MIL- STD-1521B *Technical Reviews and Audits for Systems, Equipments, and Computer Software,*  
Department of Defense - USAF,  
4 June 1985
- NSS-03-01 *National Security Space Acquisition Policy,*  
Department of Defense - USAF,  
27 December 2004
- Aerospace TOR-2006(8506)-4494 *Space Vehicle Systems Engineering Handbook,*  
Edited by W. Englehart  
30 November 2005
- Aerospace TOR-2007(8583)-6414 (Draft) *Technical Reviews and Audits for Systems, Equipments, and Computer Software,*  
Department of Defense – USAF and  
L. Peresztegy, C. O’Connor,  
12 July 2007
- INCOSE-TP-2003-0126-02, Version 2a *Systems Engineering Handbook,*  
International Council on Systems Engineering (INCOSE),  
Technical Staff,  
1 June 2004
- Defense Acquisition University *DAU Systems Engineering Fundamentals,*  
Defense Acquisition University Press,  
1 January 2001
- NASA GSFC-STD-1001 *Criteria for Flight Project Critical Milestone Reviews,*  
Approved by R. Day,  
19 February 2005
- NASA SP-6105 *NASA Systems Engineering Handbook,*  
R. Shishko, Ph.D.,  
1 June 1995





## **6. Gate 4: Build Readiness Review (BRR)**

### **6.1 Introduction**

Space hardware requires that special precautions be taken because item failures could seriously affect system operation or cause the system to fail to achieve mission objectives (e.g., SPFs). As there are items that have very stringent performance requirements, disciplined manufacturing techniques are needed to produce these items.

To successfully produce high-quality space products, manufacturing practices and tasks require close teamwork and coordination between engineering disciplines such as systems engineering, design engineering, parts, materials and processes (PM&P) engineering, test engineering, reliability engineering, safety engineering, quality assurance, configuration management, manufacturing engineering, and manufacturing operations. This interaction between engineering disciplines starts early in the concept development phase of the program and continues prior to production of the item to be manufactured – culminating in a BRR.

The objectives for BRR are two-fold. The first objective is to ensure that the manufacturing process can produce the items and meet the specified design requirements – including any late changes due to immature design iterations, as well as incorporation of producibility changes. The second objective is to ensure that the design translates into a reliable, durable, accurate manufactured item using manufacturing processes that are highly repeatable and error-free. These objectives are typically documented in a manufacturing management plan (MMP). The MMP is maintained and updated throughout the lifecycle (prior to production) addressing all aspects of manufacturing, and it is reviewed in the BRR.

### **6.2 Purpose**

The purpose of the BRR is to determine the readiness of the manufacturer/contractor to proceed with manufacturing of the product. The review is held incrementally in preparation for the production of the CI, subsystem, and system. Specifically, the BRR is intended to: 1) identify incomplete design elements and ensure risk mitigation plans are in-place, 2) verify the design is producible and producibility-oriented changes are incorporated into the design, 3) establish production build history documentation, and balance production planning for capacity and throughput, 4) ensure production processes and methods are consistent with quality requirements and compliant with Environmental Health and Safety regulations, 5) ensure production flight parts/materials (including spares/safety stock) are qualified and received into stores and are available to meet the production plan, 6) ensure facilities are allocated and qualified, 7) ensure personnel are trained, certified, and assigned to the effort, and 8) ensure all tooling and GSE (including test equipment) is certified/calibrated/proof-loaded and ready-for-use. The BRR will also reveal if any issues, risks, and corrective actions for manufacturing have not been satisfactorily resolved prior to start of production.

### **6.3 Entrance Criteria**

1. Ensure that all major issues generated in previous major reviews/gates have been worked to closure, and for open issues a corrective action plan with detailed implementation steps has been developed and approved.
2. Verify that 100% of engineering drawings (detailed drawings, assembly/installation drawings, schematics, wire lists, etc.) and related documentation (FMECA, reliability predictions, structural/thermal/optical performance analyses, ICDs, etc.) have been updated, released, and are under configuration control.

## 6.4 Exit Criteria

1. A detailed manufacturing requirements plan (MRP) by major assembly is in-place and resource loaded against shift schedules and supportive of overall program need dates.
2. Work order and build-history planning instructions have been finalized and released for all Make items.
3. Production control status of kitted parts and material shortages has been identified.
4. Parts and materials hazards have been identified and mitigation plans in-place. A prohibited materials audit has been performed.
5. Processes are in-place to control separation of flight materials from non-flight materials to prevent co-mingling.
6. Facility and laboratory controls are in-place and meet contamination, facility electrical grounding, workstation ESD certification, environmental control (humidity, temperature, and particle count controls), and safety/hazard requirements.
7. Safety, environmental and health process risks have been identified and resolved.
8. Equipment (which includes tooling, test equipment, and GSE) is certified, calibrated, proof-loaded, and includes preventative maintenance plans.
9. Customer-owned and GFE is identified and segregated from company-owned/capital assets.
10. Sufficient skilled personnel are identified to execute production – personnel laboratory and process certifications are in-place and current.
11. Build risk burn-down and mitigation/recovery plans are considered credible and agreed upon by stakeholders.

## 6.5 Work Products

Within the BRR phase, the following work products are defined and stasured as follows in Table 4:

Table 4. Work Product Matrix Detail #4

<b>Critical Gated Events Work Products</b>		<b>4</b>
		<b>Build Readiness Review (BRR)</b>
<b>MISSION ASSURANCE</b>		
1	Mission Assurance Plan	<b>F</b>
2	Risk Management Plan (RMP)	<b>R</b>
3	Program Management Plan (PMP)	<b>R</b>
<b>REQUIREMENTS, ANALYSIS &amp; VALIDATION</b>		
1	Concept of Operations (CONOPS) Plan	<b>F</b>
2	System Architecture (Block Diagrams & Functional Flow Diagrams)	<b>F</b>
3	A-Specification for System Functional Baseline	<b>F</b>
4	B-Specifications for Development	<b>F</b>
5	C-Specifications for Configured Items (Units/Components/Processes)	<b>R</b>
6	Verification Cross-Reference Matrix (VCRM)	<b>F</b>
7	Technical Performance Measure (TPM) Plan	<b>F</b>

<b>Critical Gated Events Work Products</b>		<b>4</b>
		<b>Build Readiness Review (BRR)</b>
8	Interface Control Documents (Intra-ICDs) [Units/Subsystems/GSE]	R
9	Spacecraft to Payload ICD (Internal)	R
10	Spacecraft to Launch Vehicle ICD (External)	R
11	Spacecraft to Ground Station ICD (External)	R
12	Systems Engineering Management Plan (SEMP)	F
13	Requirements Verification Plan (RVP) [V&V Plan, VCRM]	R
14	Interface Verification Plan (IVP)	B
15	Analysis & Simulation Plan (ASP)	F
16	Algorithm Development Plan (ADP)	B
17	Error Budgets & Allocation Analysis	R
18	Post Delivery Support Plan (PDSP)	U
19	Technology Insertion Plan (TIP)	U
20	Analysis Verification Reports	C
21	Inspection Verification Reports	C
22	Demonstration Verification Reports	C
<b>RELIABILITY ENGINEERING</b>		
1	Reliability, Availability, Maintainability Plan (RAMP)	R
2	Reliability Analyses (Failure Prediction, FMEA, FMECA, SPF, etc.)	R
3	Critical Items List & Limited Life List	R
4	FRACAS/FRB Plan	B
<b>PARTS, MATERIALS &amp; PROCESSES (PMP) ENGINEERING</b>		
1	Parts, Material & Process (PMP) Plan	F
2	Approved Parts, Materials & Processes List (APMPL)	R
3	Major Subcontracts Plan (MSP or SCM Plan)	F
4	Contamination Control Plan (CCP)	R
<b>CONFIGURATION MANAGEMENT</b>		
1	Configuration Management Plan (CMP)	R
2	Data Management Plan (DMP)	R
<b>QUALITY ASSURANCE</b>		
1	Product Assurance Plan	R
<b>SYSTEM SAFETY ASSURANCE</b>		
1	SSHP (System Safety & Hazard Plan) [includes Human Factors]	R
2	Environmental Effects Plan (EEP) [EMI/EMC Plan, Radiation Effects, etc.]	R

<b>Critical Gated Events Work Products</b>		<b>4</b>
		<b>Build Readiness Review (BRR)</b>
3	Electro Static Discharge Plan (ESDP) [includes Spacecraft Charging, Power Distribution & Grounding	<b>R</b>
<b>DESIGN ASSURANCE</b>		
1	Hardware Development Plan (HDP)	<b>R</b>
2	Detail Drawings	<b>R</b>
3	Assembly Drawings	<b>B</b>
4	Installation Drawings/Procedures	<b>B</b>
5	Schematics/Wiring Diagrams	<b>B</b>
6	Worst-Case Design Analyses	<b>R</b>
7	Structural, Thermal, Optical, Performance (STOP) Analyses	<b>R</b>
8	Packaging, Handling, Storage & Transportation (PHST) Plan	<b>B</b>
<b>SOFTWARE ASSURANCE</b>		
1	Software Development Plan (SDP)	<b>R</b>
2	Software Requirements Specification	<b>R</b>
3	Software Manuals	<b>B</b>
<b>MANUFACTURING ASSURANCE</b>		
1	Manufacturing Operating Plan (MOP)	<b>R</b>
2	Producibility Plan	<b>F</b>
3	Production Plan & Master Production Schedule (Capacity & Throughput Analysis)	<b>R</b>
4	Build History Planning/Work Orders	<b>R</b>
5	Kitting & Parts Status Plan	<b>R</b>
6	Facilities/Space Plan (FSP)	<b>R</b>
7	Manufacturing Facility Certification	<b>R</b>
8	Skills Training & Certification Matrix	<b>B</b>
9	GSE/STE/Tooling Certified/Calibrated/Proof-Loaded/PM Matrix	<b>B</b>
<b>INTEGRATION, TEST &amp; EVALUATION</b>		
1	Test Requirements Specification (TRS)	<b>B</b>
2	Environmental Test Requirements Specification (ETRS)	<b>B</b>
3	GSE/STE ICD (Mech/Elect/Optical/Thermal)	<b>R</b>
4	Embedded Test (BIT)/Integrated Diagnostics/ DFT Requirements	<b>B</b>
5	GSE/STE Analysis, FMEA	<b>B</b>
6	GSE/STE Metrology Plan	<b>B</b>
7	Test & Evaluation Master Plan (TEMP) [includes Design-for-Test; BIT Testing]	<b>U</b>
8	Top-Level Test Configuration Drawing	<b>B</b>

Critical Gated Events Work Products		4
		Build Readiness Review (BRR)
9	Thermal Vacuum Test Plan	R
10	EMI/EMC Test Plan	R
11	Vibration, Shock & Acoustics Test Plan	R
12	Mass Properties Test Plan	R
13	Test Scripts/Recipes	B
14	Test Procedures – Electrical (Functional)	B
15	Test Procedures – RF	B
16	Test Procedures – Optical	B
17	Test Procedures – Thermal Vacuum	B
18	Test Procedures – Thermal Balance	B
19	Test Procedures – Vibration/Shock	B
20	Test Procedures – Acoustic	B
21	Test Procedures – Mass Properties	B
22	Test Lab Certification	B
23	Test Verification Reports	C
24	User Guides/Test Manuals	
<b>OPERATIONAL READINESS ASSURANCE</b>		
1	Pre-Launch DD-250	
2	Flight Worthiness Certification by Launch Authority	
3	Aerospace Launch Verification Letter	
4	Early On-Orbit Testing (EOT) Report	
5	SCA Change Notice	

**C = Created:** The initial generation or first draft of a work product being developed that is under author control and has not been reviewed.

**U = Updated:** A work product that contains new information, remains under author or IPT control, and has completed an informal review process by peers.

**B = Baselined:** A prepared or concluded work product that has been iterated, has IPT or program management acceptance, is ready for a formal gated event review, and may not be changed without formal CM revision control.

**R = Revised:** A reevaluated work product that has been significantly modified, remains under CM control, and will require approval authority for changes to the technical baseline.

**F = Finalized:** Brings a work product to its final state where it has been reviewed and/or signed off by the approval authority and is available for use.

## 6.6 References

Aerospace TOR-2007(8546)-6018

*Mission Assurance Guide,*  
Edited by S. Guarro and W. Tosney  
1 July 2007

Aerospace TOR-2006(8546)-4591

*Space Vehicle Test and Evaluation Handbook,*  
Edited by D. Hanifen, A. Peterson, and W. Tosney  
6 November 2006

Aerospace TOR-2006(8506)-4494	<i>Space Vehicle Systems Engineering Handbook</i> , Edited by W. Englehart 30 November 2005
INCOSE-TP-2003-0126-02, Version 2a	<i>Systems Engineering Handbook</i> , International Council on Systems Engineering (INCOSE) Technical Staff, 1 June 2004
Defense Acquisition University	<i>DAU Systems Engineering Fundamentals</i> , Defense Acquisition University Press, 1 January 2001
NASA GSFC-STD-1001	<i>Criteria for Flight Project Critical Milestone Reviews</i> , Approved by R. Day, 19 February 2005
NASA SP-6105	<i>NASA Systems Engineering Handbook</i> , R. Shishko, Ph.D., 1 June 1995

## 7. Gate 5: Test Evaluation Campaign Review (TECR)

### 7.1 Introduction

The TEC encompasses a number of gated events, including TECR, BIST RR, and PER, as well as any supporting lower-level or additional reviews held at the discretion of the program. The TEC defines the overall testing strategy, testing V&V plans, and work products needed to validate the test requirements of the space vehicle. The TEC activities are held throughout the manufacturing build and test phase of the program leading up to sell-off and mission preparation.

The TECR is a gated event which is held to verify that the program is prepared to proceed with formal testing. The review verifies that the planned testing meets all assigned verification or validation requirements, and that the test documentation, test hardware, test software, and test resources are ready for test operations. The timing of the TECR is dependent upon the risk associated with the test program. If the program has significantly new development content, the TECR should be conducted early in the build and test phase of the program. In that case, the TECR can be held in association with the program's CDR, or shortly thereafter, to ensure that the V&V planning, strategies, architecture, work products, and tasks are defined and appropriately planned and scheduled for test execution. The maturity of the test program and risks to the program are addressed at this review.

Alternatively, the TECR can be held later in the program prior to testing units, assemblies, subsystems, modules, or the space vehicle when these products are ready to be tested and verified. The TECR at this stage reviews the previous test and evaluation results of lower-level testing for test validation, liens, discrepancies, anomalies, unverified failures, and risks prior to proceeding to the next level of testing. A program may choose to conduct more than one TECR depending on the level of risk associated with the testing.

At the space vehicle level, the TECR specifically addresses the final integration of all the major subsystems of the delivered product. The TECR focuses on the test plan finalization, test equipment validation and associated equipment checkout (including cables), released test procedures, validated test scripts, and flight hardware readiness to proceed to the system level, or the mechanically integrated spacecraft bus and payload testing.

The purpose of the TECR is to verify end item requirements satisfaction (e.g., functionality, performance, design/construction, interfaces, and environment). This includes not only the obvious assembly and test of flight systems and supporting GSE, but also through evaluation, the use of analytical methods to certify requirements satisfaction. Test data collected at the lower levels, such as at the subsystem level, has been reviewed and analyzed for compliance to requirements. At the space vehicle level, test, demonstration, simulation, and analysis are used in appropriate combination to provide discernible evidence of compliance. The final step for space hardware is system (mechanically integrated bus and payload) validation, which again uses a combination of test, analysis (and in some cases, simulation), to certify that the user's needs have been met under operational service conditions.

Test planning begins during the early concept and requirements definition phase and continues through the qualification, production, and operational test phases of a program. Flight software and ground system test planning continues through operations and maintenance. Test planning requires that the system operational environments, modes, states, redundancies, risks, and failure modes are well understood, and focuses the test program in those areas to perceptively identify or validate the absence of defects and problems affecting mission success.

Functional and performance testing is typically used to verify electrical, mechanical, digital, signal, radio frequency, optical, and other mission performance parameters against the stated requirements under operational service conditions. Functional and performance tests performed before, during, and after environmental tests are used to verify performance under worst-case service conditions and to verify that the environmental stress testing did not change test article performance or mature latent defects into detectable flaws.

A test risk assessment begins early in the product lifecycle of a typical space program. This assessment is primarily focused on resolving three issues. First, test risk assessment evaluates the key risks to mission success and determines if test is the best verification method to verify unit, subsystem, and system requirements. The assessment includes consideration of risk and confidence should another verification method (e.g., analysis, similarity, inspection, or demonstration) be chosen due to program constraints. Second, test risk assessment examines the risk to the flight hardware undergoing the proposed test program to avoid overstressing the test article. Finally, test risk assessment evaluates each test for each proposed test article to ensure that the test program adequately exercises the combined software/hardware for nominal and off-nominal operating states, modes, potential redundancies, and failures in both nominal and off-nominal (worst-case) operational environments.

A successful test program includes interaction with failure review and corrective action system (FRACAS) as an orderly method to capture and report test failures, associate failures with root cause(s), track the implementation of corrective actions to remediate failures, and track required retests to verify that the cause(s) of the failures have been corrected. A failure review board (FRB) is an established process and may be comprised of contractors, subcontractors or suppliers, the government program office, and consultants to coordinate the review of all significant failure reports, review failure trends, track and review the timely implementation of corrective actions, and provide closeout approval for reported failures.

Space systems integration tasks are required to evaluate whether the contractor's process, sequencing, and schedules successfully build-up the space vehicle from the lowest level of assembly to a fully integrated system. Space system testing tasks include evaluation of contractor tasks to successfully demonstrate system functionality, interface compatibility, and perform and/or certify the unit, subsystem (if applicable), and system for the service environment (e.g., factory, transportation, launch base, launch, and on-orbit). Also included are the activities to validate and certify all supporting GSE and/or test equipment prior to use.

## **7.2 Purpose**

The purpose of the TECR is to determine the readiness of the program to proceed with formal testing. Specifically, the TECR is intended to: 1) provide evidence of completion that the as-built system (including interfaces) satisfies the requirements and specification baseline; 2) assure there are no major issues with the proposed test, integration, and verification plans and procedures; 3) assure that the risks are understood with deviations from environmental testing standards such as MIL-STD-1540; 4) assure that the test program contains the fidelity of the "test like you fly" (TLYF) philosophy, especially at the space vehicle and higher levels of integration, including the implications to accurate modeling and simulation; 5) assess the degree to which the requirements are objectively verifiable and correct unverifiable requirements; and 6) evaluate analysis, simulation, inspection, and test results to determine readiness to proceed to subsequent test or program activities. The TECR will also reveal if any issues, risks, and corrective actions for test design, have been satisfactorily resolved prior to start of system-level testing.



### 7.3 Entrance Criteria

1. All major issues generated in previous major reviews/gates have been worked to closure, and for open issues a corrective action plan with detailed implementation steps has been developed and approved.
2. Remaining open specification TBD items and plans for closing them have been identified.
3. Post-CDR changes to detailed functional block diagrams, schematics, circuit design, thermal design, test access, STE module/circuit board replacement, choice of connector and connector pins, and preliminary timing analyses have been reviewed.
4. CI and subsystem hardware and software test data have been reviewed and meet acceptance criteria.
5. Qualification testing and verification of compliance with performance and environmental specifications (including software) has been completed.

### 7.4 Exit Criteria

1. Electro-magnetic environment (EME) requirements (including radiated fields, conducted interference, electro-static discharge, electro-magnetic pulse, etc.) are traceable to top-level specifications.
2. Analyses used to establish test tolerances (including error tree budget flowdown from prime flight hardware) have been verified and meet requirements.
3. Test product performance requirements (including fault detection, fault isolation, fault isolation time, maximum test time, and the relationship of these requirements to the design-for-test (DFT)) have been defined.
4. VCRM review:
  - a) For requirements that are verified by test, identify whether the test is a one-time design verification test (DVT), a qualification test (QT), or a recurring acceptance test (AT) to be performed for the system.
  - b) Finalize all development and production test equipment, including hardware and software elements – including capital and contract funded-STE.
  - c) Ensure requirements for embedded test (BIT), integrated diagnostics, and design for testability (DFT) approaches are defined.
5. All test equipment (electrical/optical/mechanical, etc.) is in-place to perform system-level proof-of-design and production testing.
6. Equipment (including tooling and test equipment) is certified, calibrated, proof-loaded, and includes preventative maintenance plans.
7. All development and production test procedures have been reviewed and baselined.
8. User guides, operation manuals, and CONOPS documents are finalized. Note: The CONOPS document is finalized by PDR but gets revised to incorporate TLYF and TEC development ideas.
9. A top-level system test configuration drawing has been baselined.
10. Facility and laboratory controls are in-place and meet contamination, facility electrical grounding, workstation ESD certification, environmental controls (humidity, temperature, and particle count controls), and safety/hazard requirements.
11. Safety, environmental and health process risks have been identified and resolved (e.g., electrical safety, confined spaces, chamber safety, etc.).
12. Detailed integration and test schedules for the space vehicle level have been resource loaded against shift schedules and are supportive of overall program need dates.
13. Sufficiently skilled personnel have been identified to execute production – personnel, laboratory and process certifications are in-place/current.

14. Lessons learned from previous test programs have been incorporated into the TECR to improve test process efficiency, maximize flight and personnel safety, and ensure verification by test objectives are met.
15. TECR risk burn-down and mitigation/recovery plans are considered credible and agreed upon by stakeholders.

## 7.5 Work Products

Work products will vary depending upon the stage in the program/project when the TECR is held. The products identified in Table 5 (defined and stated as follows) are the final documents generated prior to entering sell-off and mission preparation.

Table 5. Work Product Matrix Detail #5

<b>Critical Gated Events Work Products</b>		<b>5</b>
		<b>Test Evaluation Campaign Review (TECR)</b>
<b>MISSION ASSURANCE</b>		
1	Mission Assurance Plan	<b>F</b>
2	Risk Management Plan (RMP)	<b>R</b>
3	Program Management Plan (PMP)	<b>R</b>
<b>REQUIREMENTS, ANALYSIS &amp; VALIDATION</b>		
1	Concept of Operations (CONOPS) Plan	<b>F</b>
2	System Architecture (Block Diagrams & Functional Flow Diagrams)	<b>F</b>
3	A-Specification for System Functional Baseline	<b>F</b>
4	B-Specifications for Development	<b>F</b>
5	C-Specifications for Configured Items (Units/Components/Processes)	<b>F</b>
6	Verification Cross-Reference Matrix (VCRM)	<b>F</b>
7	Technical Performance Measure (TPM) Plan	<b>F</b>
8	Interface Control Documents (Intra-ICDs) [Units/Subsystems/GSE]	<b>R</b>
9	Spacecraft to Payload ICD (Internal)	<b>R</b>
10	Spacecraft to Launch Vehicle ICD (External)	<b>R</b>
11	Spacecraft to Ground Station ICD (External)	<b>R</b>
12	Systems Engineering Management Plan (SEMP)	<b>F</b>
13	Requirements Verification Plan (RVP) [V&V Plan, VCRM]	<b>R</b>
14	Interface Verification Plan (IVP)	<b>R</b>
15	Analysis & Simulation Plan (ASP)	<b>F</b>
16	Algorithm Development Plan (ADP)	<b>R</b>
17	Error Budgets & Allocation Analysis	<b>R</b>
18	Post Delivery Support Plan (PDSP)	<b>B</b>
19	Technology Insertion Plan (TIP)	<b>B</b>
20	Analysis Verification Reports	<b>B</b>

<b>Critical Gated Events Work Products</b>		<b>5</b>
		<b>Test Evaluation Campaign Review (TECR)</b>
21	Inspection Verification Reports	<b>B</b>
22	Demonstration Verification Reports	<b>B</b>
<b>RELIABILITY ENGINEERING</b>		
1	Reliability, Availability, Maintainability Plan (RAMP)	<b>R</b>
2	Reliability Analyses (Failure Prediction, FMEA, FMECA, SPF, etc.)	<b>R</b>
3	Critical Items List & Limited Life List	<b>R</b>
4	FRACAS/FRB Plan	<b>R</b>
<b>PARTS, MATERIALS &amp; PROCESSES (PMP) ENGINEERING</b>		
1	Parts, Material & Process (PMP) Plan	<b>F</b>
2	Approved Parts, Materials & Processes List (APMPL)	<b>R</b>
3	Major Subcontracts Plan (MSP or SCM Plan)	<b>F</b>
4	Contamination Control Plan (CCP)	<b>R</b>
<b>CONFIGURATION MANAGEMENT</b>		
1	Configuration Management Plan (CMP)	<b>F</b>
2	Data Management Plan (DMP)	<b>F</b>
<b>QUALITY ASSURANCE</b>		
1	Product Assurance Plan	<b>F</b>
<b>SYSTEM SAFETY ASSURANCE</b>		
1	SSHP (System Safety & Hazard Plan) [includes Human Factors]	<b>F</b>
2	Environmental Effects Plan (EEP) [EMI/EMC Plan, Radiation Effects, etc.]	<b>F</b>
3	Electro Static Discharge Plan (ESDP) [includes Spacecraft Charging, Power Distribution & Grounding]	<b>F</b>
<b>DESIGN ASSURANCE</b>		
1	Hardware Development Plan (HDP)	<b>R</b>
2	Detail Drawings	<b>R</b>
3	Assembly Drawings	<b>R</b>
4	Installation Drawings/Procedures	<b>R</b>
5	Schematics/Wiring Diagrams	<b>R</b>
6	Worst-Case Design Analyses	<b>R</b>
7	Structural, Thermal, Optical, Performance (STOP) Analyses	<b>R</b>
8	Packaging, Handling, Storage & Transportation (PHST) Plan	<b>R</b>

<b>Critical Gated Events Work Products</b>		<b>5</b>
		<b>Test Evaluation Campaign Review (TECR)</b>
<b>SOFTWARE ASSURANCE</b>		
1	Software Development Plan (SDP)	R
2	Software Requirements Specification	R
3	Software Manuals	R
<b>MANUFACTURING ASSURANCE</b>		
1	Manufacturing Operating Plan (MOP)	R
2	Producibility Plan	F
3	Production Plan & Master Production Schedule (Capacity & Throughput Analysis)	F
4	Build History Planning/Work Orders	F
5	Kitting & Parts Status Plan	F
6	Facilities/Space Plan (FSP)	F
7	Manufacturing Facility Certification	F
8	Skills Training & Certification Matrix	R
9	GSE/STE/Tooling Certified/Calibrated/Proof-Loaded/PM Matrix	R
<b>INTEGRATION, TEST &amp; EVALUATION</b>		
1	Test Requirements Specification (TRS)	R
2	Environmental Test Requirements Specification (ETRS)	R
3	GSE/STE ICD (Mech/Elect/Optical/Thermal)	F
4	Embedded Test (BIT)/Integrated Diagnostics/ DFT Requirements	R
5	GSE/STE Analysis, FMEA	R
6	GSE/STE Metrology Plan	R
7	Test & Evaluation Master Plan (TEMP) [includes Design-for-Test; BIT Testing]	B
8	Top-Level Test Configuration Drawing	R
9	Thermal Vacuum Test Plan	R
10	EMI/EMC Test Plan	R
11	Vibration, Shock & Acoustics Test Plan	R
12	Mass Properties Test Plan	R
13	Test Scripts/Recipes	R
14	Test Procedures – Electrical (Functional)	R
15	Test Procedures – RF	R
16	Test Procedures – Optical	R
17	Test Procedures – Thermal Vacuum	R
18	Test Procedures – Thermal Balance	R
19	Test Procedures – Vibration/Shock	R
20	Test Procedures – Acoustic	R
21	Test Procedures – Mass Properties	R
22	Test Lab Certification	F

<b>Critical Gated Events Work Products</b>		<b>5</b>
		<b>Test Evaluation Campaign Review (TECR)</b>
23	Test Verification Reports	<b>B</b>
24	User Guides/Test Manuals	<b>C</b>
<b>OPERATIONAL READINESS ASSURANCE</b>		
1	Pre-Launch DD-250	
2	Flight Worthiness Certification by Launch Authority	
3	Aerospace Launch Verification Letter	
4	Early On-Orbit Testing (EOT) Report	
5	SCA Change Notice	

**C = Created:** The initial generation or first draft of a work product being developed that is under author control and has not been reviewed.

**U = Updated:** A work product that contains new information, remains under author or IPT control, and has completed an informal review process by peers.

**B = Baselined:** A prepared or concluded work product that has been iterated, has IPT or program management acceptance, is ready for a formal gated event review, and may not be changed without formal CM revision control.

**R = Revised:** A reevaluated work product that has been significantly modified, remains under CM control, and will require approval authority for changes to the technical baseline.

**F = Finalized:** Brings a work product to its final state where it has been reviewed and/or signed off by the approval authority and is available for use.

## 7.6 References

Aerospace TOR-2007(8546)-6018	Mission Assurance Guide, Edited by S. Guarro and W. Tosney 1 July 2007
Aerospace TOR-2006(8546)-4591	Space Vehicle Test and Evaluation Handbook, Edited by D. Hanifen, A. Peterson, and W. Tosney 6 November 2006
INCOSE-TP-2003-0126-02, Version 2a	Systems Engineering Handbook, International Council on Systems Engineering (INCOSE) Technical Staff, 1 June 2004
Defense Acquisition University	DAU Systems Engineering Fundamentals, Defense Acquisition University Press, 1 January 2001
NASA GSFC-STD-1001	Criteria for Flight Project Critical Milestone Reviews, Approved by R. Day, 19 February 2005
NASA SP-6105	NASA Systems Engineering Handbook, R. Shishko, Ph.D., 1 June 1995



## 8. Gate 6: Assembly/Integration Readiness Review (BIST RR)

### 8.1 Introduction

This review is conducted before initial system test or BIST, and after successful completion of all items enumerated in the TCER. It ascertains the readiness of the integrated space vehicle (spacecraft and payload) to undergo system-level testing.

### 8.2 Purpose

Specific Assembly/Integration Readiness Review (BIST RR) assessment criteria include the completeness of the flight system; compatibility between the spacecraft and the payload; the readiness of test facilities, test procedures, and special test equipment to support system-level testing; the adequacy of documentation; planning for closure of all remaining problems, waivers or liens; and the readiness of the integration and test team to support system-level testing. Additional goals, such as validation of ground segment connectivity, may apply or be conducted concurrently. The intent of the review is to ensure that major hardware and computer software elements of a system will be assembled/integrated, tested, and operated in such a manner as to be compatible with each other and to satisfy system objectives.

### 8.3 Entrance Criteria

1. Successful completion of all items enumerated in the TCER.
2. Spacecraft (bus) and payload have met their respective verification criteria and are present in configurations very close to flight.
3. Availability of the following documents:
  - Finalized requirements verification plan (RVP and VCRM)
  - Detailed BIST test requirement specifications (TRS)
  - Finalized spacecraft-to-payload ICD
  - Updated space vehicle CONOPS, including:
    - Space vehicle operational constraint document
    - Payload operational constraint document
    - Software threads
  - Description of bus and payload operation history prior to mating, including trending data (to give confidence that they will function satisfactorily during BIST)
  - Description of the integrated system status, including:
    - Deviations from mission configuration
    - Use of placeholders and non-flight items, ways to ensure completion of flight configuration and verify flight item performance
    - Configuration management control status
    - Open liens
    - Status of flight hardware and software with respect to readiness for BIST
    - Status of in-progress engineering changes, operations orders, manufacturing process plan, build plans, build logs, shop orders, and other engineering documents.
  - Detailed BIST procedures that:
    - Describe test sequences, events, operations, script, test levels, and expected results
    - Delineate combined spacecraft/payload operations including safe-to-mate, payload purging, test limits, and end-to-end testing

- List all safety issues such as the handling of initial mating, pyros, high-voltage equipment, and batteries, as well as mitigations thereof
- Describe contingency operations such as abort plans with analysis showing that flight hardware will not be overstressed during such operations
- Explain how open liens and operational constraints are considered in the BIST procedure
- Discuss risk mitigation approaches such as performing dry runs with the test scripts in a testbed
- Address conformances and exceptions to key guidance documents related to special testing, such as those pertinent to moving mechanical assemblies, explosive ordnance, electro-explosives, EMI, EMC, pressurized equipment, and solar cell arrays
- Specify TLYF exceptions and mitigation approach
- Description of test software and database, including:
  - Adequacy and readiness of test software
  - Data reduction software
  - Updated engineering release database
  - Test cases and manuals
  - Commercial-off-the-shelf (COTS) items
  - TLYF exceptions
- Description of test facility and test equipment availability, including:
  - Test facility assessment including a safety analysis that evaluates possible damage (such as contamination) to flight hardware
  - Security plan, including classification and communication security (COMSEC) considerations embodied in the test facility and test equipment
  - Test facility maintenance and inspection report
  - ICDs for electrical GSE and mechanical GSE
  - Test equipment readiness, sufficiency, calibration, maintenance, and inspection report
  - FMEA of test equipment that addresses possible damage to flight hardware
  - Safe-to-mate procedures including, for example, pin function map
  - Configuration of GSE
  - Metrology plan, requirements, and analysis of GSE
  - Availability of redundant instrumentation and contingency planning
  - Warning and maximum levels such as critical test parameter settings, monitors, and yellow/redline limits, and alarms
  - ESD equipment and procedures
  - Operational manuals for the EGSE and MGSE
- Test personnel readiness, including:
  - Required skills, certification, and special training (e.g., ESD)
  - Operations and shift change policy
  - Availability of personnel
  - Identification of safety issues and mitigation thereof
- Test schedule and resources requirements, including:
  - Start date and task spans
  - Shifts involved
  - Post-test data evaluation, including applicable customer review
  - Justification of schedule and resource allocation based on hardware complexity and comparison against similar programs
- Non-conformance (see FRACAS and FRB plan) handling plan:
  - Procedures and personnel planning to handle test discrepancies and to troubleshoot



- Readiness of other resources (optional, necessary when other resources are engaged in the BIST, such as to test telemetry, tracking, and control (TT&C) interface with ground stations (readiness criteria are project-unique)

#### 8.4 Exit Criteria

1. Successful review of the documents listed above by the contractor and customer.
2. Closure (or plans and schedule to closure prior to beginning of BIST) of all open actions and liens such as test discrepancies and conditional accept tags.

#### 8.5 Work Products

Within the BIST RR phase, the following work products are defined and stasured as follows in Table 6:

Table 6. Work Product Matrix Detail #6

<b>Critical Gated Events Work Products</b>		<b>6</b>
		<b>Baseline Integrated Systems Test (BIST)</b>
<b>MISSION ASSURANCE</b>		
1	Mission Assurance Plan	<b>F</b>
2	Risk Management Plan (RMP)	<b>F</b>
3	Program Management Plan (PMP)	<b>R</b>
<b>REQUIREMENTS, ANALYSIS &amp; VALIDATION</b>		
1	Pre-Launch DD-250	<b>F</b>
2	Flight Worthiness Certification by Launch Authority	<b>F</b>
3	Aerospace Launch Verification Letter	<b>F</b>
4	Early On-Orbit Testing (EOT) Report	<b>F</b>
5	SCA Change Notice	<b>F</b>
6	Pre-Launch DD-250	<b>F</b>
7	Flight Worthiness Certification by Launch Authority	<b>F</b>
8	Aerospace Launch Verification Letter	<b>F</b>
9	Early On-Orbit Testing (EOT) Report	<b>F</b>
10	SCA Change Notice	<b>F</b>
11	Pre-Launch DD-250	<b>F</b>
12	Flight Worthiness Certification by Launch Authority	<b>F</b>
13	Aerospace Launch Verification Letter	<b>F</b>
14	Early On-Orbit Testing (EOT) Report	<b>F</b>
15	SCA Change Notice	<b>F</b>
16	Pre-Launch DD-250	<b>F</b>
17	Flight Worthiness Certification by Launch Authority	<b>F</b>
18	Aerospace Launch Verification Letter	<b>R</b>
19	Early On-Orbit Testing (EOT) Report	<b>R</b>
20	SCA Change Notice	<b>R</b>
21	Pre-Launch DD-250	<b>R</b>
22	Flight Worthiness Certification by Launch Authority	<b>R</b>

<b>Critical Gated Events Work Products</b>		<b>6</b>
		<b>Baseline Integrated Systems Test (BIST)</b>
<b>RELIABILITY ENGINEERING</b>		
1	Reliability, Availability, Maintainability Plan (RAMP)	R
2	Reliability Analyses (Failure Prediction, FMEA, FMECA, SPF, etc.)	R
3	Critical Items List & Limited Life List	R
4	FRACAS/FRB Plan	R
<b>PARTS, MATERIALS &amp; PROCESSES (PMP) ENGINEERING</b>		
1	Parts, Material & Process (PMP) Plan	F
2	Approved Parts, Materials & Processes List (APMPL)	F
3	Major Subcontracts Plan (MSP or SCM Plan)	F
4	Contamination Control Plan (CCP)	F
<b>CONFIGURATION MANAGEMENT</b>		
1	Configuration Management Plan (CMP)	F
2	Data Management Plan (DMP)	F
<b>QUALITY ASSURANCE</b>		
1	Product Assurance Plan	F
<b>SYSTEM SAFETY ASSURANCE</b>		
1	SSHP (System Safety & Hazard Plan) [includes Human Factors]	F
2	Environmental Effects Plan (EEP) [EMI/EMC Plan, Radiation Effects, etc.]	F
3	Electro Static Discharge Plan (ESDP) [includes Spacecraft Charging, Power Distribution & Grounding]	F
<b>DESIGN ASSURANCE</b>		
1	Hardware Development Plan (HDP)	F
2	Detail Drawings	F
3	Assembly Drawings	F
4	Installation Drawings/Procedures	F
5	Schematics/Wiring Diagrams	F
6	Worst-Case Design Analyses	F
7	Structural, Thermal, Optical, Performance (STOP) Analyses	F
8	Packaging, Handling, Storage & Transportation (PHST) Plan	F
<b>SOFTWARE ASSURANCE</b>		
1	Software Development Plan (SDP)	F
2	Software Requirements Specification	F
3	Software Manuals	F

<b>Critical Gated Events Work Products</b>		<b>6</b>
		<b>Baseline Integrated Systems Test (BIST)</b>
<b>MANUFACTURING ASSURANCE</b>		
1	Manufacturing Operating Plan (MOP)	F
2	Producibility Plan	F
3	Production Plan & Master Production Schedule (Capacity & Throughput Analysis)	F
4	Build History Planning/Work Orders	F
5	Kitting & Parts Status Plan	F
6	Facilities/Space Plan (FSP)	F
7	Manufacturing Facility Certification	F
8	Skills Training & Certification Matrix	R
9	GSE/STE/Tooling Certified/Calibrated/Proof-Loaded/PM Matrix	R
<b>INTEGRATION, TEST &amp; EVALUATION</b>		
1	Test Requirements Specification (TRS)	F
2	Environmental Test Requirements Specification (ETRS)	F
3	GSE/STE ICD (Mech/Elect/Optical/Thermal)	F
4	Embedded Test (BIT)/Integrated Diagnostics/ DFT Requirements	F
5	GSE/STE Analysis, FMEA	F
6	GSE/STE Metrology Plan	F
7	Test & Evaluation Master Plan (TEMP) [includes Design-for-Test; BIT Testing]	F
8	Top-Level Test Configuration Drawing	F
9	Thermal Vacuum Test Plan	F
10	EMI/EMC Test Plan	F
11	Vibration, Shock & Acoustics Test Plan	F
12	Mass Properties Test Plan	F
13	Test Scripts/Recipes	R
14	Test Procedures – Electrical (Functional)	R
15	Test Procedures – RF	R
16	Test Procedures – Optical	R
17	Test Procedures – Thermal Vacuum	R
18	Test Procedures – Thermal Balance	R
19	Test Procedures – Vibration/Shock	R
20	Test Procedures – Acoustic	R
21	Test Procedures – Mass Properties	R
22	Test Lab Certification	F
23	Test Verification Reports	R
24	User Guides/Test Manuals	B

<b>Critical Gated Events Work Products</b>		<b>6</b>
		<b>Baseline Integrated Systems Test (BIST)</b>
<b>OPERATIONAL READINESS ASSURANCE</b>		
1	Pre-Launch DD-250	
2	Flight Worthiness Certification by Launch Authority	
3	Aerospace Launch Verification Letter	
4	Early On-Orbit Testing (EOT) Report	
5	SCA Change Notice	

**C = Created:** The initial generation or first draft of a work product being developed that is under author control and has not been reviewed.

**U = Updated:** A work product that contains new information, remains under author or IPT control, and has completed an informal review process by peers.

**B = Baselined:** A prepared or concluded work product that has been iterated, has IPT or program management acceptance, is ready for a formal gated event review, and may not be changed without formal CM revision control.

**R = Revised:** A reevaluated work product that has been significantly modified, remains under CM control, and will require approval authority for changes to the technical baseline.

**F = Finalized:** Brings a work product to its final state where it has been reviewed and/or signed off by the approval authority and is available for use.

## 8.6 References

- Aerospace TOR-2004(3909)-3360, Rev. 1     *System Engineer's Major Reviews for National Security Space System Programs*,  
T. Hoang,  
2 February 2005
- Aerospace TOR-2006(8506)-4494     *Space Vehicle Test and Evaluation Handbook*,  
Edited by W. Englehart  
30 November 2005
- Aerospace TOR-2006(8546)-4591     *Space Vehicle Test and Evaluation Handbook*,  
Edited by D. Hanifen, A. Peterson, and W. Tosney  
6 November 2006
- Aerospace TOR-2005(3901)-3797     *Verification Requirements for Space Vehicles*,  
S. Nagano,  
15 December 2005
- Aerospace TOR-2004(3901)-3242     *General Guideline for Space Vehicle Verification Plan Development and Execution*,  
S. Nagano,  
15 March 2004

SMC-TR-06-11	<i>Test Requirements for Launch, Upper-Stage, And Space Vehicles,</i> TBS, 6 September 2006
MIL- HDBK- 340A	<i>Test Requirements for Launch, Upper-Stage, And Space Vehicles,</i> Department of Defense - USAF, 1 April 1999
NASA GSFC-STD-1001	<i>Criteria for Flight Project Critical Milestone Reviews,</i> Approved by R. Day, 19 February 2005
ECSS-E-10-03A	<i>Testing,</i> European Cooperation for Space Standardization, 15 February 2002
ECSS-E-10-02A	<i>Verification,</i> European Cooperation for Space Standardization, 17 November 1998



## 9. Gate 7: Pre-Environmental Review (PER)

### 9.1 Introduction

The PER is performed before the start of formal environmental testing of the integrated space vehicle to demonstrate that the vehicle has sufficient margin to permit environmental testing.

### 9.2 Purpose

Environment tests, if not well planned, can overstress flight hardware. PER assessment criteria thus focus on the readiness of test facilities, test procedures, and special test equipment to support system-level testing without causing harm.

### 9.3 Entrance Criteria

1. Completion of BIST.
2. Availability of the following documents:
  - Finalized RVP and VCRM
  - Finalized TRS
  - Finalized spacecraft-to-payload ICD and space vehicle CONOPS
  - Analysis of the space vehicle performance, as established by BIST, showing full compliance with requirements
    - All critical resource margins should be recalculated based on actual measured values and found as adequate
    - Reliability analysis has been updated
    - All mission assurance discrepancies have been accepted for closure
    - System-level test discrepancies encountered to date (FRACAS, FRBs, and particularly UVFs) have been fully addressed
  - Description of the integrated vehicle's operating history, including trending data. Trends should be understood and support the start of environmental testing.
  - Updated system status, including:
    - Deviations from mission configuration
    - Use of placeholders and non-flight items, justification, as well as ways to ensure completion of flight configuration and verify flight item performance
    - Hardware and software liens
    - Lower-level environmental test exceedances, including justification for low risks
    - Status of flight hardware and software with respect to readiness for environmental testing
    - Status of in-progress engineering changes, operations orders, manufacturing process plan, build plans, build logs, shop orders, and other engineering documents
  - Detailed analysis of the space vehicle showing adequate margin for mechanical loads, stress, torque, thermal effects, radiation protection, and expected lifetime of limited life items
  - Finalized environment test procedures that:
    - Describe test sequences, events, operations, script, and expected results
    - Include adequate systems performance testing during and between environmental exposure so as to ensure adequate functionality
    - Provide sufficient evaluation and inspection of equipment after stress testing so as to ensure the equipment survives intact, without unexpected configuration change (which often signals subtle failure)

- Delineate combined spacecraft/payload operations including safe-to-mate, payload purging, test limits, and end-to-end testing
  - Lists all safety issues as well as mitigations
  - Describe contingency operations such as abort plans, including analyses showing that hardware will not be overstressed by associated emergency procedures
  - Explain how open liens and operational constraints are considered
  - Discuss risk mitigation approaches such as performing dry runs of the test scripts in a testbed
  - Address deviations from MIL-STD-1540E and key guidance documents related to special testing
  - Enumerate TLYF exceptions
  - Description of environmental test software and database, including:
    - Adequacy and readiness of test software
    - Data reduction software
    - Updated engineering release database
    - Test cases and manuals
    - COTS items
    - TLYF exceptions
  - Finalized report of environmental test facility and test equipment availability, including:
    - Test facility assessment including a safety analysis that evaluates possible damage (such as contamination) to flight hardware
    - Security plan including classification and Communications Security (COMSEC) considerations embodied in the test facility and test equipment
    - Test facility maintenance and inspection report
    - ICDs for electrical GSE and mechanical GSE
    - Test equipment readiness, sufficiency, calibration, maintenance, and inspection report
    - FMEA of test equipment that addresses possible damage to flight hardware
3. Equipment intended for use in a simulated space environment should be space rated (for example, a test set with cadmium-plated parts or space-incompatible cables should not be permitted in the thermal vacuum chamber to prevent contamination, multi-paction breakdown, and other problems):
- Safe-to-mate procedures including, for example, pin function map
  - Configuration of GSE
  - Metrology plan, requirements, and analysis of GSE
  - Availability of redundant instrumentation and contingency planning, including safety analysis thereof
  - Warning and maximum levels such as critical test parameter settings, monitors, yellow/redline limits, and alarms
  - ESD equipment and procedures
  - Operational manuals for the electrical GSE and mechanical GSE
  - Finalized test personnel readiness report, including:
    - Required skills, certification, and special training (e.g., ESD)
    - Operations and shift change policy
    - Availability of personnel
    - Identification of safety issues and mitigation thereof
  - Finalized test schedule and resources requirements, including:
    - Start date and task spans
    - Shifts involved
    - Post-test data evaluation, including applicable customer review



- Justification of schedule and resources based on analysis of hardware maturity and experience with programs of similar complexity
- Finalized non-conformance handling plan
  - Procedures and personnel planning to handle test discrepancies and to troubleshoot

#### 9.4 Exit Criteria

The PER is deemed successful following the completion of:

1. Successful review and approval of all documents listed above.
2. Closure (or plans and schedule to closure prior to beginning of environmental test) of all open actions and liens such as test discrepancies and conditional accept tags.

#### 9.5 Work Products

Within the PER phase, the following work products are defined and stated as follows in Table 7:

Table 7. Work Product Matrix Detail #7

<b>Critical Gated Events Work Products</b>		<b>7</b>
		<b>Pre Environmental Review (PER)</b>
<b>MISSION ASSURANCE</b>		
1	Mission Assurance Plan	<b>F</b>
2	Risk Management Plan (RMP)	<b>F</b>
3	Program Management Plan (PMP)	<b>F</b>
<b>REQUIREMENTS, ANALYSIS &amp; VALIDATION</b>		
1	Concept of Operations (CONOPS) Plan	<b>F</b>
2	System Architecture (Block Diagrams & Functional Flow Diagrams)	<b>F</b>
3	A-Specification for System Functional Baseline	<b>F</b>
4	B-Specifications for Development	<b>F</b>
5	C-Specifications for Configured Items (Units/Components/Processes)	<b>F</b>
6	Verification Cross-Reference Matrix (VCRM)	<b>F</b>
7	Technical Performance Measure (TPM) Plan	<b>F</b>
8	Interface Control Documents (Intra-ICDs) [Units/Subsystems/GSE]	<b>F</b>
9	Spacecraft to Payload ICD (Internal)	<b>F</b>
10	Spacecraft to Launch Vehicle ICD (External)	<b>F</b>
11	Spacecraft to Ground Station ICD (External)	<b>F</b>
12	Systems Engineering Management Plan (SEMP)	<b>F</b>
13	Requirements Verification Plan (RVP) [V&V Plan, VCRM]	<b>F</b>
14	Interface Verification Plan (IVP)	<b>R</b>
15	Analysis & Simulation Plan (ASP)	<b>F</b>

<b>Critical Gated Events Work Products</b>		<b>7</b>
		<b>Pre Environmental Review (PER)</b>
16	Algorithm Development Plan (ADP)	R
17	Error Budgets & Allocation Analysis	F
18	Post Delivery Support Plan (PDSP)	F
19	Technology Insertion Plan (TIP)	F
20	Analysis Verification Reports	R
21	Inspection Verification Reports	R
22	Demonstration Verification Reports	R
<b>RELIABILITY ENGINEERING</b>		
1	Reliability, Availability, Maintainability Plan (RAMP)	R
2	Reliability Analyses (Failure Prediction, FMEA, FMECA, SPF, etc.)	R
3	Critical Items List & Limited Life List	F
4	FRACAS/FRB Plan	F
<b>PARTS, MATERIALS &amp; PROCESSES (PMP) ENGINEERING</b>		
1	Parts, Material & Process (PMP) Plan	F
2	Approved Parts, Materials & Processes List (APMPL)	F
3	Major Subcontracts Plan (MSP or SCM Plan)	F
4	Contamination Control Plan (CCP)	F
<b>CONFIGURATION MANAGEMENT</b>		
1	Configuration Management Plan (CMP)	F
2	Data Management Plan (DMP)	F
<b>QUALITY ASSURANCE</b>		
1	Product Assurance Plan	F
<b>SYSTEM SAFETY ASSURANCE</b>		
1	SSHP (System Safety & Hazard Plan) [includes Human Factors]	F
2	Environmental Effects Plan (EEP) [EMI/EMC Plan, Radiation Effects, etc.]	F
3	Electro Static Discharge Plan (ESDP) [includes Spacecraft Charging, Power Distribution & Grounding]	F
<b>DESIGN ASSURANCE</b>		
1	Hardware Development Plan (HDP)	F
2	Detail Drawings	F
3	Assembly Drawings	F
4	Installation Drawings/Procedures	F
5	Schematics/Wiring Diagrams	F
6	Worst-Case Design Analyses	F
7	STOP Analyses (Structural, Thermal, Optical, Performance)	F

<b>Critical Gated Events Work Products</b>		<b>7</b>
		<b>Pre Environmental Review (PER)</b>
8	Packaging, Handling, Storage & Transportation (PHST) Plan	F
<b>SOFTWARE ASSURANCE</b>		
1	Software Development Plan (SDP)	F
2	Software Requirements Specification	F
3	Software Manuals	F
<b>MANUFACTURING ASSURANCE</b>		
1	Manufacturing Operating Plan (MOP)	F
2	Producibility Plan	F
3	Production Plan & Master Production Schedule (Capacity & Throughput Analysis)	F
4	Build History Planning/Work Orders	F
5	Kitting & Parts Status Plan	F
6	Facilities/Space Plan (FSP)	F
7	Manufacturing Facility Certification	F
8	Skills Training & Certification Matrix	R
9	GSE/STE/Tooling Certified/Calibrated/Proof-Loaded/PM Matrix	R
<b>INTEGRATION, TEST &amp; EVALUATION</b>		
1	Test Requirements Specification (TRS)	F
2	Environmental Test Requirements Specification (ETRS)	F
3	GSE/STE ICD (Mech/Elect/Optical/Thermal)	F
4	Embedded Test (BIT)/Integrated Diagnostics/DFT Requirements	F
5	GSE/STE Analysis, FMEA	F
6	GSE/STE Metrology Plan	F
7	Test & Evaluation Master Plan (TEMP) [includes Design-for-Test; BIT Testing]	F
8	Top-Level Test Configuration Drawing	F
9	Thermal Vacuum Test Plan	F
10	EMI/EMC Test Plan	F
11	Vibration, Shock & Acoustics Test Plan	F
12	Mass Properties Test Plan	F
13	Test Scripts/Recipes	F
14	Test Procedures – Electrical (Functional)	F
15	Test Procedures – RF	F
16	Test Procedures – Optical	F
17	Test Procedures – Thermal Vacuum	F
18	Test Procedures – Thermal Balance	F
19	Test Procedures – Vibration/Shock	F

Critical Gated Events Work Products		7
		Pre Environmental Review (PER)
20	Test Procedures – Acoustic	F
21	Test Procedures – Mass Properties	F
22	Test Lab Certification	F
23	Test Verification Reports	R
24	User Guides/Test Manuals	R
<b>OPERATIONAL READINESS ASSURANCE</b>		
1	Pre-Launch DD-250	
2	Flight Worthiness Certification by Launch Authority	
3	Aerospace Launch Verification Letter	
4	Early On-Orbit Testing (EOT) Report	
5	SCA Change Notice	

**C = Created:** The initial generation or first draft of a work product being developed that is under author control and has not been reviewed.

**U = Updated:** A work product that contains new information, remains under author or IPT control, and has completed an informal review process by peers.

**B = Baselined:** A prepared or concluded work product that has been iterated, has IPT or program management acceptance, is ready for a formal gated event review, and may not be changed without formal CM revision control.

**R = Revised:** A reevaluated work product that has been significantly modified, remains under CM control, and will require approval authority for changes to the technical baseline.

**F = Finalized:** Brings a work product to its final state where it has been reviewed and/or signed off by the approval authority and is available for use.

## 9.6 References

- |                                       |   |
|---------------------------------------|---|
| Aerospace TOR-2004(3909)-3360, Rev. 1 | <i>System Engineer's Major Reviews for National Security Space System Programs</i> ,<br>T. Hoang,<br>2 February 2005        |
| Aerospace TOR-2006(8506)-4494         | <i>Space Vehicle Test and Evaluation Handbook</i> ,<br>Edited by W. Englehart,<br>30 November 2005                          |
| Aerospace TOR-2006(8546)-4591         | <i>Space Vehicle Test and Evaluation Handbook</i> ,<br>Edited by D. Hanifen, A. Peterson, and W. Tosney,<br>6 November 2006 |
| Aerospace TOR-2005(3901)-3797         | <i>Verification Requirements for Space Vehicles</i> ,<br>S. Nagano,<br>15 December 2005                                     |
| Aerospace TOR-2004(3901)-3242         | <i>General Guideline for Space Vehicle Verification Plan Development and Execution</i> ,<br>S. Nagano,<br>15 March 2004     |

SMC-TR-06-11	<i>Test Requirements for Launch, Upper-Stage, and Space Vehicles,</i> TBS, 6 September 2006
MIL- HDBK- 340A	<i>Test Requirements for Launch, Upper-Stage, and Space Vehicles,</i> Department of Defense - USAF, 1 April 1999
NASA GSFC-STD-1001	<i>Criteria for Flight Project Critical Milestone Reviews,</i> Approved by R. Day, 19 February 2005
ECSS-E-10-03A	<i>Testing,</i> European Cooperation for Space Standardization, 15 February 2002
ECSS-E-10-02A	<i>Verification,</i> European Cooperation for Space Standardization, 17 November 1998



## 10. Gate 8: Pre-Ship Review (PSR)

### 10.1 Introduction

The program conducts a hardware PSR to assure that flight hardware and components, software, GSE, and procedural documentation are ready to ship to the deployment site. Operations personnel participate in this review. This type of review is meant to identify any open issues affecting deployment and subsequent operations, verify that planning is in place to close-out these issues in a timely manner, and verify supportability of the program's ensuing activities. Operations personnel ensure sufficient coordination between the system contractor and Range/launch site (and/or any other receiving site), to assure that the latter is ready to receive program hardware, receiving support has been appropriately scheduled, and receiving facilities are prepared to support hardware arrival and post-shipping inspection activities.

The objectives of the PSR are to demonstrate that: 1) all functional performance and environmental testing of the flight system has been successfully completed, 2) all discrepancies are fully understood and satisfactorily resolved, including completion of corrective actions as well as planning and preparation of any required follow-on actions, 3) planning and preparation for shipping and subsequent ground processing, launch, and mission operations is complete, and 4) network and ground systems are compatible for testing as well as mission simulations. The following information is typically reviewed and delivered as part of PSR:

- Complete build history book summary of serialized items (starting at the lowest level of assembly)
- Records reflecting traceability of parts, materials, and subassemblies installed
- AD/AB configuration control summary and delta report
- Assembly removal and replacement/installation list
- Deviation/waiver variance summary
- Open lien summary of nonconformances
- Total lien list/MRB actions
- Total test failure/anomaly summary/FRB actions
- Watch list, unverified failure (UVF), TLYF exception, and out-of-family conditions summary
- Individual RVRs
- VCRM summary
- TPM summary
- Acceptance test sequence
- Acceptance test performance summary
- Test history, including environmental exposure summary
- Identification of associated test equipment and test software
- Temperature sensor calibration data
- Operating time/number of cycles test summary (accumulative vibration and temperature exposure)
- Storage history
- Product photographs
- User guides/operations manuals/CONOPS documents
- Prior major review action items and open/significant issues list
- Mission assurance audit summary
- DD250/DD1149 paperwork

## 10.2 Purpose

The purpose of the PSR is to demonstrate that the flight system is ready for shipment to the launch site and for final processing prior to launch and mission operations. To that end, the project demonstrates that all performance and environmental verification activities of the integrated flight system have been successfully completed, that all ground system verification and compatibility testing has been successfully completed, and that open/known discrepancies of any type have been satisfactorily resolved.

## 10.3 Entrance Criteria

1. All major issues generated in previous major reviews/gates have been worked to closure, and for open issues a corrective action plan with detailed implementation steps has been developed and approved.
2. System-level hardware and software test data has been reviewed, meets acceptance criteria for all modes and states, and the system-level test configuration has been granted approval for “consent to break” since all test and verification objectives have been met.
3. The VCRM has been “scrubbed” and the system-level performance requirements are traceable, measurable, and achieve the required performance requirements/TPMs. RVRs have been submitted for review and have been approved.
4. Functional performance had been validated and physical configuration has been verified through a series of functional and physical configuration audits (FCAs/PCAs) and pedigree reviews.

## 10.4 Exit Criteria

1. An end item data package has been compiled and reflects all the information listed above (under “information reviewed at a PSR”) as a deliverable item. All documentation has been reviewed, “dispositioned,” and closed in preparation for DD250 completion.
2. An operational requirements document (ORD) has been completed.
3. Analysis of interfaces between units (inter/intra-subsystem, inter-segment, and inter-system) has been completed.
4. Segment requirements have been evaluated, allocated, and revised as a result of completion of all spacecraft testing activities.
5. User guides, operations manuals, and CONOPS documents are revised one final time prior to shipment – incorporating the final testing lessons learned.
6. Failure modes effects and criticality analysis (FMECA) is complete and verified.
7. Hazards identification and analysis of system hardware and software, the system environment, and its intended use is completed.
8. Mishap risk assessments have been completed to define severity and probability of each identified hazard on personnel, facilities, equipment, operations, the public, the environment, and the system itself.
9. Compliance with ground operations safety requirements is verified.
10. Material handling equipment (MHE) used to handle critical flight hardware is single fault tolerant.
11. Equipment (including test equipment, tooling, and GSE) that will be used at the launch site is certified, calibrated, and proof-loaded prior to shipment – and is compliant with Range Safety requirements (i.e., EWR 127-1 or AFSPC Manual 91-710).
12. A packaging, handling, storage, and transportation (PHST) plan is revised as required, prior to spacecraft shipment to the launch site.



13. Shipping containers have been prepared, and all ancillary hardware has been inventoried and is in place. Flight hardware/spacecraft has been properly stored and is ready for delivery to the launch site.
14. Customer-owned and government furnished equipment (GFE) is identified prior to shipment to the launch site.
15. Program risk burn-down and mitigation/recovery plans are considered credible and agreed upon by stakeholders.
16. Customer concurrence that all controls are in-place for shipment of spacecraft to the launch site is obtained.

## 10.5 Work Products

Within the PER phase, the following work products are defined and stated as follows in Table 8:

Table 8. Work Product Matrix Detail #8

<b>Critical Gated Events Work Products</b>		<b>8</b>
		<b>Pre Ship Review (PSR)</b>
<b><i>MISSION ASSURANCE</i></b>		
1	Mission Assurance Plan	<b>F</b>
2	Risk Management Plan (RMP)	<b>F</b>
3	Program Management Plan (PMP)	<b>F</b>
<b><i>REQUIREMENTS, ANALYSIS &amp; VALIDATION</i></b>		
1	Concept of Operations (CONOPS) Plan	<b>F</b>
2	System Architecture (Block Diagrams & Functional Flow Diagrams)	<b>F</b>
3	A-Specification for System Functional Baseline	<b>F</b>
4	B-Specifications for Development	<b>F</b>
5	C-Specifications for Configured Items (Units/Components/Processes)	<b>F</b>
6	Verification Cross-Reference Matrix (VCRM)	<b>F</b>
7	Technical Performance Measure (TPM) Plan	<b>F</b>
8	Interface Control Documents (Intra-ICDs) [Units/Subsystems/GSE]	<b>F</b>
9	Spacecraft to Payload ICD (Internal)	<b>F</b>
10	Spacecraft to Launch Vehicle ICD (External)	<b>F</b>
11	Spacecraft to Ground Station ICD (External)	<b>F</b>
12	Systems Engineering Management Plan (SEMP)	<b>F</b>
13	Requirements Verification Plan (RVP) [V&V Plan, VCRM]	<b>F</b>
14	Interface Verification Plan (IVP)	<b>F</b>
15	Analysis & Simulation Plan (ASP)	<b>F</b>
16	Algorithm Development Plan (ADP)	<b>F</b>
17	Error Budgets & Allocation Analysis	<b>F</b>
18	Post Delivery Support Plan (PDSP)	<b>F</b>
19	Technology Insertion Plan (TIP)	<b>F</b>

<b>Critical Gated Events Work Products</b>		<b>8</b>
		<b>Pre Ship Review (PSR)</b>
20	Analysis Verification Reports	<b>F</b>
21	Inspection Verification Reports	<b>F</b>
22	Demonstration Verification Reports	<b>F</b>
<b>RELIABILITY ENGINEERING</b>		
1	Reliability, Availability, Maintainability Plan (RAMP)	<b>F</b>
2	Reliability Analyses (Failure Prediction, FMEA, FMECA, SPF, etc.)	<b>F</b>
3	Critical Items List & Limited Life List	<b>F</b>
4	FRACAS/FRB Plan	<b>F</b>
<b>PARTS, MATERIALS &amp; PROCESSES (PMP) ENGINEERING</b>		
1	Parts, Material & Process (PMP) Plan	<b>F</b>
2	Approved Parts, Materials & Processes List (APMPL)	<b>F</b>
3	Major Subcontracts Plan (MSP or SCM Plan)	<b>F</b>
4	Contamination Control Plan (CCP)	<b>F</b>
<b>CONFIGURATION MANAGEMENT</b>		
1	Configuration Management Plan (CMP)	<b>F</b>
2	Data Management Plan (DMP)	<b>F</b>
<b>QUALITY ASSURANCE</b>		
1	Product Assurance Plan	<b>F</b>
<b>SYSTEM SAFETY ASSURANCE</b>		
1	SSHP (System Safety & Hazard Plan) [includes Human Factors]	<b>F</b>
2	Environmental Effects Plan (EEP) [EMI/EMC Plan, Radiation Effects, etc.]	<b>F</b>
3	Electro Static Discharge Plan (ESDP) [includes Spacecraft Charging, Power Distribution & Grounding]	<b>F</b>
<b>DESIGN ASSURANCE</b>		
1	Hardware Development Plan (HDP)	<b>F</b>
2	Detail Drawings	<b>F</b>
3	Assembly Drawings	<b>F</b>
4	Installation Drawings/Procedures	<b>F</b>
5	Schematics/Wiring Diagrams	<b>F</b>
6	Worst-Case Design Analyses	<b>F</b>
7	Structural, Thermal, Optical, Performance (STOP) Analyses	<b>F</b>
8	Packaging, Handling, Storage & Transportation (PHST) Plan	<b>F</b>
<b>SOFTWARE ASSURANCE</b>		
1	Software Development Plan (SDP)	<b>F</b>

<b>Critical Gated Events Work Products</b>		<b>8</b>
		<b>Pre Ship Review (PSR)</b>
2	Software Requirements Specification	<b>F</b>
3	Software Manuals	<b>F</b>
<b>MANUFACTURING ASSURANCE</b>		
1	Manufacturing Operating Plan (MOP)	<b>F</b>
2	Producibility Plan	<b>F</b>
3	Production Plan & Master Production Schedule (Capacity & Throughput Analysis)	<b>F</b>
4	Build History Planning/Work Orders	<b>F</b>
5	Kitting & Parts Status Plan	<b>F</b>
6	Facilities/Space Plan (FSP)	<b>F</b>
7	Manufacturing Facility Certification	<b>F</b>
8	Skills Training & Certification Matrix	<b>F</b>
9	GSE/STE/Tooling Certified/Calibrated/Proof-Loaded/PM Matrix	<b>F</b>
<b>INTEGRATION, TEST &amp; EVALUATION</b>		
1	Test Requirements Specification (TRS)	<b>F</b>
2	Environmental Test Requirements Specification (ETRS)	<b>F</b>
3	GSE/STE ICD (Mech/Elect/Optical/Thermal)	<b>F</b>
4	Embedded Test (BIT)/Integrated Diagnostics/ DFT Requirements	<b>F</b>
5	GSE/STE Analysis, FMEA	<b>F</b>
6	GSE/STE Metrology Plan	<b>F</b>
7	Test & Evaluation Master Plan (TEMP) [includes Design-for-Test; BIT Testing]	<b>F</b>
8	Top-Level Test Configuration Drawing	<b>F</b>
9	Thermal Vacuum Test Plan	<b>F</b>
10	EMI/EMC Test Plan	<b>F</b>
11	Vibration, Shock & Acoustics Test Plan	<b>F</b>
12	Mass Properties Test Plan	<b>F</b>
13	Test Scripts/Recipes	<b>F</b>
14	Test Procedures – Electrical (Functional)	<b>F</b>
15	Test Procedures – RF	<b>F</b>
16	Test Procedures – Optical	<b>F</b>
17	Test Procedures – Thermal Vacuum	<b>F</b>
18	Test Procedures – Thermal Balance	<b>F</b>
19	Test Procedures – Vibration/Shock	<b>F</b>
20	Test Procedures – Acoustic	<b>F</b>
21	Test Procedures – Mass Properties	<b>F</b>
22	Test Lab Certification	<b>F</b>
23	Test Verification Reports	<b>F</b>
24	User Guides/Test Manuals	<b>F</b>

<b>Critical Gated Events Work Products</b>		<b>8</b>
		<b>Pre Ship Review (PSR)</b>
<b>OPERATIONAL READINESS ASSURANCE</b>		
1	Pre-Launch DD-250	<b>C</b>
2	Flight Worthiness Certification by Launch Authority	
3	Aerospace Launch Verification Letter	
4	Early On-Orbit Testing (EOT) Report	
5	SCA Change Notice	

**C = Created:** The initial generation or first draft of a work product being developed that is under author control and has not been reviewed.

**U = Updated:** A work product that contains new information, remains under author or IPT control, and has completed an informal review process by peers.

**B = Baseline:** A prepared or concluded work product that has been iterated, has IPT or program management acceptance, is ready for a formal gated event review, and may not be changed without formal CM revision control.

**R = Revised:** A reevaluated work product that has been significantly modified, remains under CM control, and will require approval authority for changes to the technical baseline.

**F = Finalized:** Brings a work product to its final state where it has been reviewed and/or signed off by the approval authority and is available for use.

## 10.6 References

- |                                    |  |
|------------------------------------|--|
| Aerospace TOR-2007(8546)-6018      | <i>Mission Assurance Guide</i> ,<br>Edited by S. Guarro and W. Tosney,<br>1 July 2007  |
| Aerospace TOR-2006(8546)-4591      | <i>Space Vehicle Test and Evaluation Handbook</i> ,<br>Edited by D. Hanifen, A. Peterson, and W. Tosney,<br>6 November 2006        |
| Aerospace TOR-2006(8506)-4494      | <i>Space Vehicle Systems Engineering Handbook</i> ,<br>Edited by W. Englehart,<br>30 November 2005                                 |
| INCOSE-TP-2003-0126-02, Version 2a | <i>Systems Engineering Handbook</i> ,<br>International Council on Systems Engineering (INCOSE),<br>Technical Staff,<br>1 June 2004 |
| Defense Acquisition University     | <i>DAU Systems Engineering Fundamentals</i> ,<br>Defense Acquisition University Press,<br>1 January 2001                           |

NASA GSFC-STD-1001	<i>Criteria for Flight Project Critical Milestone Reviews,</i> Approved by R. Day, 19 February 2005
NASA SP-6105	<i>NASA Systems Engineering Handbook,</i> R. Shishko, Ph.D., 1 June 1995
SMCI 63-1201	<i>Assurance of Operational Safety, Suitability, &amp; Effectiveness for Space and Missile Systems,</i> Lt. Colonel George Newberry and Certified by Colonel James Horejsi, 16 January 2004
SMCI 63-1202	<i>Space Flight Worthiness,</i> David Davis and Certified by Colonel James Horejsi, 16 January 2004
SMCI 63-1203	<i>Independent Readiness Review Teams,</i> Lt. Colonel William Harding and Certified by Colonel James Horejsi, 16 January 2004
SMCI 63-1204	<i>Readiness Review Process,</i> Captain d'Artagnan de Anda and Certified by Colonel Ivette Falto-Heck, 1 August 2002

## **11. Gate 9: Mission Readiness Review (MRR)**

### **11.1 Objective**

The MRR is the final formal review prior to committing to erect the launch vehicle and mate the space vehicle. At this point, the space vehicle and all major segments of the launch vehicle have completed their respective PSR gate processes. Once the vehicle has been erected, integrated system checkout operations are conducted to 1) verify no damage has been sustained during transit and/or installation, 2) validate prior major component/system-level checkout results, 3) verify integrated system operations, and 4) verify ground to launch vehicle, and space vehicle telemetry and communications.

The outcome of this review is Authority to Proceed to vehicle stacking, space vehicle mating, and subsequent checkout operations.

### **11.2 Entrance Criteria:**

1. Separate mission segments have satisfactorily completed their respective verification and training operations.
2. All segment-level and lower-level discrepancies have been addressed, dispositioned, documented, and any open items recorded.
3. Documented plans and risk assessments exist for addressing and mitigating open issues carried forward from segment and lower-level processing operations.
4. Hardware shortages have been identified with plans for final integration.
5. Independent readiness reviews of the individual mission segments (e.g., payload and bus, ground station, launch vehicle) have been completed and open actions and minority dissenting opinions addressed at the appropriate segment level.
6. Independent readiness review findings and dispositions from all segments have been collected and are available for review.
7. Final launch vehicle and space vehicle processing requirements documents have been released.
8. Hardware move plans and processing procedures have been finalized and released.
9. All required resources and equipment are identified and certified as “ready to support” segment integration and test operations.
10. Segment integration personnel have completed safety and required operations training, and personnel certifications are up to date.
11. Segment integration and test facilities are available, certified, and ready to support processing.
12. Local site system safety engineering and hazard management requirements and procedures are compliant with local and contractor specifications.
13. Relevant hazards to mission personnel and public, the launch vehicle and spacecraft, and launch facilities have been reviewed and appropriate contingencies developed and released.
14. Flight hardware and GSE/STE have been received at the launch site.
15. Range Safety plan revisions have been released and provided to the Range manager.
16. Hardware pedigree reviews have been completed and findings dispositioned.
17. Launch site configuration audits are complete.
18. A security plan has been released that includes classification and COMSEC considerations covering the test facility, test equipment, and flight hardware.
19. Test facility maintenance and inspection reports are current and available.

### **11.3 Exit Criteria**

Successful completion of MRR generally includes consideration of the following items:

1. GSE, launch vehicle, and launch support assets have been identified and low-risk workaround plans presented and approved for non-compliant items.
2. Range Safety plan has been discussed with and approved by the Range manager.
3. Launch site requirements have been discussed and approved.
  - a. Launch site and supporting infrastructure
    - i. Launch pad
      1. Hardware transport equipment
      2. Hardware lifting/hoisting equipment
      3. Weather protection systems and equipment
      4. Laser alignment
      5. Hazardous operations
      6. Portable and stationary environment control systems (A/C, heating, humidity control, etc.)
      7. Telemetry systems
    - ii. Infrastructure
      1. Launch vehicle and space vehicle processing buildings
      2. Auxiliary electrical systems
      3. Cryogenic liquids
      4. Gases
      5. Hydraulics
      6. Clean rooms
      7. Portable and stationary environment control systems (A/C, heating, humidity control, etc.)
      8. Vehicle tracking assets (airborne and ground) used for system integration testing, validation, and telemetry check-outs
  - b. Waivers, non-conformances, deviations, and failure analysis reports have been presented and approved.
4. Updated flight hardware configuration and assignments records, which include post-PSR field modifications, are approved and released.
5. Launch site configuration audits have been approved.
  - a. Launch pad and supporting infrastructure
  - b. Mission directors center (MDC)
  - c. Launch vehicle data center (LVDC)
6. An emergency contingency plan has been approved and is compliant with Range Safety (EWR 127-1 or AFSPC Manual 91-710), local, and OSHA requirements.
7. A go-forward risk assessment plan has been approved.
8. Anomaly and failure analysis closure status and plans have been reviewed and approved (directly related to the mission hardware and/or other mission hardware implicating the mission).
  - a. Repeatable and non-repeatable failures
  - b. Closed failure analysis (FA)/corrective action (CA) approved
  - c. Open FA/CA risk assessment completed
9. Industry-, contractor-, and government-issued alerts have been reviewed and impact assessed, dispositioned and closed.
10. Final assessment and disposition by launch vehicle, space vehicle and launch site (*Go or No Go*), involving:
  - a. Program managers
  - b. Mission assurance managers
  - c. Chief engineers
  - d. Mission integration managers
  - e. Mission-specific disciplines (as required)

11. Processing schedules have been approved.
12. A program launch-site security plan has been approved.

#### 11.4 Work Products

Within the PER phase, the following work products are defined and stated as follows in Table 9:

Table 9. Work Product Matrix Detail #9

<b>Critical Gated Events Work Products</b>		<b>9</b>
		<b>Mission Readiness Review (MRR)</b>
<b>MISSION ASSURANCE</b>		
1	Mission Assurance Plan	<b>F</b>
2	Risk Management Plan (RMP)	<b>F</b>
3	Program Management Plan (PMP)	<b>F</b>
<b>REQUIREMENTS, ANALYSIS &amp; VALIDATION</b>		
1	Concept of Operations (CONOPS) Plan	<b>F</b>
2	System Architecture (Block Diagrams & Functional Flow Diagrams)	<b>F</b>
3	A-Specification for System Functional Baseline	<b>F</b>
4	B-Specifications for Development	<b>F</b>
5	C-Specifications for Configured Items (Units/Components/Processes)	<b>F</b>
6	Verification Cross-Reference Matrix (VCRM)	<b>F</b>
7	Technical Performance Measure (TPM) Plan	<b>F</b>
8	Interface Control Documents (Intra-ICDs) [Units/Subsystems/GSE]	<b>F</b>
9	Spacecraft to Payload ICD (Internal)	<b>F</b>
10	Spacecraft to Launch Vehicle ICD (External)	<b>F</b>
11	Spacecraft to Ground Station ICD (External)	<b>F</b>
12	Systems Engineering Management Plan (SEMP)	<b>F</b>
13	Requirements Verification Plan (RVP) [V&V Plan, VCRM]	<b>F</b>
14	Interface Verification Plan (IVP)	<b>F</b>
15	Analysis & Simulation Plan (ASP)	<b>F</b>
16	Algorithm Development Plan (ADP)	<b>F</b>
17	Error Budgets & Allocation Analysis	<b>F</b>
18	Post Delivery Support Plan (PDSP)	<b>F</b>
19	Technology Insertion Plan (TIP)	<b>F</b>
20	Analysis Verification Reports	<b>F</b>
21	Inspection Verification Reports	<b>F</b>
22	Demonstration Verification Reports	<b>F</b>



<b>Critical Gated Events Work Products</b>		<b>9</b>
		<b>Mission Readiness Review (MRR)</b>
<b>RELIABILITY ENGINEERING</b>		
1	Reliability, Availability, Maintainability Plan (RAMP)	<b>F</b>
2	Reliability Analyses (Failure Prediction, FMEA, FMECA, SPF, etc.)	<b>F</b>
3	Critical Items List & Limited Life List	<b>F</b>
4	FRACAS/FRB Plan	<b>F</b>
<b>PARTS, MATERIALS &amp; PROCESSES (PMP) ENGINEERING</b>		
1	Parts, Material & Process (PMP) Plan	<b>F</b>
2	Approved Parts, Materials & Processes List (APMPL)	<b>F</b>
3	Major Subcontracts Plan (MSP or SCM Plan)	<b>F</b>
4	Contamination Control Plan (CCP)	<b>F</b>
<b>CONFIGURATION MANAGEMENT</b>		
1	Configuration Management Plan (CMP)	<b>F</b>
2	Data Management Plan (DMP)	<b>F</b>
<b>QUALITY ASSURANCE</b>		
1	Product Assurance Plan	<b>F</b>
<b>SYSTEM SAFETY ASSURANCE</b>		
1	SSHP (System Safety & Hazard Plan) [includes Human Factors]	<b>F</b>
2	Environmental Effects Plan (EEP) [EMI/EMC Plan, Radiation Effects, etc.]	<b>F</b>
3	Electro Static Discharge Plan (ESDP) [includes Spacecraft Charging, Power Distribution & Grounding]	<b>F</b>
<b>DESIGN ASSURANCE</b>		
1	Hardware Development Plan (HDP)	<b>F</b>
2	Detail Drawings	<b>F</b>
3	Assembly Drawings	<b>F</b>
4	Installation Drawings/Procedures	<b>F</b>
5	Schematics/Wiring Diagrams	<b>F</b>
6	Worst-Case Design Analyses	<b>F</b>
7	Structural, Thermal, Optical, Performance (STOP) Analyses	<b>F</b>
8	Packaging, Handling, Storage & Transportation (PHST) Plan	<b>F</b>
<b>SOFTWARE ASSURANCE</b>		
1	Software Development Plan (SDP)	<b>F</b>
2	Software Requirements Specification	<b>F</b>
3	Software Manuals	<b>F</b>

<b>Critical Gated Events Work Products</b>		<b>9</b>
		<b>Mission Readiness Review (MRR)</b>
<b>MANUFACTURING ASSURANCE</b>		
1	Manufacturing Operating Plan (MOP)	<b>F</b>
2	Producibility Plan	<b>F</b>
3	Production Plan & Master Production Schedule (Capacity & Throughput Analysis)	<b>F</b>
4	Build History Planning/Work Orders	<b>F</b>
5	Kitting & Parts Status Plan	<b>F</b>
6	Facilities/Space Plan (FSP)	<b>F</b>
7	Manufacturing Facility Certification	<b>F</b>
8	Skills Training & Certification Matrix	<b>F</b>
9	GSE/STE/Tooling Certified/Calibrated/Proof-Loaded/PM Matrix	<b>F</b>
<b>INTEGRATION, TEST &amp; EVALUATION</b>		
1	Test Requirements Specification (TRS)	<b>F</b>
2	Environmental Test Requirements Specification (ETRS)	<b>F</b>
3	GSE/STE ICD (Mech/Elect/Optical/Thermal)	<b>F</b>
4	Embedded Test (BIT)/Integrated Diagnostics/ DFT Requirements	<b>F</b>
5	GSE/STE Analysis, FMEA	<b>F</b>
6	GSE/STE Metrology Plan	<b>F</b>
7	Test & Evaluation Master Plan (TEMP) [includes Design-for-Test; BIT Testing]	<b>F</b>
8	Top-Level Test Configuration Drawing	<b>F</b>
9	Thermal Vacuum Test Plan	<b>F</b>
10	EMI/EMC Test Plan	<b>F</b>
11	Vibration, Shock & Acoustics Test Plan	<b>F</b>
12	Mass Properties Test Plan	<b>F</b>
13	Test Scripts/Recipes	<b>F</b>
14	Test Procedures – Electrical (Functional)	<b>F</b>
15	Test Procedures – RF	<b>F</b>
16	Test Procedures – Optical	<b>F</b>
17	Test Procedures – Thermal Vacuum	<b>F</b>
18	Test Procedures – Thermal Balance	<b>F</b>
19	Test Procedures – Vibration/Shock	<b>F</b>
20	Test Procedures – Acoustic	<b>F</b>
21	Test Procedures – Mass Properties	<b>F</b>
22	Test Lab Certification	<b>F</b>
23	Test Verification Reports	<b>F</b>
24	User Guides/Test Manuals	<b>F</b>

<b>Critical Gated Events Work Products</b>		<b>9</b>
		<b>Mission Readiness Review (MRR)</b>
<b>OPERATIONAL READINESS ASSURANCE</b>		
1	Pre-Launch DD-250	<b>B</b>
2	Flight Worthiness Certification by Launch Authority	
3	Aerospace Launch Verification Letter	
4	Early On-Orbit Testing (EOT) Report	
5	SCA Change Notice	

**C = Created:** The initial generation or first draft of a work product being developed that is under author control and has not been reviewed.

**U = Updated:** A work product that contains new information, remains under author or IPT control, and has completed an informal review process by peers.

**B = Baselined:** A prepared or concluded work product that has been iterated, has IPT or program management acceptance, is ready for a formal gated event review, and may not be changed without formal CM revision control.

**R = Revised:** A reevaluated work product that has been significantly modified, remains under CM control, and will require approval authority for changes to the technical baseline.

**F = Finalized:** Brings a work product to its final state where it has been reviewed and/or signed off by the approval authority and is available for use.

## 11.5 References

Defense Technical Information Center Guide #ADA223168 *Systems Engineering Management Guide*, January 1990, Defense Systems Management College, Fort Belvoir, VA

## 12. Gate 10: Flight Readiness Review (FRR)

### 12.1 Introduction

Following successful consent-to-ship review (formally known as the mission readiness review), the satellite is brought to the launch site, encapsulated, mated to the launch vehicle, and launched (Figure 13).

As enumerated in Table 10 [Reference 1], multiple tasks are executed along the way by four types of organizations: Space Vehicle, Launch Vehicle, Space Lift, and Satellite Operations. Elaborate reviews are conducted in between, including the launch site readiness review, Aerospace President’s review, operational readiness review, flight readiness review, and launch readiness review. The objectives of these reviews are summarized below.

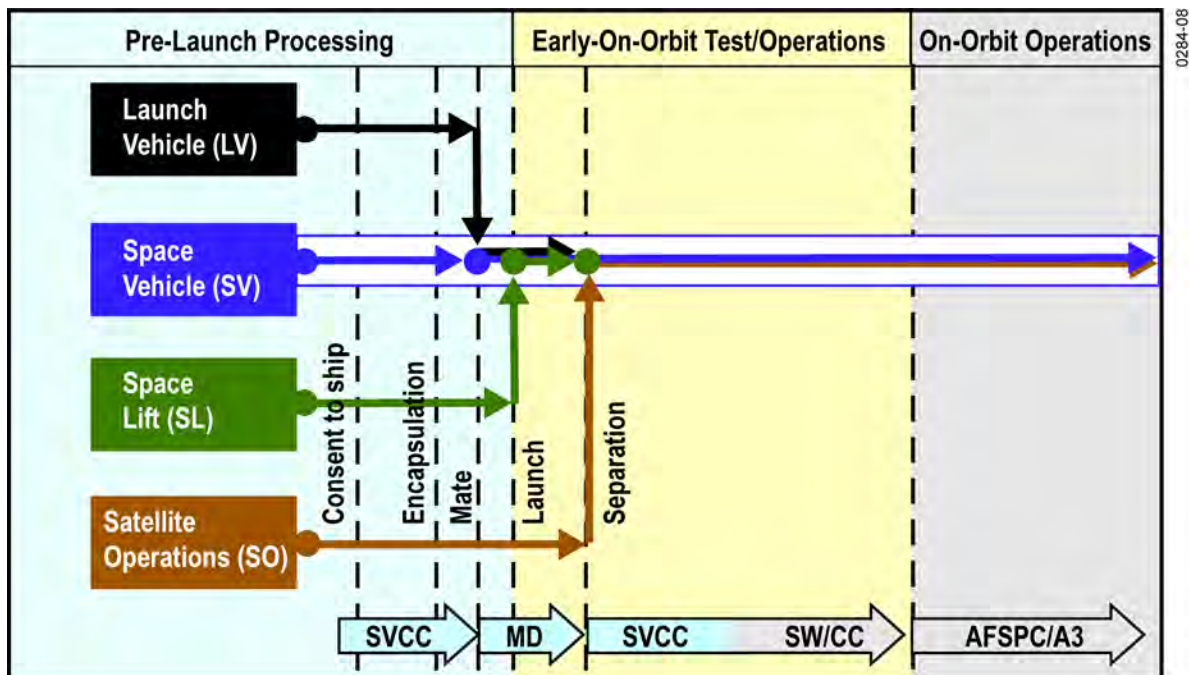

Source: Adapted from Reference 1

Note: Tasks assigned to Space Lift are usually performed by the 14th AF (45th SW at Patrick Air Force Base or 30th SW at Vandenberg Air Force Base).

Figure 13. Satellite Workflow from Consent-to-Ship to On-orbit Operations

### 12.2 Purpose

Collectively, the FRR evaluates the system’s space flight worthiness, including the readiness of launch and support facilities (ground systems), Range and orbital operations, the readiness and training of the operating personnel, and the safety of the integrated system. For this document, the FRR’s main objective is to ascertain the space vehicle’s flight worthiness. Discussion of the procedures used by other organizations, such as the launch verification matrix, is outside the scope of this document.

Table 10. Baseline Tasks for Nominal Satellite Processing from Factory to Operations

<b>ID</b>	<b>Task</b>	<b>Primary Responsibility</b>
1.	Factory Confidence Test (FCT), Leak Test	SV
2.	Satellite Control Network Integration Test	SV
3.	Final Shipping Preparations/Margin	SV
4.	Mission Readiness Review (MRR)	SV
5.	Consent-to-Ship	SV
6.	Transport Satellite to Launch Site	SV
7.	Satellite Processing at Payload Facility	SV
8.	Receive and Inspect	SV
9.	Launch Base Compatibility Test	SV
10.	Command Control Test	SV
11.	Satellite-to-Adaptor Mate	SV
12.	Satellite Functional Testing	SV
13.	Final Weight and Balance	SV
14.	Intersegment Verification Testing	SV
15.	Consent-to-Fuel	SV
16.	Payload Encapsulation	SV
17.	Launch Site Readiness Review (LSRR)	LS
18.	Consent-to-Mate Satellite to Launch Vehicle	LV
19.	Satellite Transport to Pad	LV
20.	On-Pad Processing	LV, SV
21.	Initial Satellite-to-Launch Vehicle Systems Tests	LV, SV
22.	Satellite/Launch Vehicle Procedure Reviews and Table Tops	LV, SV
23.	Support Equipment Test and Checkout	LV, SV
24.	Satellite Hoist and Mate Operations	LV, SV
25.	Satellite/Launch Vehicle Stack Systems-Level Tests	LV, SV
26.	Payload Fairing Closeout Operations	LV, SV
27.	Aerospace President's Review (APR)	Aerospace
28.	Mission Dress Rehearsal(s)/Integrated Crew Exercises	SV or LV or SL or SO*
29.	Operational Readiness Review(s) (ORR)	SO
30.	Flight Readiness Review (FRR)	SMC/EA
31.	Launch Readiness Review (LRR)	LV, SV, SL, SO
32.	Day of Launch (DoL)	SL
33.	Logistics and Admin Update	SL
34.	Weather Forecast and Winds Aloft Updates	SL
35.	Polls	MD
36.	Mission Is Go/No Go	LV, SV
37.	Final Clear to Launch	MD, SO, SL
38.	Countdown, Sequence of Events (SOE)	SL
39.	Launch	LV
40.	Satellite Separation	LV
41.	Satellite Separation Report	LV
42.	Satellite Control Authority (SCA) Transfer to Early On-Orbit Test (EOT)/Operations	

ID	Task	Primary Responsibility
43.	Early On-Orbit Test	SO or SV **
44.	Establish Command and Control	SO or SV **
45.	Characterize and Test Systems	SO or SV **
46.	Achieve Nominal Orbit and Configuration	SO or SV **
47.	Establish Operational Database and Documentation	SO or SV **
48.	Authorization to Link Operational Constellation	SO or SV **
49.	Operational Trial Period	SO or SV **
50.	Anomaly Detection and Resolution	SV
51.	Operational Utility Evaluation(s)	SO or SV **
52.	SCA Transfer to Operations	SV
53.	Operational Acceptance	SO
54.	Post-Flight Review (PFR)	SV

Notes:

1. SVCC denotes the GPSW, ISSW, DMSG, MCSW, SYSW or SDTW Commander.
2. Only AF organizations are listed in this table for nominal SMC missions; there are cases where non-SMC mission partners assume responsibilities.
3. Task 41, DA Transfer to EOT/Operations SCA depends on mission.
4. \*Task 28, MDR(s)/ICE(s) tasks are listed with “or” responsibilities to indicate multiple rehearsal events are conducted by multiple organizations.
5. \*\*DA and Responsibilities for Task 29 (ORRs) and Tasks 43-49 and 51 for early on-orbit test/operations are mission dependent.
6. Task 27, Exception is SDTW small launch vehicle missions.

### 12.3 Entrance Criteria

- Completion of pre-review milestone activities as shown in Table 1.
- Assessment of the space flight worthiness per criteria set forth in Reference 1 and contractually cited documents (e.g., SMCI 63-1202, Space Flight Worthiness and its accompanying Guidelines). High-level FRR criteria include:
  1. Safety, including the details of each requirement as spelled out in SMCI 63-1202:
    - System safety engineering and management principles compliant with AFI 91-202 and DODD 5000.2R:
      - System safety programs compliant with contractually specified requirements (e.g., MIL-STD 882)
      - Risk acceptance authority defined and documented by program safety offices at appropriate levels during the system life-cycle.
      - Hazards identification performed using a systematic process which includes a detailed analysis of system hardware and software, the system environment, and intended use or application
    - Program is compliant with Range Safety requirements (e.g., EWR 127-1 or AFSPC Manual 91-710).
      - Compliance with general design safety requirements and policy verified
      - Compliance with ground operations safety requirements verified

2. Mission certification (the final certification for all mission-critical elements, including the launch vehicle and spacecraft, ensuring that the integrated system has been properly tested and processed so that the entire system will perform its required functions and is ready for launch), including:
  - The system has been successfully integrated with other major components and performance is verified acceptable
  - Overall systems integration has been completed and verified
  - Integrated system checkout has been performed and verified against systems-level specification
  - System verification processes and tests are complete
  - Contractor launch processing and launch processes have been proven, effective, applied, and verified
3. Resolution of known discrepancies, including those open from previous review(s)

**12.4 Exit Criteria**

- Completion of launch site readiness review, Aerospace President’s review, operational readiness review, flight readiness review, and launch readiness review

**12.5 Work Products**

- Space flight worthiness (SFW) report
- Launch authority certification of space flight worthiness of the integrated system (SMC Commander is responsible for certifying USAF space missions; for USAF-managed spacecraft and launch vehicles in support of non-USAF missions, the SMC Commander will be responsible for approving the USAF single manager’s certification)
- The Aerospace Corporation’s launch verification letter
- Material inspection and receiving report (Form DD-250)

Within the PER phase, the following work products are defined and stasured as follows in Table 11:

Table 11. Work Product Matrix Detail #10

<b>Critical Gated Events Work Products</b>		<b>10</b>
		<b>Flight Readiness Review (FRR)</b>
<b>MISSION ASSURANCE</b>		
1	Mission Assurance Plan	<b>F</b>
2	Risk Management Plan (RMP)	<b>F</b>
3	Program Management Plan (PMP)	<b>F</b>
<b>REQUIREMENTS, ANALYSIS &amp; VALIDATION</b>		
1	Concept of Operations (CONOPS) Plan	<b>F</b>
2	System Architecture (Block Diagrams & Functional Flow Diagrams)	<b>F</b>
3	A-Specification for System Functional Baseline	<b>F</b>
4	B-Specifications for Development	<b>F</b>

<b>Critical Gated Events Work Products</b>		<b>10</b>
		<b>Flight Readiness Review (FRR)</b>
5	C-Specifications for Configured Items (Units/Components/Processes)	F
6	Verification Cross-Reference Matrix (VCRM)	F
7	Technical Performance Measure (TPM) Plan	F
8	Interface Control Documents (Intra-ICDs) [Units/Subsystems/GSE]	F
9	Spacecraft to Payload ICD (Internal)	F
10	Spacecraft to Launch Vehicle ICD (External)	F
11	Spacecraft to Ground Station ICD (External)	F
12	Systems Engineering Management Plan (SEMP)	F
13	Requirements Verification Plan (RVP) [V&V Plan, VCRM]	F
14	Interface Verification Plan (IVP)	F
15	Analysis & Simulation Plan (ASP)	F
16	Algorithm Development Plan (ADP)	F
17	Error Budgets & Allocation Analysis	F
18	Post Delivery Support Plan (PDSP)	F
19	Technology Insertion Plan (TIP)	F
20	Analysis Verification Reports	F
21	Inspection Verification Reports	F
22	Demonstration Verification Reports	F
<b>RELIABILITY ENGINEERING</b>		
1	Reliability, Availability, Maintainability Plan (RAMP)	F
2	Reliability Analyses (Failure Prediction, FMEA, FMECA, SPF, etc.)	F
3	Critical Items List & Limited Life List	F
4	FRACAS/FRB Plan	F
<b>PARTS, MATERIALS &amp; PROCESSES (PMP) ENGINEERING</b>		
1	Parts, Material & Process (PMP) Plan	F
2	Approved Parts, Materials & Processes List (APMPL)	F
3	Major Subcontracts Plan (MSP or SCM Plan)	F
4	Contamination Control Plan (CCP)	F
<b>CONFIGURATION MANAGEMENT</b>		
1	Configuration Management Plan (CMP)	F
2	Data Management Plan (DMP)	F
<b>QUALITY ASSURANCE</b>		
1	Product Assurance Plan	F



<b>Critical Gated Events Work Products</b>		<b>10</b>
		<b>Flight Readiness Review (FRR)</b>
<b>SYSTEM SAFETY ASSURANCE</b>		
1	SSHP (System Safety & Hazard Plan) [includes Human Factors]	<b>F</b>
2	Environmental Effects Plan (EEP) [EMI/EMC Plan, Radiation Effects, etc.]	<b>F</b>
3	Electro Static Discharge Plan (ESDP) [includes Spacecraft Charging, Power Distribution & Grounding	<b>F</b>
<b>DESIGN ASSURANCE</b>		
1	Hardware Development Plan (HDP)	<b>F</b>
2	Detail Drawings	<b>F</b>
3	Assembly Drawings	<b>F</b>
4	Installation Drawings/Procedures	<b>F</b>
5	Schematics/Wiring Diagrams	<b>F</b>
6	Worst-Case Design Analyses	<b>F</b>
7	Structural, Thermal, Optical, Performance (STOP) Analyses	<b>F</b>
8	Packaging, Handling, Storage & Transportation (PHST) Plan	<b>F</b>
<b>SOFTWARE ASSURANCE</b>		
1	Software Development Plan (SDP)	<b>F</b>
2	Software Requirements Specification	<b>F</b>
3	Software Manuals	<b>F</b>
<b>MANUFACTURING ASSURANCE</b>		
1	Manufacturing Operating Plan (MOP)	<b>F</b>
2	Producibility Plan	<b>F</b>
3	Production Plan & Master Production Schedule (Capacity & Throughput Analysis)	<b>F</b>
4	Build History Planning/Work Orders	<b>F</b>
5	Kitting & Parts Status Plan	<b>F</b>
6	Facilities/Space Plan (FSP)	<b>F</b>
7	Manufacturing Facility Certification	<b>F</b>
8	Skills Training & Certification Matrix	<b>F</b>
9	GSE/STE/Tooling Certified/Calibrated/Proof-Loaded/PM Matrix	<b>F</b>
<b>INTEGRATION, TEST &amp; EVALUATION</b>		
1	Test Requirements Specification (TRS)	<b>F</b>
2	Environmental Test Requirements Specification (ETRS)	<b>F</b>
3	GSE/STE ICD (Mech/Elect/Optical/Thermal)	<b>F</b>

Critical Gated Events Work Products		10
		Flight Readiness Review (FRR)
4	Embedded Test (BIT)/Integrated Diagnostics/ DFT Requirements	F
5	GSE/STE Analysis, FMEA	F
6	GSE/STE Metrology Plan	F
7	Test & Evaluation Master Plan (TEMP) [includes Design-for-Test; BIT Testing]	F
8	Top-Level Test Configuration Drawing	F
9	Thermal Vacuum Test Plan	F
10	EMI/EMC Test Plan	F
11	Vibration, Shock & Acoustics Test Plan	F
12	Mass Properties Test Plan	F
13	Test Scripts/Recipes	F
14	Test Procedures – Electrical (Functional)	F
15	Test Procedures – RF	F
16	Test Procedures – Optical	F
17	Test Procedures – Thermal Vacuum	F
18	Test Procedures – Thermal Balance	F
19	Test Procedures – Vibration/Shock	F
20	Test Procedures – Acoustic	F
21	Test Procedures – Mass Properties	F
22	Test Lab Certification	F
23	Test Verification Reports	F
24	User Guides/Test Manuals	F
<b>OPERATIONAL READINESS ASSURANCE</b>		
1	Pre-Launch DD-250	F
2	Flight Worthiness Certification by Launch Authority	F
3	Aerospace Launch Verification Letter	F
4	Early On-Orbit Testing (EOT) Report	
5	SCA Change Notice	

**C = Created:** The initial generation or first draft of a work product being developed that is under author control and has not been reviewed.

**U = Updated:** A work product that contains new information, remains under author or IPT control, and has completed an informal review process by peers.

**B = Baselined:** A prepared or concluded work product that has been iterated, has IPT or program management acceptance, is ready for a formal gated event review, and may not be changed without formal CM revision control.

**R = Revised:** A reevaluated work product that has been significantly modified, remains under CM control, and will require approval authority for changes to the technical baseline.

**F = Finalized:** Brings a work product to its final state where it has been reviewed and/or signed off by the approval authority and is available for use.

## **12.6 References**

1. SMC Satellite Consent-to-Ship to On-Orbit CONOPS, Version 1.8, 24 October 2007
2. AIAA/NRO Space Launch Integration Recommended Practices
3. SMCI 63-1202, Space Flight Worthiness
4. EWR 127-1 Eastern and Western Range Safety Requirements
5. AFSPC Manual 91-710 Range Safety User Requirements

## 13. Gate 11: Initial Checkout Review (ICR)

### 13.1 Introduction

The ICR is carried out after the satellite completes its preliminary early orbit test to accomplish the following:

- Establish command and control
- Characterize and test systems
- Achieve nominal orbit and configuration
- Establish operational database and documentation
- Perform authorization to link operational constellation
- Perform operational Trial
- Perform anomaly detection and resolution
- Perform operational utility evaluation(s)

These activities are largely accomplished within a few weeks after launch (depending on orbit transfer schedule), during which the Satellite Control Authority (SCA) resides in early on-orbit test (EOT)/operations. Additional administrative information regarding on-orbit testing can be found in, for example, Air Force Space Command Instruction 10-1204, Satellite Operations.

### 13.2 Purpose

In the technologist's vernacular, the early activities include orbit raising and station insertion; deployment of antenna solar arrays and other appendages; Sun and Earth acquisition, and body rate capture; thermal control; communication linkage to the ground station; housekeeping schedule development (daily momentum wheel desaturation, station keeping, etc.); attitude sensor alignment and gain determination; bake-out; payload activation and initial calibration; thruster calibration, end-to-end operational testing, and preliminary demonstration of operational readiness, etc. as described in Chapter 29 of the *Space Vehicle Test and Evaluation Handbook* [Reference 2]. These activities verify that the satellite operates as designed, the ground systems are ready to support operations, and the mission data can be distributed to the users. After the completion of these initial operations, thorough payload test and calibration begin, followed by normal operation.

### 13.3 Entrance Criteria

1. Early orbit operations and preliminary check-out are completed.
2. Flight performances meet mission requirements.
3. Ground segment meets ICD requirements.
4. Ground operation performs efficiently and effectively.
5. Data is successfully disseminated to users.
6. Planning for follow-on testing and operations is updated.

### 13.4 Exit Criteria

1. Satisfactory review of:
  - Space segment performance summary, including:
    - Launch vehicle and transfer vehicle performance, including deviations from ICD
    - Orbit burn, spin control during burn, and final orbit, including anomalies
    - All major post-separation activities, including anomalies
    - Guidance, navigation, and control subsystem performance

- Command and data handling subsystem performance
- Software subsystem performance
- Thermal subsystem performance
- Power subsystem performance
- Telemetry, tracking, and command subsystem performance
- On-orbit propulsion subsystem performance, including an updated fuel usage plan
- Preliminary payload performance
- Ground segment performance summary during early orbit campaign, including:
  - Satellite communication, health monitoring, control, and tasking
  - Data reduction and distribution
  - Simulator and modeling fidelity analysis
  - Factory support
  - Anomaly handling and reprogramming capability
- Updated plan for follow-on early orbit tests, calibration, and operational instructions based on flight performance
- Anomaly handling and analysis
- Lessons learned, including reach-forward for subsequent flights

### 13.5 Work Products

- Early on-orbit test report
- Satellite Control Authority (SCA) Change Notice (SCA transfers from the Wing to Operations, if applicable)

Within the PER phase, the following work products are defined and stated as follows in Table 12:

Table 12. Work Product Matrix Detail #11

<b>Critical Gated Events Work Products</b>		<b>11</b>
		<b>Flight Readiness Review (FRR)</b>
<b>MISSION ASSURANCE</b>		
1	Mission Assurance Plan	<b>F</b>
2	Risk Management Plan (RMP)	<b>F</b>
3	Program Management Plan (PMP)	<b>F</b>
<b>REQUIREMENTS, ANALYSIS &amp; VALIDATION</b>		
1	Concept of Operations (CONOPS) Plan	<b>F</b>
2	System Architecture (Block Diagrams & Functional Flow Diagrams)	<b>F</b>
3	A-Specification for System Functional Baseline	<b>F</b>
4	B-Specifications for Development	<b>F</b>
5	C-Specifications for Configured Items (Units/Components/Processes)	<b>F</b>
6	Verification Cross-Reference Matrix (VCRM)	<b>F</b>
7	Technical Performance Measure (TPM) Plan	<b>F</b>
8	Interface Control Documents (Intra-ICDs) [Units/Subsystems/GSE]	<b>F</b>

<b>Critical Gated Events Work Products</b>		11
		<b>Flight Readiness Review (FRR)</b>
9	Spacecraft to Payload ICD (Internal)	F
10	Spacecraft to Launch Vehicle ICD (External)	F
11	Spacecraft to Ground Station ICD (External)	F
12	Systems Engineering Management Plan (SEMP)	F
13	Requirements Verification Plan (RVP) [V&V Plan, VCRM]	F
14	Interface Verification Plan (IVP)	F
15	Analysis & Simulation Plan (ASP)	F
16	Algorithm Development Plan (ADP)	F
17	Error Budgets & Allocation Analysis	F
18	Post Delivery Support Plan (PDSP)	F
19	Technology Insertion Plan (TIP)	F
20	Analysis Verification Reports	F
21	Inspection Verification Reports	F
22	Demonstration Verification Reports	F
<b>RELIABILITY ENGINEERING</b>		
1	Reliability, Availability, Maintainability Plan (RAMP)	F
2	Reliability Analyses (Failure Prediction, FMEA, FMECA, SPF, etc.)	F
3	Critical Items List & Limited Life List	F
4	FRACAS/FRB Plan	F
<b>PARTS, MATERIALS &amp; PROCESSES (PMP) ENGINEERING</b>		
1	Parts, Material & Process (PMP) Plan	F
2	Approved Parts, Materials & Processes List (APMPL)	F
3	Major Subcontracts Plan (MSP or SCM Plan)	F
4	Contamination Control Plan (CCP)	F
<b>CONFIGURATION MANAGEMENT</b>		
1	Configuration Management Plan (CMP)	F
2	Data Management Plan (DMP)	F
<b>QUALITY ASSURANCE</b>		
1	Product Assurance Plan	F
<b>SYSTEM SAFETY ASSURANCE</b>		
1	SSHP (System Safety & Hazard Plan) [includes Human Factors]	F
2	Environmental Effects Plan (EEP) [EMI/EMC Plan, Radiation Effects, etc.]	F
3	Electro Static Discharge Plan (ESDP) [includes Spacecraft Charging, Power Distribution & Grounding]	F

<b>Critical Gated Events Work Products</b>		11
		<b>Flight Readiness Review (FRR)</b>
<b>DESIGN ASSURANCE</b>		
1	Hardware Development Plan (HDP)	F
2	Detail Drawings	F
3	Assembly Drawings	F
4	Installation Drawings/Procedures	F
5	Schematics/Wiring Diagrams	F
6	Worst-Case Design Analyses	F
7	Structural, Thermal, Optical, Performance (STOP) Analyses	F
8	Packaging, Handling, Storage & Transportation (PHST) Plan	F
<b>SOFTWARE ASSURANCE</b>		
1	Software Development Plan (SDP)	F
2	Software Requirements Specification	F
3	Software Manuals	F
<b>MANUFACTURING ASSURANCE</b>		
1	Manufacturing Operating Plan (MOP)	F
2	Producibility Plan	F
3	Production Plan & Master Production Schedule (Capacity & Throughput Analysis)	F
4	Build History Planning/Work Orders	F
5	Kitting & Parts Status Plan	F
6	Facilities/Space Plan (FSP)	F
7	Manufacturing Facility Certification	F
8	Skills Training & Certification Matrix	F
9	GSE/STE/Tooling Certified/Calibrated/Proof-Loaded/PM Matrix	F
<b>INTEGRATION, TEST &amp; EVALUATION</b>		
1	Test Requirements Specification (TRS)	F
2	Environmental Test Requirements Specification (ETRS)	F
3	GSE/STE ICD (Mech/Elect/Optical/Thermal)	F
4	Embedded Test (BIT)/Integrated Diagnostics/ DFT Requirements	F
5	GSE/STE Analysis, FMEA	F
6	GSE/STE Metrology Plan	F
7	Test & Evaluation Master Plan (TEMP) [includes Design-for-Test; BIT Testing]	F
8	Top-Level Test Configuration Drawing	F
9	Thermal Vacuum Test Plan	F

Critical Gated Events Work Products		11
		Flight Readiness Review (FRR)
10	EMI/EMC Test Plan	F
11	Vibration, Shock & Acoustics Test Plan	F
12	Mass Properties Test Plan	F
13	Test Scripts/Recipes	F
14	Test Procedures – Electrical (Functional)	F
15	Test Procedures – RF	F
16	Test Procedures – Optical	F
17	Test Procedures – Thermal Vacuum	F
18	Test Procedures – Thermal Balance	F
19	Test Procedures – Vibration/Shock	F
20	Test Procedures – Acoustic	F
21	Test Procedures – Mass Properties	F
22	Test Lab Certification	F
23	Test Verification Reports	F
24	User Guides/Test Manuals	F
<b>OPERATIONAL READINESS ASSURANCE</b>		
1	Pre-Launch DD-250	F
2	Flight Worthiness Certification by Launch Authority	F
3	Aerospace Launch Verification Letter	F
4	Early On-Orbit Testing (EOT) Report	F
5	SCA Change Notice	F

**C = Created:** The initial generation or first draft of a work product being developed that is under author control and has not been reviewed.

**U = Updated:** A work product that contains new information, remains under author or IPT control, and has completed an informal review process by peers.

**B = Baselined:** A prepared or concluded work product that has been iterated, has IPT or program management acceptance, is ready for a formal gated event review, and may not be changed without formal CM revision control.

**R = Revised:** A reevaluated work product that has been significantly modified, remains under CM control, and will require approval authority for changes to the technical baseline.

**F = Finalized:** Brings a work product to its final state where it has been reviewed and/or signed off by the approval authority and is available for use.

## 13.6 References

1. Air Force Space Command Instruction 10-1204, Satellite Operations, 1 June 2006
2. Aerospace TOR-2006(8546)-4591, *Space Vehicle Test and Evaluation Handbook*, 6 November 2006, Chapter 29



## 14. Work Product Matrix

<b>Maturity Terminology</b>	<p><b>C = Created:</b> The initial generation or first draft of a Work Product being developed that is under author control and has not been reviewed.</p> <p><b>U = Updated:</b> A Work Product that contains new information, remains under author or IPT control, and has completed an informal review process by peers.</p> <p><b>B = Baseline:</b> A prepared or concluded Work Product that has been iterated, has IPT or Program Management acceptance, is ready for a formal Gated Event review, and may not be changed without formal CM revision control.</p> <p><b>R = Revised:</b> A reevaluated work product that has been significantly modified, remains under CM control, and will require approval authority for changes to the technical baseline.</p> <p><b>F = Finalized:</b> Brings a Work Product to its final state where it has been reviewed and/or signed off by the approval authority and is available to be used.</p>
-----------------------------	--

<b>Critical Gated Events Work Products</b>		A	B	1	2	3	4	5	6	7	8	9	10	11
		RFP Release	Source Selection	Requirements Review (RR)	Preliminary Design Review (PDR)	Critical Design Review (CDR)	Build Readiness Review (BRR)	Test Evaluation Campaign Review (TECR)	Baseline Integrated Systems Test (BIST)	Pre Environmental Review (PER)	Pre Ship Review (PSR)	Mission Readiness Review (MRR)	Flight Readiness Review (FRR)	Initial Checkout Review (CHR)
<b>MISSION ASSURANCE</b>														
1	<p><b>Mission Assurance Plan</b></p> <ul style="list-style-type: none"> <li>• The Mission Assurance Plan (MAP) represents a complete set of activities that could be performed by the contractor / subcontractors / program, during the entire life cycle of the system(s) to ensure mission success. Mission success means the system(s) will meet specified performance and functional requirements, but also user and operator expectations in terms of end-to-end operational effectiveness, operability, suitability, supportability, and safety.</li> <li>• The MAP should be consistent with the program's Integrated Master Plan (IMP), Systems Engineering Management Plan (SEMP), and the Program Management Plan (PMP). Each contractor / subcontractors / program would tailor the activities necessary to ensure mission success for each gate described in the MAP to address the requirements, risks, and constraints of the program.</li> <li>• MA can be viewed as a set of programmatic and engineering processes organized together toward the goal of mission success as a set of core processes – listed in the categories of this matrix: Mission Assurance; Requirements, Analysis &amp; Validation; Reliability Engineering; Parts, Materials, and Processes Management; Configuration Management; Quality Assurance; System Safety Assurance; Design Assurance; Manufacturing Assurance; Software Assurance; Integration, Test, &amp; Evaluation; and Operational Readiness Assurance.</li> <li>• Mission Assurance involves a focus upon the quality of the contractual requirements, design, suppliers, manufacturing, qualification, testing, and delivery of the product.</li> </ul>			C, U, B	R	F	F	F	F	F	F	F	F	F

**Maturity Terminology**

**C = Created:** The initial generation or first draft of a Work Product being developed that is under author control and has not been reviewed.  
**U = Updated:** A Work Product that contains new information, remains under author or IPT control, and has completed an informal review process by peers.  
**B = Baselined:** A prepared or concluded Work Product that has been iterated, has IPT or Program Management acceptance, is ready for a formal Gated Event review, and may not be changed without formal CM revision control.  
**R = Revised:** A reevaluated work product that has been significantly modified, remains under CM control, and will require approval authority for changes to the technical baseline.  
**F = Finalized:** Brings a Work Product to its final state where it has been reviewed and/or signed off by the approval authority and is available to be used.

Critical Gated Events Work Products		A	B	1	2	3	4	5	6	7	8	9	10	11
		RFP Release	Source Selection	Requirements Review (RR)	Preliminary Design Review (PDR)	Critical Design Review (CDR)	Build Readiness Review (BRR)	Test Evaluation Campaign Review (TECR)	Baseline Integrated Systems Test (BIST)	Pre Environmental Review (PER)	Pre Ship Review (PSR)	Mission Readiness Review (MRR)	Flight Readiness Review (FRR)	Initial Checkout Review (CHR)
	<ul style="list-style-type: none"> <li>It provides for the methods used to measure, verify, and validate mission success through the collection of metrics, risk assessment, technical evaluations, independent assessments, reviews, and conduct of test.</li> </ul>													
2	<p><b>Risk Management Plan (RMP)</b></p> <ul style="list-style-type: none"> <li>The Risk Management Plan (RMP) describes the activities for the assessment and handling of conditions and events that pose a threat to the successful execution of a mission. Provides assurance that program &amp; system risks have been thoroughly analyzed, their impacts identified and allocated to lower-tier subsystems, components, interfaces – mitigation plans developed, executed, risks effectively controlled.</li> <li>RMP utilizes a 5-step process: 1) Planning, 2) Identification, 3) Analysis, 4) Handling, and 5) Monitoring.</li> <li>Identifies top-level system-concept technological and acquisition risks. Also, identifies the corresponding system-concept risk mitigation strategies.</li> <li>Assesses &amp; verifies subcontractor risk handling plans also.</li> <li>Used to support PM function and is concerned with events that may have adverse effect on program execution from a cost, performance, or schedule basis.</li> </ul>			C, U, B	R	R	R	R	F	F	F	F	F	F
3	<p><b>Program Management Plan (PMP)</b></p> <ul style="list-style-type: none"> <li>The Program Management Plan (PMP) identifies, tracks, and manages how the program IMP elements – such as events, accomplishments, and criteria are linked.</li> <li>Describes how all Program plans are used and maintained.</li> </ul>			C, U, B	R	R	R	R	R	F	F	F	F	F

**Maturity Terminology**

**C = Created:** The initial generation or first draft of a Work Product being developed that is under author control and has not been reviewed.

**U = Updated:** A Work Product that contains new information, remains under author or IPT control, and has completed an informal review process by peers.

**B = Baselined:** A prepared or concluded Work Product that has been iterated, has IPT or Program Management acceptance, is ready for a formal Gated Event review, and may not be changed without formal CM revision control.

**R = Revised:** A reevaluated work product that has been significantly modified, remains under CM control, and will require approval authority for changes to the technical baseline.

**F = Finalized:** Brings a Work Product to its final state where it has been reviewed and/or signed off by the approval authority and is available to be used.

Critical Gated Events Work Products		A	B	1	2	3	4	5	6	7	8	9	10	11
		RFP Release	Source Selection	Requirements Review (RR)	Preliminary Design Review (PDR)	Critical Design Review (CDR)	Build Readiness Review (BRR)	Test Evaluation Campaign Review (TECR)	Baseline Integrated Systems Test (BIST)	Pre Environmental Review (PER)	Pre Ship Review (PSR)	Mission Readiness Review (MRR)	Flight Readiness Review (FRR)	Initial Checkout Review (CHR)
	<ul style="list-style-type: none"> <li>Describes in detail: Program Overview; Relationship to Company business objectives/5-Yr plan; Legal &amp; Contracts Review; RFP vs Contract deltas; Program Vision &amp; Strategy; Program Kick-off &amp; Execution; Program/IPT/Functional organizations; Contract Baseline/CLIN Summary/CDRL-delivery; SOW &amp; deliverables; IMS Development; Product &amp; Work Breakdown Structures; EVMS; Baseline Budget Management; Program Metrics; Property &amp; Capital Asset Management; People Resources (Personnel/Staffing/Training); Program Knowledge Transfer &amp; Lessons Learned; Technical/Independent/Gate Assessment Planning; Customer Communications Plan; Key Technology Assessment; Subcontract Management; Program Risk Summary; Technical Plan Summary (Key Product Parameters/Technical Performance Measures); Mission Assurance drivers.</li> </ul>													
<b>REQUIREMENTS, ANALYSIS &amp; VALIDATION</b>														
1	<p><b>CONOPS (Concept of Operations) Plan</b></p> <ul style="list-style-type: none"> <li>The CONOPS Plan describes the General Theory of Operation for the system designed and includes the Concept definition, System requirements, trade studies, and final system concept – which the Government approves at the close of the RR phase. The plan describes the user's operational needs as they relate to the Ground, SV, LV technical specifications and capabilities.</li> <li>Includes: Fault Management, Health and Status Reporting, Anomaly Resolution, On-Orbit SW Modifications, Subsystem activation, Calibrations &amp; Maintenance, Redundancy management, Simultaneous Operations, On-board &amp; Command Processing, Operational Modes, SV Subsystem interfaces, etc.</li> </ul>			C, U, B	R	F	F	F	F	F	F	F	F	F

<b>Maturity Terminology</b>	<b>C = Created:</b> The initial generation or first draft of a Work Product being developed that is under author control and has not been reviewed.
	<b>U = Updated:</b> A Work Product that contains new information, remains under author or IPT control, and has completed an informal review process by peers.
	<b>B = Baseline:</b> A prepared or concluded Work Product that has been iterated, has IPT or Program Management acceptance, is ready for a formal Gated Event review, and may not be changed without formal CM revision control.
	<b>R = Revised:</b> A reevaluated work product that has been significantly modified, remains under CM control, and will require approval authority for changes to the technical baseline.
	<b>F = Finalized:</b> Brings a Work Product to its final state where it has been reviewed and/or signed off by the approval authority and is available to be used.

<b>Critical Gated Events Work Products</b>		<b>A</b>	<b>B</b>	<b>1</b>	<b>2</b>	<b>3</b>	<b>4</b>	<b>5</b>	<b>6</b>	<b>7</b>	<b>8</b>	<b>9</b>	<b>10</b>	<b>11</b>
		<b>RFP Release</b>	<b>Source Selection</b>	<b>Requirements Review (RR)</b>	<b>Preliminary Design Review (PDR)</b>	<b>Critical Design Review (CDR)</b>	<b>Build Readiness Review (BRR)</b>	<b>Test Evaluation Campaign Review (TECR)</b>	<b>Baseline Integrated Systems Test (BIST)</b>	<b>Pre Environmental Review (PER)</b>	<b>Pre Ship Review (PSR)</b>	<b>Mission Readiness Review (MRR)</b>	<b>Flight Readiness Review (FRR)</b>	<b>Initial Checkout Review (CHR)</b>
	<ul style="list-style-type: none"> <li>The CONOPS Plan is typically a CDRL-item that will describe the system architecture and operational modes, in order to provide traceability between design specifications, verification requirements, and operating procedures.</li> <li>Besides describing the basic needs, intended use, and required support for the new System - it describes the general operating characteristics of the entire space system including: basic functions, interoperability requirements, dependencies, and desired interfaces envisioned in the new/upgraded Space System.</li> <li>Contents include: Mission Description, Background/Objectives/Scope, Description of system, Modes of Operation, Users/Stakeholders, Support environment, Operational scenarios, Fault management, Future architecture.</li> </ul>													
2	<p><b>System Architecture (Block Diagrams &amp; Functional Flow Diagrams)</b></p> <ul style="list-style-type: none"> <li>The hierarchical arrangement of product and process solutions, their functional performance requirements, their internal &amp; external functional and physical interfaces and requirements, and the physical constraints that form the basis of design requirements.</li> <li>The physical architecture provides the basis for system/control item baselines as a function of the acquisition phase.</li> <li>The basis for assembling function performance requirements and criteria into an integrated set of design requirements for the system.</li> <li>A systematic process that translates system requirements through mission analysis, functional architecture definition, physical architecture definition, and requirements definition to enable system development.</li> </ul>			<b>C, U, B</b>	<b>R</b>	<b>F</b>	<b>F</b>	<b>F</b>	<b>F</b>	<b>F</b>	<b>F</b>	<b>F</b>	<b>F</b>	<b>F</b>

**Maturity Terminology**

**C = Created:** The initial generation or first draft of a Work Product being developed that is under author control and has not been reviewed.  
**U = Updated:** A Work Product that contains new information, remains under author or IPT control, and has completed an informal review process by peers.  
**B = Baselined:** A prepared or concluded Work Product that has been iterated, has IPT or Program Management acceptance, is ready for a formal Gated Event review, and may not be changed without formal CM revision control.  
**R = Revised:** A reevaluated work product that has been significantly modified, remains under CM control, and will require approval authority for changes to the technical baseline.  
**F = Finalized:** Brings a Work Product to its final state where it has been reviewed and/or signed off by the approval authority and is available to be used.

Critical Gated Events Work Products		A	B	1	2	3	4	5	6	7	8	9	10	11
		RFP Release	Source Selection	Requirements Review (RR)	Preliminary Design Review (PDR)	Critical Design Review (CDR)	Build Readiness Review (BRR)	Test Evaluation Campaign Review (TECR)	Baseline Integrated Systems Test (BIST)	Pre Environmental Review (PER)	Pre Ship Review (PSR)	Mission Readiness Review (MRR)	Flight Readiness Review (FRR)	Initial Checkout Review (CHR)
	<ul style="list-style-type: none"> <li>Block diagrams provide a static view of all essential system elements of the system. Functional Flow Diagrams provide a dynamic view of the system - power, communications, C&amp;C flows for the system.</li> </ul>													
3	<p>A-Specification for System Functional Baseline</p> <ul style="list-style-type: none"> <li>The A-Spec is the MIL-STD 490A designation for the System Specification.</li> <li>It defines the functional baseline in terms of quantitative technical performance parameters.</li> </ul>			C, U, B	R	F	F	F	F	F	F	F	F	F
4	<p>B-Specifications for Development</p> <ul style="list-style-type: none"> <li>The B-Specification represents the Development Specifications (multiple ones).</li> <li>B-Specification &gt; Subsystem &gt; subsystem block diagram &amp; SW interface.</li> <li>It defines the specified performance through system analysis &amp; trade-offs from the A-Spec.</li> <li>B1 Spec is the Prime Item Development specification.</li> <li>B2 Spec is the Critical Item Development specification.</li> <li>B3 Spec is the Non-Complex Item Development specification.</li> <li>B4 Spec is the Facility Development specification.</li> <li>B5 Spec is the Software Requirements specification.</li> </ul>			C, U	B	R	F	F	F	F	F	F	F	F
5	<p>C-Specifications for Configured Item's (Units/Components/Processes)</p> <ul style="list-style-type: none"> <li>The C-Spec represents the Unit or Configured Item (CI) specifications (multiple ones).</li> <li>It defines the as-built performance requirements of the lower-level CI - the performance which has been determined and verified through the product lifecycle, including successful FCA/PCA reviews.</li> </ul>				C, U	B	R	F	F	F	F	F	F	F

**Maturity Terminology**

**C = Created:** The initial generation or first draft of a Work Product being developed that is under author control and has not been reviewed.  
**U = Updated:** A Work Product that contains new information, remains under author or IPT control, and has completed an informal review process by peers.  
**B = Baseline:** A prepared or concluded Work Product that has been iterated, has IPT or Program Management acceptance, is ready for a formal Gated Event review, and may not be changed without formal CM revision control.  
**R = Revised:** A reevaluated work product that has been significantly modified, remains under CM control, and will require approval authority for changes to the technical baseline.  
**F = Finalized:** Brings a Work Product to its final state where it has been reviewed and/or signed off by the approval authority and is available to be used.

Critical Gated Events Work Products		A	B	1	2	3	4	5	6	7	8	9	10	11
		RFP Release	Source Selection	Requirements Review (RR)	Preliminary Design Review (PDR)	Critical Design Review (CDR)	Build Readiness Review (BRR)	Test Evaluation Campaign Review (TECR)	Baseline Integrated Systems Test (BIST)	Pre Environmental Review (PER)	Pre Ship Review (PSR)	Mission Readiness Review (MRR)	Flight Readiness Review (FRR)	Initial Checkout Review (CHR)
	<ul style="list-style-type: none"> <li>C1A Spec is the Prime Item Product Function specification.</li> <li>C1B Spec is the Prime Item Product Fabrication specification.</li> <li>C2A Spec is the Critical Item Product Function specification.</li> <li>C2B Spec is the Critical Item Product Fabrication specification.</li> <li>C3 Spec is the Non-Complex Item Product Fabrication specification.</li> <li>C4 Spec is the Inventory Item specification.</li> <li>C5 Spec is the SW Product specification.</li> </ul>													
6	<p>Verification Correlation Requirements Matrix (VCRM)</p> <ul style="list-style-type: none"> <li>A matrix used to cross-reference requirements to the test methods and test definitions used to verify the requirements. VCRM's usually appear in the Qualification Requirements section of a requirements spec, as well as in the related system/subsystem/product test plan.</li> <li>The matrix that is developed to reference the verification methodology (Test/Inspection /Demonstration/Analysis/Simulation) used to verify the requirements.</li> </ul>			C, U, B	R	F	F	F	F	F	F	F	F	F
7	<p>TPM (Technical Performance Measures) Plan</p> <ul style="list-style-type: none"> <li>The continuing verification of the degree of anticipated and actual achievement of technical parameters.</li> <li>TPM's are used to identify and flag the importance of a design deficiency that might jeopardize meeting a system level requirement that has been determined to be critical.</li> <li>Measured values that fall outside an established tolerance band require proper corrective actions to be taken by Program Management.</li> <li>Relevant terms and relationships include 1) Achievement to Date; 2) Current Estimates; 3) Technical Milestones; 4) Planned Value &amp; Planned Value Profile; and 5) Threshold or Tolerance Band.</li> </ul>			C, U, B	R	F	F	F	F	F	F	F	F	F

**Maturity Terminology**

**C = Created:** The initial generation or first draft of a Work Product being developed that is under author control and has not been reviewed.  
**U = Updated:** A Work Product that contains new information, remains under author or IPT control, and has completed an informal review process by peers.  
**B = Baseline:** A prepared or concluded Work Product that has been iterated, has IPT or Program Management acceptance, is ready for a formal Gated Event review, and may not be changed without formal CM revision control.  
**R = Revised:** A reevaluated work product that has been significantly modified, remains under CM control, and will require approval authority for changes to the technical baseline.  
**F = Finalized:** Brings a Work Product to its final state where it has been reviewed and/or signed off by the approval authority and is available to be used.

Critical Gated Events Work Products		A	B	1	2	3	4	5	6	7	8	9	10	11
		RFP Release	Source Selection	Requirements Review (RR)	Preliminary Design Review (PDR)	Critical Design Review (CDR)	Build Readiness Review (BRR)	Test Evaluation Campaign Review (TECR)	Baseline Integrated Systems Test (BIST)	Pre Environmental Review (PER)	Pre Ship Review (PSR)	Mission Readiness Review (MRR)	Flight Readiness Review (FRR)	Initial Checkout Review (CHR)
	<ul style="list-style-type: none"> <li>A selected subset of the system's technical metrics tracked in a TPM. Critical technical parameters are identified from risk analyses and contract specification and are designated by program management, including: 1) Specification requirements; 2) Metrics associated with technical objectives and other key decision metrics used to guide &amp; control development; 3) Design-to-Cost requirements; and 4) Parameters identified in the acquisition program baseline or user requirements documentation.</li> </ul>													
8	<p>Intra-ICDs (Interface Control Documents) [Units/Subsystems/GSE]</p> <ul style="list-style-type: none"> <li>Documents resulting from the SEMP that describe how interface requirements will be accomplished.</li> <li>The physical or functional boundary within a contractor's project, typically between assemblies and is managed by the Design Integration function.</li> <li>The Interface Requirements Specification specifies the interfaces between two or more entities (e.g., systems/segments/elements/or CI's).</li> <li>The Interface Specification is the performance specification that defines the physical, functional, and operational characteristics &amp; parameters of the interfaces between two associate contractors.</li> </ul>			C, U	B	R	R	R	F	F	F	F	F	F
9	<p>Spacecraft to Payload ICD (Internal)</p> <ul style="list-style-type: none"> <li>Establishment of ICWG (Interface Control Working Group) and sub-divided into specialized areas (e.g., EMC, Software, Test Planning, etc.)</li> <li>ICD's may be captured in interface requirements specifications, design drawings, or other co-functioning systems/components.</li> <li>Describes the "design implementation" of the requirements outlined in the specification – should not duplicate a design specification.</li> </ul>			C, U	B	R	R	R	F	F	F	F	F	F

<b>Maturity Terminology</b>	<b>C = Created:</b> The initial generation or first draft of a Work Product being developed that is under author control and has not been reviewed.
	<b>U = Updated:</b> A Work Product that contains new information, remains under author or IPT control, and has completed an informal review process by peers.
	<b>B = Baseline:</b> A prepared or concluded Work Product that has been iterated, has IPT or Program Management acceptance, is ready for a formal Gated Event review, and may not be changed without formal CM revision control.
	<b>R = Revised:</b> A reevaluated work product that has been significantly modified, remains under CM control, and will require approval authority for changes to the technical baseline.
	<b>F = Finalized:</b> Brings a Work Product to its final state where it has been reviewed and/or signed off by the approval authority and is available to be used.

<b>Critical Gated Events Work Products</b>		<b>A</b>	<b>B</b>	<b>1</b>	<b>2</b>	<b>3</b>	<b>4</b>	<b>5</b>	<b>6</b>	<b>7</b>	<b>8</b>	<b>9</b>	<b>10</b>	<b>11</b>
		RFP Release	Source Selection	Requirements Review (RR)	Preliminary Design Review (PDR)	Critical Design Review (CDR)	Build Readiness Review (BRR)	Test Evaluation Campaign Review (TECR)	Baseline Integrated Systems Test (BIST)	Pre Environmental Review (PER)	Pre Ship Review (PSR)	Mission Readiness Review (MRR)	Flight Readiness Review (FRR)	Initial Checkout Review (CHR)
	<ul style="list-style-type: none"> <li>Describes usage of industry standards/protocols, provisions for upgrading through higher performance items (with minimal impact on system), and modular design elements.</li> </ul>													
10	Spacecraft to Launch Vehicle ICD (External) <ul style="list-style-type: none"> <li>Establishment of ICWG (Interface Control Working Group)</li> <li>To Be Supplied (TBS)</li> </ul>			C, U	B	R	R	R	F	F	F	F	F	F
11	Spacecraft to Ground Station ICD (External) <ul style="list-style-type: none"> <li>Establishment of ICWG (Interface Control Working Group)</li> <li>To Be Supplied (TBS)</li> </ul>			C, U	B	R	R	R	F	F	F	F	F	F
12	Systems Engineering Management Plan (SEMP) <ul style="list-style-type: none"> <li>A comprehensive document that describes how the fully integrated engineering effort will be managed and conducted.</li> <li>Describes the overall policies and methods for System Engineering Management to be used during the life cycle of the program.</li> </ul>			C	U	B	F	F	F	F	F	F	F	F
13	Requirements Verification Plan (RVP) [V&V Plan, VCRM] <ul style="list-style-type: none"> <li>Defines the sequence by which products and components (HW &amp; SW) are combined into a functioning and unified higher-level element with all interfaces working.</li> <li>The plan which identifies the processes, tasks, and actions used for a verifying a delivered system's requirements using one of 5 methods: 1) Analysis, 2) Simulation, 3) Demonstration, 4) Inspection, and 5) Test.</li> <li>A matrix used to cross-reference requirements to the test and test definitions used to verify the requirements.</li> </ul>			C	U	B	R	R	F	F	F	F	F	F



**Maturity Terminology**

**C = Created:** The initial generation or first draft of a Work Product being developed that is under author control and has not been reviewed.  
**U = Updated:** A Work Product that contains new information, remains under author or IPT control, and has completed an informal review process by peers.  
**B = Baseline:** A prepared or concluded Work Product that has been iterated, has IPT or Program Management acceptance, is ready for a formal Gated Event review, and may not be changed without formal CM revision control.  
**R = Revised:** A reevaluated work product that has been significantly modified, remains under CM control, and will require approval authority for changes to the technical baseline.  
**F = Finalized:** Brings a Work Product to its final state where it has been reviewed and/or signed off by the approval authority and is available to be used.

Critical Gated Events Work Products		A	B	1	2	3	4	5	6	7	8	9	10	11
		RFP Release	Source Selection	Requirements Review (RR)	Preliminary Design Review (PDR)	Critical Design Review (CDR)	Build Readiness Review (BRR)	Test Evaluation Campaign Review (TECR)	Baseline Integrated Systems Test (BIST)	Pre Environmental Review (PER)	Pre Ship Review (PSR)	Mission Readiness Review (MRR)	Flight Readiness Review (FRR)	Initial Checkout Review (CHR)
	<ul style="list-style-type: none"> <li>The RVP describes verification tasks to be carried out with flight hardware at the component level, sensor level, and payload level. In addition, verification tasks utilizing the Test Bed, Software Qualification Testbed, and simulation/analysis are described.</li> </ul>													
14	<p>Interface Verification Plan (IVP)</p> <ul style="list-style-type: none"> <li>The Interface Verification Plan (IVP) presents the requirements verification methodology for (TBS).</li> <li>The plan describes the level of testing, the tasks at each level, and the accept/reject criteria for each task.</li> <li>At the Payload Software Level (PL/SW), emulators are extensively used to verify the software requirements.</li> <li>The verification plan involves Payload Commands, Payload Health &amp; Status, Processed Mission Data, Raw Mission Data, and Ground Modifiable Memory (GMM).</li> </ul>			C	U	U	B	R	F	R	F	F	F	F
15	<p>Analysis &amp; Simulation Plan (ASP)</p> <ul style="list-style-type: none"> <li>The Analysis &amp; Simulation Plan (ASP) contains flow diagram(s) for each analysis activity listed in the Requirements Verification Plan, Calibration Plan, and Interface Verification Plan. Each flow diagram identifies data inputs, analysis actions to be performed (functions), data outputs, and tools used to perform the analysis.</li> <li>Data input sources are Subsystem Testing, Engineering Model Testing, Component Level Testing, and other Analysis activities. Functions are calculations, interpolations, extrapolations, interpretations, comparisons, and simulations. Analysis tools are structural models, thermal models, flight software simulation, LOS simulation, ray tracing, and environmental simulation.</li> </ul>			C	U	B	F	F	F	F	F	F	F	F
16	<p>Algorithm Development Plan (ADP)</p>			C	U	U	B	R	F	R	F	F	F	F

**Maturity Terminology**

**C = Created:** The initial generation or first draft of a Work Product being developed that is under author control and has not been reviewed.  
**U = Updated:** A Work Product that contains new information, remains under author or IPT control, and has completed an informal review process by peers.  
**B = Baseline:** A prepared or concluded Work Product that has been iterated, has IPT or Program Management acceptance, is ready for a formal Gated Event review, and may not be changed without formal CM revision control.  
**R = Revised:** A reevaluated work product that has been significantly modified, remains under CM control, and will require approval authority for changes to the technical baseline.  
**F = Finalized:** Brings a Work Product to its final state where it has been reviewed and/or signed off by the approval authority and is available to be used.

Critical Gated Events Work Products		A	B	1	2	3	4	5	6	7	8	9	10	11
		RFP Release	Source Selection	Requirements Review (RR)	Preliminary Design Review (PDR)	Critical Design Review (CDR)	Build Readiness Review (BRR)	Test Evaluation Campaign Review (TECR)	Baseline Integrated Systems Test (BIST)	Pre Environmental Review (PER)	Pre Ship Review (PSR)	Mission Readiness Review (MRR)	Flight Readiness Review (FRR)	Initial Checkout Review (CHR)
	<ul style="list-style-type: none"> <li>The Algorithm Development Plan describes the algorithm architecture and relationship to hardware and software architectures.</li> <li>The software design has all of the algorithm functionality running in the background, which facilitates the data flow paradigm.</li> <li>Calibration / Surveillance / Background data collection commands / Processed Mission Data Messages in a data flow block diagram.</li> </ul>													
17	<b>Error Budgets &amp; Allocation Analysis</b> <ul style="list-style-type: none"> <li>This plan describes how performance budgets are allocated to key subsystems and units.</li> <li>This includes a full-up tolerance analysis showing how design, fabrication, alignment, and environmentally-induced errors link to the error-budgets so that the as-built system is likely to meet its top-level requirements.</li> <li>Margins between predictions, specifications, and growth potential should also be summarized. Estimated tolerances on parts should be feasible using current alignment methods and measurement metrology.</li> </ul>			C, U	B	R	R	R	F	F	F	F	F	F
18	<b>Post Delivery Support Plan (PDSP)</b> <ul style="list-style-type: none"> <li>This plan describes the activities post-delivery of the SV, and include launch site activities and mission control activities.</li> </ul>			C	U	U	U	B	R	F	F	F	F	F
19	<b>Technology Insertion Plan (TIP)</b> <ul style="list-style-type: none"> <li>This plan describes development of new planned technologies to address current technology with shortfalls, or for areas that will result in a substantial product improvement. In addition, new technology may be required due to parts obsolesce, or parts from a heritage design that are no longer available.</li> <li>Technology insertion is usually associated with electronics (although not universally) since it is constantly breeding new and faster processing innovations applicable to space design.</li> </ul>			C	U	U	U	B	R	F	F	F	F	F

<b>Maturity Terminology</b>	<b>C = Created:</b> The initial generation or first draft of a Work Product being developed that is under author control and has not been reviewed.
	<b>U = Updated:</b> A Work Product that contains new information, remains under author or IPT control, and has completed an informal review process by peers.
	<b>B = Baseline:</b> A prepared or concluded Work Product that has been iterated, has IPT or Program Management acceptance, is ready for a formal Gated Event review, and may not be changed without formal CM revision control.
	<b>R = Revised:</b> A reevaluated work product that has been significantly modified, remains under CM control, and will require approval authority for changes to the technical baseline.
	<b>F = Finalized:</b> Brings a Work Product to its final state where it has been reviewed and/or signed off by the approval authority and is available to be used.

Critical Gated Events Work Products		A	B	1	2	3	4	5	6	7	8	9	10	11
		RFP Release	Source Selection	Requirements Review (RR)	Preliminary Design Review (PDR)	Critical Design Review (CDR)	Build Readiness Review (BRR)	Test Evaluation Campaign Review (TECR)	Baseline Integrated Systems Test (BIST)	Pre Environmental Review (PER)	Pre Ship Review (PSR)	Mission Readiness Review (MRR)	Fight Readiness Review (FRR)	Initial Checkout Review (CHR)
	<ul style="list-style-type: none"> <li>Contained in the plan are the lead times to develop and insert the new technologies - including qualification &amp; testing to ensure that the new technology displays no unexpected behavior over its expected lifetime and environments.</li> <li>Technology insertion into a space program mandates that proper risk assessments be employed as part of the overall planning.</li> </ul>													
20	Analysis Verification Reports - To Be Supplied (TBS)						C	B	R	R	F	F	F	F
21	Inspection Verification Reports - To Be Supplied (TBS)						C	B	R	R	F	F	F	F
22	Demonstration Verification Reports - To Be Supplied (TBS)						C	B	R	R	F	F	F	F
<b>RELIABILITY ENGINEERING</b>														
1	Reliability, Availability, Maintainability Plan (RAMP)  <ul style="list-style-type: none"> <li>The overall plan that determines the steps necessary to ensure a product will reach achieve its design life and specified in a numerical mission reliability / availability / maintainability requirement.</li> <li>It includes the activities that begin at the system level and extend all the down to the individual part level, including the following: 1) Reliability Assessment; 2) Failure Modes and Effects Analysis (FMEA)/Failure Modes and Effects Criticality Analysis (FMECA); 3) Identification of Critical Life Items; 4) Design Life Verification (Limited Life Items); and 5) Worst-Case Analyses.</li> <li>The activities start with an allocation of system reliability requirements to subsystems, continues with the reliability analysis of hardware and testing data - and ends with documented closure of all failure/anomaly reports driven to root cause and with good corrective actions.</li> </ul>			C	U	B	R	R	R	R	F	F	F	F

<b>Maturity Terminology</b>	<b>C = Created:</b> The initial generation or first draft of a Work Product being developed that is under author control and has not been reviewed.
	<b>U = Updated:</b> A Work Product that contains new information, remains under author or IPT control, and has completed an informal review process by peers.
	<b>B = Baseline:</b> A prepared or concluded Work Product that has been iterated, has IPT or Program Management acceptance, is ready for a formal Gated Event review, and may not be changed without formal CM revision control.
	<b>R = Revised:</b> A reevaluated work product that has been significantly modified, remains under CM control, and will require approval authority for changes to the technical baseline.
	<b>F = Finalized:</b> Brings a Work Product to its final state where it has been reviewed and/or signed off by the approval authority and is available to be used.

<b>Critical Gated Events Work Products</b>		<b>A</b>	<b>B</b>	<b>1</b>	<b>2</b>	<b>3</b>	<b>4</b>	<b>5</b>	<b>6</b>	<b>7</b>	<b>8</b>	<b>9</b>	<b>10</b>	<b>11</b>
		<b>RFP Release</b>	<b>Source Selection</b>	<b>Requirements Review (RR)</b>	<b>Preliminary Design Review (PDR)</b>	<b>Critical Design Review (CDR)</b>	<b>Build Readiness Review (BRR)</b>	<b>Test Evaluation Campaign Review (TECR)</b>	<b>Baseline Integrated Systems Test (BIST)</b>	<b>Pre Environmental Review (PER)</b>	<b>Pre Ship Review (PSR)</b>	<b>Mission Readiness Review (MRR)</b>	<b>Flight Readiness Review (FRR)</b>	<b>Initial Checkout Review (CHR)</b>
2	<p>Reliability Analyses (Failure Prediction, FMEA, FMECA, SPF, etc.)</p> <ul style="list-style-type: none"> <li>Reliability prediction is conducted as part of an overall modeling effort to understand the failure rate of a configured item - including units, subsystems, and system. The model is created using part-specific failure rate models for every electronic (and some mechanical parts) part type by calculating the effects of various stress factors including: environment, quality levels, voltage, frequency, and temperature. Once the part stress analysis is performed this information is rolled into an larger reliability prediction model so that the overall system reliability can be numerically expressed and verified.</li> <li>Failure Modes and Effects Analyses (FMEA) and Failure Modes and Effects Criticality Analysis (FMECA) are performed to identify HW failure modes that could impact mission and ground-support equipment critical functions due to single point failures in system components or EEE parts - so that failures can be eliminated completely. In the event that a potential critical failure mode can not be eliminated, mitigation plans were developed to ensure that the effect of the failure mode is minimized. Criticality analysis is a process by which each potential failure mode is ranked according to the combined influence of severity and probability of occurrence.</li> </ul>			C	U	B	R	R	R	R	F	F	F	F
3	<p>Critical Items List &amp; Limited Life List</p> <ul style="list-style-type: none"> <li>The CIL is a listing of Single Point Failures (SPFs) resulting in a failure which is non-recoverable loss of functionality.</li> <li>The CIL encompasses moving mechanical assemblies, static optical/mechanical assemblies, a single cable that houses both Primary &amp; redundant signals, and non-redundant electronics.</li> </ul>			C	U	B	R	R	R	F	F	F	F	F

<b>Maturity Terminology</b>	<b>C = Created:</b> The initial generation or first draft of a Work Product being developed that is under author control and has not been reviewed.
	<b>U = Updated:</b> A Work Product that contains new information, remains under author or IPT control, and has completed an informal review process by peers.
	<b>B = Baselined:</b> A prepared or concluded Work Product that has been iterated, has IPT or Program Management acceptance, is ready for a formal Gated Event review, and may not be changed without formal CM revision control.
	<b>R = Revised:</b> A reevaluated work product that has been significantly modified, remains under CM control, and will require approval authority for changes to the technical baseline.
	<b>F = Finalized:</b> Brings a Work Product to its final state where it has been reviewed and/or signed off by the approval authority and is available to be used.

<b>Critical Gated Events Work Products</b>		<b>A</b>	<b>B</b>	<b>1</b>	<b>2</b>	<b>3</b>	<b>4</b>	<b>5</b>	<b>6</b>	<b>7</b>	<b>8</b>	<b>9</b>	<b>10</b>	<b>11</b>
		RFP Release	Source Selection	Requirements Review (RR)	Preliminary Design Review (PDR)	Critical Design Review (CDR)	Build Readiness Review (BRR)	Test Evaluation Campaign Review (TECR)	Baseline Integrated Systems Test (BIST)	Pre Environmental Review (PER)	Pre Ship Review (PSR)	Mission Readiness Review (MRR)	Flight Readiness Review (FRR)	Initial Checkout Review (CHR)
	<ul style="list-style-type: none"> <li>Critical Items are items that require special attention because of the complexity, application of state-of-the-art techniques, the impact of potential failure, or the anticipated reliability problems.</li> <li>An item is designated critical if it does not have sufficient history of operation or similarity, stressed in excess of derating criteria; has an environmentally exposure limitation; has a limited operating life; or requires special handling/storage/use.</li> </ul>													
4	<b>FRACAS/FRB Plan</b> <ul style="list-style-type: none"> <li>A plan which describes how test failures and anomalies are initially identified, investigated, reported, and dispositioned in a consistent and timely manner - ensuring that no overstress has occurred to the Flight Hardware.</li> </ul>					C	B	R	R	F	F	F	F	F
<b>PARTS, MATERIALS &amp; PROCESSES (PMP) ENGINEERING</b>														
1	<b>Parts, Material &amp; Process Plan (PMP)</b> <ul style="list-style-type: none"> <li>The plan that describes: 1) Definition of PMP requirements that apply to a system (found in the system spec); 2) Generation of a Program approved APMPL; 3) Appointment of a PMP Control Board; 4) Generation of a part stress derating policy; 6) Definition &amp; implementation of radiation hardness requirements; and 7) Definition of minimal qualification/OC/screening requirements for candidate parts.</li> </ul>			C, U	B	R	F	F	F	F	F	F	F	F
2	<b>Approved Parts, Materials &amp; Processes List (APMPL)</b> <ul style="list-style-type: none"> <li>A listing of all parts, materials, and processes authorized for use on a specific program based-on a detailed analytical review process that meets proper application, derating margin, BOL/EOL criteria, and other system performance criteria.</li> </ul>			C, U	B	R	R	R	F	F	F	F	F	F
3	<b>Major Subcontracts Plan (MSP or SCM Plan)</b> <ul style="list-style-type: none"> <li>Used to identify Long Lead procurements.</li> </ul>			C, U	B	R	F	F	F	F	F	F	F	F

<b>Maturity Terminology</b>	<b>C = Created:</b> The initial generation or first draft of a Work Product being developed that is under author control and has not been reviewed.
	<b>U = Updated:</b> A Work Product that contains new information, remains under author or IPT control, and has completed an informal review process by peers.
	<b>B = Baselined:</b> A prepared or concluded Work Product that has been iterated, has IPT or Program Management acceptance, is ready for a formal Gated Event review, and may not be changed without formal CM revision control.
	<b>R = Revised:</b> A reevaluated work product that has been significantly modified, remains under CM control, and will require approval authority for changes to the technical baseline.
	<b>F = Finalized:</b> Brings a Work Product to its final state where it has been reviewed and/or signed off by the approval authority and is available to be used.

<b>Critical Gated Events Work Products</b>		<b>A</b>	<b>B</b>	<b>1</b>	<b>2</b>	<b>3</b>	<b>4</b>	<b>5</b>	<b>6</b>	<b>7</b>	<b>8</b>	<b>9</b>	<b>10</b>	<b>11</b>
		RFP Release	Source Selection	Requirements Review (RR)	Preliminary Design Review (PDR)	Critical Design Review (CDR)	Build Readiness Review (BRR)	Test Evaluation Campaign Review (TECR)	Baseline Integrated Systems Test (BIST)	Pre Environmental Review (PER)	Pre Ship Review (PSR)	Mission Readiness Review (MRR)	Flight Readiness Review (FRR)	Initial Checkout Review (CHR)
	<ul style="list-style-type: none"> <li>Also, identifies obsolete parts for new builds of heritage equipment.</li> <li>Identifies a listing of potential suppliers with verified capabilities &amp; capacity to handle new procurements for make vs buy decisions.</li> </ul>													
4	<p>Contamination Control Plan (CCP)</p> <ul style="list-style-type: none"> <li>The plan describes the procedures &amp; process used to properly screen parts &amp; materials for program approval - ensuring that performance loss is not reached until EOL or end of mission. This also includes the evaluation for prohibited materials (e.g., pure tin, zinc, cadmium, etc.) of incoming metallic parts with coatings/plating's, as well as screening for silver-filled epoxies, silicone-based coatings, and overall qualified processes prior to manufacturing.</li> <li>Contamination consists of unwanted foreign matter that can degrade product quality or performance: 1) molecular films that outgas from nonmetallic materials in space, or through ambient environments during processing; and 2) dust particles generated from the manufacturing process, as well as exposure to uncontrolled environments.</li> </ul>			C	U	B	R	R	F	F	F	F	F	F
<b>CONFIGURATION MANAGEMENT</b>														
1	<p>Configuration Management Plan (CMP)</p> <ul style="list-style-type: none"> <li>The configuration management plan describes the technical and administrative processes used to document &amp; control a program's system baseline – including HW, SW, data interfaces, procedures &amp; processes.</li> <li>The CM Plan is based on the concept of configured items (CI's) where a CI may be defined as an individual item (e.g., HW component, SW module, or higher-level subsystem, etc.) and it's documented performance attributes, including managing changes to those attributes throughout the design, manufacturing, assembly, testing, verification, or operation steps.</li> </ul>			C, U	B	R	R	F	F	F	F	F	F	F

<b>Maturity Terminology</b>	<b>C = Created:</b> The initial generation or first draft of a Work Product being developed that is under author control and has not been reviewed.
	<b>U = Updated:</b> A Work Product that contains new information, remains under author or IPT control, and has completed an informal review process by peers.
	<b>B = Baseline:</b> A prepared or concluded Work Product that has been iterated, has IPT or Program Management acceptance, is ready for a formal Gated Event review, and may not be changed without formal CM revision control.
	<b>R = Revised:</b> A reevaluated work product that has been significantly modified, remains under CM control, and will require approval authority for changes to the technical baseline.
	<b>F = Finalized:</b> Brings a Work Product to its final state where it has been reviewed and/or signed off by the approval authority and is available to be used.

<b>Critical Gated Events Work Products</b>		<b>A</b>	<b>B</b>	<b>1</b>	<b>2</b>	<b>3</b>	<b>4</b>	<b>5</b>	<b>6</b>	<b>7</b>	<b>8</b>	<b>9</b>	<b>10</b>	<b>11</b>
		<b>RFP Release</b>	<b>Source Selection</b>	<b>Requirements Review (RR)</b>	<b>Preliminary Design Review (PDR)</b>	<b>Critical Design Review (CDR)</b>	<b>Build Readiness Review (BRR)</b>	<b>Test Evaluation Campaign Review (TECR)</b>	<b>Baseline Integrated Systems Test (BIST)</b>	<b>Pre Environmental Review (PER)</b>	<b>Pre Ship Review (PSR)</b>	<b>Mission Readiness Review (MRR)</b>	<b>Flight Readiness Review (FRR)</b>	<b>Initial Checkout Review (CHR)</b>
<b>2</b>	<b>Data Management Plan (DMP)</b> <ul style="list-style-type: none"> <li>The data management plan describes the process for capturing, storing, and retrieving of project data &amp; information represented by the program baseline (functional, allocated, and physical) and the entirety of its changes throughout the product lifecycle.</li> <li>Data management provides a central location where all data &amp; information is controlled and maintained for contractual purposes.</li> </ul>			<b>C, U</b>	<b>B</b>	<b>R</b>	<b>R</b>	<b>F</b>	<b>F</b>	<b>F</b>	<b>F</b>	<b>F</b>	<b>F</b>	<b>F</b>
<b>QUALITY ASSURANCE</b>														
<b>1</b>	<b>Product Assurance Plan</b> <ul style="list-style-type: none"> <li>The PA Plan defines the requirements for quality management systems and is used to demonstrate an organization's capability to provide products that meet customer and applicable regulatory requirements, as well as meet the quality requirements specific to the: Program Quality Management requirements; quality controls during the design, manufacturing, and test phases of a program; and the Quality control of purchases.</li> <li>Typically addressed in all Product Assurance Plans, which are based on ISO 9001 or AS9100B documents, the following 20 items are addressed by the Product or Quality Assurance Plan: 1) Management Responsibility; 2) Quality Systems; 3) Contract Review; 4) Design Control; 5) Document &amp; Data Control; 6) Purchasing; 7) Control of Supplied Product; 8) Project Identification; 9) Process Control; 10) Inspection &amp; Testing; 11) Control of Inspection, Measuring, and Test Equipment; 12) Inspection &amp; Test Status; 13) Control of Nonconforming Product; 14) Corrective &amp; Preventive Action; 15) Handling, Storage, Preservation, and Delivery; 16) Control of Quality Records; 17) Internal Quality Audits; 18) Training; 19) Servicing; and 20) Statistical Techniques.</li> </ul>			<b>C</b>	<b>U</b>	<b>B</b>	<b>R</b>	<b>F</b>	<b>F</b>	<b>F</b>	<b>F</b>	<b>F</b>	<b>F</b>	<b>F</b>

<b>Maturity Terminology</b>	<b>C = Created:</b> The initial generation or first draft of a Work Product being developed that is under author control and has not been reviewed.
	<b>U = Updated:</b> A Work Product that contains new information, remains under author or IPT control, and has completed an informal review process by peers.
	<b>B = Baselined:</b> A prepared or concluded Work Product that has been iterated, has IPT or Program Management acceptance, is ready for a formal Gated Event review, and may not be changed without formal CM revision control.
	<b>R = Revised:</b> A reevaluated work product that has been significantly modified, remains under CM control, and will require approval authority for changes to the technical baseline.
	<b>F = Finalized:</b> Brings a Work Product to its final state where it has been reviewed and/or signed off by the approval authority and is available to be used.

<b>Critical Gated Events Work Products</b>		<b>A</b>	<b>B</b>	<b>1</b>	<b>2</b>	<b>3</b>	<b>4</b>	<b>5</b>	<b>6</b>	<b>7</b>	<b>8</b>	<b>9</b>	<b>10</b>	<b>11</b>
		<b>RFP Release</b>	<b>Source Selection</b>	<b>Requirements Review (RR)</b>	<b>Preliminary Design Review (PDR)</b>	<b>Critical Design Review (CDR)</b>	<b>Build Readiness Review (BRR)</b>	<b>Test Evaluation Campaign Review (TECR)</b>	<b>Baseline Integrated Systems Test (BIST)</b>	<b>Pre Environmental Review (PER)</b>	<b>Pre Ship Review (PSR)</b>	<b>Mission Readiness Review (MRR)</b>	<b>Flight Readiness Review (FRR)</b>	<b>Initial Checkout Review (CHR)</b>
	<ul style="list-style-type: none"> <li>Major areas of emphasis: 1) Key product/process characteristics; 2) Design and development management planning; 3) Customer and regulatory requirements; 4) Verification &amp; validation documentation and testing; 5) Documentation and data changes; 6) Supplier purchasing and subcontractor evaluation, data, and product verification; 7) First Article Inspection; 8) Inclusion of all inspection, measuring, and test equipment devices; 9) Nonconforming material review authority &amp; disposition; 10) Flow-down of corrective action to appropriate subcontractors; 11) Flow-down of the requirements from the quality manual to work instructions for use on internal quality audits; 12) Where servicing is a requirement, the procedure(s) will address specifics on data, technical documentation, repair schemes, and controls; and 13) Some statistical techniques are utilized to improve Design verification, Process Control, Inspection, FMEA, and Quality management.</li> </ul>													
<b>SYSTEM SAFETY ASSURANCE</b>														
1	<p>SSHP (System Safety &amp; Hazard Plan) [Includes Human Factors]</p> <ul style="list-style-type: none"> <li>This plan describes the procedures &amp; process used to identify potential hazards under all operating conditions of the system (or acts in developing the system). It also identifies the actions necessary to eliminate/control hazards or reduce the associated risk to an acceptable level.</li> <li>The order of precedence for system safety hazard control is: 1) Eliminate hazards through design selection/features; 2) Incorporate safety devices/warnings; 3) Develop procedures &amp; training.</li> </ul>			<b>C</b>	<b>U</b>	<b>B</b>	<b>R</b>	<b>F</b>	<b>F</b>	<b>F</b>	<b>F</b>	<b>F</b>	<b>F</b>	<b>F</b>



<b>Maturity Terminology</b>	<b>C = Created:</b> The initial generation or first draft of a Work Product being developed that is under author control and has not been reviewed.
	<b>U = Updated:</b> A Work Product that contains new information, remains under author or IPT control, and has completed an informal review process by peers.
	<b>B = Baseline:</b> A prepared or concluded Work Product that has been iterated, has IPT or Program Management acceptance, is ready for a formal Gated Event review, and may not be changed without formal CM revision control.
	<b>R = Revised:</b> A reevaluated work product that has been significantly modified, remains under CM control, and will require approval authority for changes to the technical baseline.
	<b>F = Finalized:</b> Brings a Work Product to its final state where it has been reviewed and/or signed off by the approval authority and is available to be used.

<b>Critical Gated Events Work Products</b>		<b>A</b>	<b>B</b>	<b>1</b>	<b>2</b>	<b>3</b>	<b>4</b>	<b>5</b>	<b>6</b>	<b>7</b>	<b>8</b>	<b>9</b>	<b>10</b>	<b>11</b>
		<b>RFP Release</b>	<b>Source Selection</b>	<b>Requirements Review (RR)</b>	<b>Preliminary Design Review (PDR)</b>	<b>Critical Design Review (CDR)</b>	<b>Build Readiness Review (BRR)</b>	<b>Test Evaluation Campaign Review (TECR)</b>	<b>Baseline Integrated Systems Test (BIST)</b>	<b>Pre Environmental Review (PER)</b>	<b>Pre Ship Review (PSR)</b>	<b>Mission Readiness Review (MRR)</b>	<b>Flight Readiness Review (FRR)</b>	<b>Initial Checkout Review (CHR)</b>
	<ul style="list-style-type: none"> <li>Additionally, hazardous and other safety critical procedures extend to LV and at the launch site when the SV and LV are integrated. The plan will include several safety analysis reports including: 1) Range Missile System Prelaunch Safety package; 2) Accident Risk Assessment Report; and 3) a Safety Compliance Data Package (for both Flight and Ground).</li> <li>Hazards and hazardous materials exist, and the plans/mitigations should be addressed to the following: flammables, toxic materials, propellants, corrosives, cryogenic fluids, asphyxiants, ordnance &amp; pyrotechnics, pressurized systems, mechanisms &amp; energy storage devices (springs, clamps tensioned cables), ionizing &amp; non-ionizing radiation sources (RF, lasers, etc.), transportation &amp; handling equipment, voltages above 30 VDC or 30 VAC.</li> </ul>													
2	Environmental Effects Plan (EEP) [EMI/EMC Plan, Radiation Effects, etc.] <ul style="list-style-type: none"> <li>To Be Supplied (TBS)</li> </ul>			C	U	B	R	F	F	F	F	F	F	F
3	Electro Static Discharge Plan (ESDP) [includes Spacecraft Charging, Power Distribution & <ul style="list-style-type: none"> <li>To Be Supplied (TBS)</li> </ul>			C	U	B	R	F	F	F	F	F	F	F
<b>DESIGN ASSURANCE</b>														
1	Hardware Development Plan (HDP) <ul style="list-style-type: none"> <li>Describes the electrical and mechanical design approach, the hardware configuration/product structure, the design tools CAD/CAE/CAM tools used, the modeling/simulation/analysis tools, and the design standards, specifications, and controls utilized.</li> <li>The plan describes two distinct phases: 1) Advanced development phase - that results in preliminary design specifications; and 2) design development phase - which culminates in a final, validated design.</li> </ul>			C	U	B	R	R	F	F	F	F	F	F

**Maturity Terminology**

**C = Created:** The initial generation or first draft of a Work Product being developed that is under author control and has not been reviewed.  
**U = Updated:** A Work Product that contains new information, remains under author or IPT control, and has completed an informal review process by peers.  
**B = Baselined:** A prepared or concluded Work Product that has been iterated, has IPT or Program Management acceptance, is ready for a formal Gated Event review, and may not be changed without formal CM revision control.  
**R = Revised:** A reevaluated work product that has been significantly modified, remains under CM control, and will require approval authority for changes to the technical baseline.  
**F = Finalized:** Brings a Work Product to its final state where it has been reviewed and/or signed off by the approval authority and is available to be used.

Critical Gated Events Work Products		A	B	1	2	3	4	5	6	7	8	9	10	11
		RFP Release	Source Selection	Requirements Review (RR)	Preliminary Design Review (PDR)	Critical Design Review (CDR)	Build Readiness Review (BRR)	Test Evaluation Campaign Review (TECR)	Baseline Integrated Systems Test (BIST)	Pre Environmental Review (PER)	Pre Ship Review (PSR)	Mission Readiness Review (MRR)	Flight Readiness Review (FRR)	Initial Checkout Review (CHR)
	<ul style="list-style-type: none"> <li>The process describes the iterative refinement taking into account dynamic modeling, detailed analysis, hardware development &amp; qualification testing, and final inputs into environmental and system specifications.</li> </ul>													
2	<b>Detail Drawings</b> <ul style="list-style-type: none"> <li>A drawing of a single part or unit that defines all features, including materials, finishes, supporting documents, etc. (e.g., chassis, bracket, stiffener, etc.)</li> <li>Dictates engineering and source inspection requirements for a particular item.</li> <li>After drawing release, any changes to the configuration are strictly controlled by CM and a rigorous change review board process is followed. An important consideration for all drawings is its effectivity and the final verification that the part has been built to its planned design configuration.</li> </ul>			C	U	B	R	R	F	F	F	F	F	F
3	<b>Assembly Drawings</b> <ul style="list-style-type: none"> <li>Pertains to two or more parts assembled into an integral unit. Includes the parts list and general notes.</li> <li>Includes the parts list and general notes, and encompasses the specification control and source control drawings.</li> </ul>				C	U	B	R	F	F	F	F	F	F
4	<b>Installation Drawings/Procedures</b> <ul style="list-style-type: none"> <li>Contains information for mounting a unit or assembly onto another part or structure.</li> <li>There are also special types of drawings such as layouts, tooling drawings, and general arrangement drawings showing the location of assemblies on the SV.</li> </ul>				C	U	B	R	F	F	F	F	F	F
5	<b>Schematics/Wiring Diagrams</b> <ul style="list-style-type: none"> <li>Provides detailed interconnection information (e.g. signal information) that defines point-to-point wire connectors/component/wiring intersections, bundling, and routing.</li> </ul>				C	U	B	R	F	F	F	F	F	F

**Maturity Terminology**

**C = Created:** The initial generation or first draft of a Work Product being developed that is under author control and has not been reviewed.  
**U = Updated:** A Work Product that contains new information, remains under author or IPT control, and has completed an informal review process by peers.  
**B = Baseline:** A prepared or concluded Work Product that has been iterated, has IPT or Program Management acceptance, is ready for a formal Gated Event review, and may not be changed without formal CM revision control.  
**R = Revised:** A reevaluated work product that has been significantly modified, remains under CM control, and will require approval authority for changes to the technical baseline.  
**F = Finalized:** Brings a Work Product to its final state where it has been reviewed and/or signed off by the approval authority and is available to be used.

Critical Gated Events Work Products		A	B	1	2	3	4	5	6	7	8	9	10	11
		RFP Release	Source Selection	Requirements Review (RR)	Preliminary Design Review (PDR)	Critical Design Review (CDR)	Build Readiness Review (BRR)	Test Evaluation Campaign Review (TECR)	Baseline Integrated Systems Test (BIST)	Pre Environmental Review (PER)	Pre Ship Review (PSR)	Mission Readiness Review (MRR)	Flight Readiness Review (FRR)	Initial Checkout Review (CHR)
	<ul style="list-style-type: none"> <li>Also includes mechanical information for manufacturing harnesses and installing them onto the SV.</li> </ul>													
6	<p>Worst-Case Design Analyses</p> <ul style="list-style-type: none"> <li>WCA demonstrates at EOL circuits will meet their intended function - for both application and the environment used.</li> <li>PMP reviews WCA report and certifies that all EEE parameter limits used are consistent with EOL deratings to satisfy stress limitation requirements (by incorporating margin).</li> <li>At CDR, a complete WCA must be provided for every circuit and a complete FMECA should examine every possible type of failure in the unit or subsystem. The worst-case conditions for any given circuit will be a combination of the extreme values of: 1) circuit interface inputs &amp; loads (voltage / time / frequency / temperature / quality-level); and 2) Piece part parameter variations.</li> </ul>			C	U	B	R	R	F	F	F	F	F	F
7	<p>STOP Analyses (Structural, Thermal, Optical, Performance)</p> <ul style="list-style-type: none"> <li>To Be Supplied (TBS)</li> </ul>			C	U	B	R	R	F	F	F	F	F	F
8	<p>Packaging, Handling, Storage &amp; Transportation (PHST) Plan</p> <ul style="list-style-type: none"> <li>To Be Supplied (TBS)</li> </ul>				C	U	B	R	F	F	F	F	F	F
<b>SOFTWARE ASSURANCE</b>														
1	Software Development Plan (SDP)			C	U	B	R	R	F	F	F	F	F	F

Maturity Terminology

**C = Created:** The initial generation or first draft of a Work Product being developed that is under author control and has not been reviewed.  
**U = Updated:** A Work Product that contains new information, remains under author or IPT control, and has completed an informal review process by peers.  
**B = Baseline:** A prepared or concluded Work Product that has been iterated, has IPT or Program Management acceptance, is ready for a formal Gated Event review, and may not be changed without formal CM revision control.  
**R = Revised:** A reevaluated work product that has been significantly modified, remains under CM control, and will require approval authority for changes to the technical baseline.  
**F = Finalized:** Brings a Work Product to its final state where it has been reviewed and/or signed off by the approval authority and is available to be used.

Critical Gated Events Work Products		A	B	1	2	3	4	5	6	7	8	9	10	11
		RFP Release	Source Selection	Requirements Review (RR)	Preliminary Design Review (PDR)	Critical Design Review (CDR)	Build Readiness Review (BRR)	Test Evaluation Campaign Review (TECR)	Baseline Integrated Systems Test (BIST)	Pre Environmental Review (PER)	Pre Ship Review (PSR)	Mission Readiness Review (MRR)	Flight Readiness Review (FRR)	Initial Checkout Review (CHR)
	<ul style="list-style-type: none"> <li>The SDP outlines the coordinated approach required on the Program defining all aspects of SW development such as: 1) SW Development Management; 2) SW Engineering &amp; Tools; 3) SW Testing; 4) SW Product Evaluations; 5) SW Configuration &amp; Data management; 6) SW Quality Assurance; 7) SW Architecture/identification of Configured Item SW elements; 8) SW Requirements &amp; Design; 9) SW Documentation; 10) SW Roles &amp; Responsibilities; 11) SW Coding Guidelines &amp; Debugging; 12) SW Reviews; 13) SW Milestones (Detailed requirements specification; Design specification &amp; coding; Design (logic path) &amp; function testing; Integration testing; Acceptance testing); and 14) SW COTS Implementation.</li> </ul>													
2	<p>Software Requirements Specification</p> <ul style="list-style-type: none"> <li>The system allocated baseline of lower-level SW configured items (CI's). This specification is also known as the B5 - SW Program Development specification.</li> <li>A design-to-specification that describes the requirements for a software product (logically stand's alone in identity &amp; function).</li> </ul>			C, U	B	R	R	R	F	F	F	F	F	F
3	<p>Software Manuals</p> <ul style="list-style-type: none"> <li>To Be Supplied (TBS)</li> </ul>				C	U	B	R	F	F	F	F	F	F
<b>MANUFACTURING ASSURANCE</b>														
1	Manufacturing Operating Plan (MOP)			C	U	B	R	R	F	F	F	F	F	F

<b>Maturity Terminology</b>	<b>C = Created:</b> The initial generation or first draft of a Work Product being developed that is under author control and has not been reviewed.
	<b>U = Updated:</b> A Work Product that contains new information, remains under author or IPT control, and has completed an informal review process by peers.
	<b>B = Baseline:</b> A prepared or concluded Work Product that has been iterated, has IPT or Program Management acceptance, is ready for a formal Gated Event review, and may not be changed without formal CM revision control.
	<b>R = Revised:</b> A reevaluated work product that has been significantly modified, remains under CM control, and will require approval authority for changes to the technical baseline.
	<b>F = Finalized:</b> Brings a Work Product to its final state where it has been reviewed and/or signed off by the approval authority and is available to be used.

<b>Critical Gated Events Work Products</b>		<b>A</b>	<b>B</b>	<b>1</b>	<b>2</b>	<b>3</b>	<b>4</b>	<b>5</b>	<b>6</b>	<b>7</b>	<b>8</b>	<b>9</b>	<b>10</b>	<b>11</b>
		<b>RFP Release</b>	<b>Source Selection</b>	<b>Requirements Review (RR)</b>	<b>Preliminary Design Review (PDR)</b>	<b>Critical Design Review (CDR)</b>	<b>Build Readiness Review (BRR)</b>	<b>Test Evaluation Campaign Review (TECR)</b>	<b>Baseline Integrated Systems Test (BIST)</b>	<b>Pre Environmental Review (PER)</b>	<b>Pre Ship Review (PSR)</b>	<b>Mission Readiness Review (MRR)</b>	<b>Flight Readiness Review (FRR)</b>	<b>Initial Checkout Review (CHR)</b>
	<ul style="list-style-type: none"> <li>This plan describes the approach used for all "make decisions" from a "make vs buy" analysis. The following areas are addressed: 1) Producibility of product design; 2) Production capacity analyzed &amp; demonstrated; 3) Availability of production equipment, tooling &amp; certified personnel; 4) Production plan synchronized with delivery requirements; 5) Critical processes identified, qualified, &amp; documented; 6) Engineering Drawings, Build History Planning Instructions/Work Orders, Process specifications, &amp; Test Procedures released; 7) Quality Assurance Inspection/Workmanship criteria documented; 8) MRB &amp; FRB processing documented, 9) Engineering BOM &amp; Manufacturing BOM deconflicted; 10) All Flight Parts &amp; Kitting required to support production demand are available &amp; qualified (including GIDEPS), 11) GSE, Production Tooling &amp; Tools certified/calibrated/proof-loaded, and 12) Facility is certified (N2, Dry Air, ESD &amp; Grounding, Particle counts, Hazardous Waste Handling &amp; Disposal, Safety/Hazard analysis completed).</li> </ul>													
2	<ul style="list-style-type: none"> <li>Producibility Plan</li> <li>Specifically addresses the "manufacturability &amp; assembleability" of the product using the following techniques/rules of thumb: 1) Simplify/Minimize number of parts; 2) Develop modular designs; 3) Use standard parts &amp; materials; 4) Minimize part variations/part numbers; 5) Design parts with self-locating features, 6) Error-proof product design &amp; assembly.</li> </ul>			<b>C, U</b>	<b>B</b>	<b>R</b>	<b>F</b>	<b>F</b>	<b>F</b>	<b>F</b>	<b>F</b>	<b>F</b>	<b>F</b>	<b>F</b>
3	<ul style="list-style-type: none"> <li>Production Plan &amp; Master Production Schedule (Capacity &amp; Throughput Analysis)</li> </ul>			<b>C</b>	<b>U</b>	<b>B</b>	<b>R</b>	<b>F</b>	<b>F</b>	<b>F</b>	<b>F</b>	<b>F</b>	<b>F</b>	<b>F</b>

<b>Maturity Terminology</b>	<b>C = Created:</b> The initial generation or first draft of a Work Product being developed that is under author control and has not been reviewed.
	<b>U = Updated:</b> A Work Product that contains new information, remains under author or IPT control, and has completed an informal review process by peers.
	<b>B = Baseline:</b> A prepared or concluded Work Product that has been iterated, has IPT or Program Management acceptance, is ready for a formal Gated Event review, and may not be changed without formal CM revision control.
	<b>R = Revised:</b> A reevaluated work product that has been significantly modified, remains under CM control, and will require approval authority for changes to the technical baseline.
	<b>F = Finalized:</b> Brings a Work Product to its final state where it has been reviewed and/or signed off by the approval authority and is available to be used.

<b>Critical Gated Events Work Products</b>		<b>A</b>	<b>B</b>	<b>1</b>	<b>2</b>	<b>3</b>	<b>4</b>	<b>5</b>	<b>6</b>	<b>7</b>	<b>8</b>	<b>9</b>	<b>10</b>	<b>11</b>
		<b>RFP Release</b>	<b>Source Selection</b>	<b>Requirements Review (RR)</b>	<b>Preliminary Design Review (PDR)</b>	<b>Critical Design Review (CDR)</b>	<b>Build Readiness Review (BRR)</b>	<b>Test Evaluation Campaign Review (TECR)</b>	<b>Baseline Integrated Systems Test (BIST)</b>	<b>Pre Environmental Review (PER)</b>	<b>Pre Ship Review (PSR)</b>	<b>Mission Readiness Review (MRR)</b>	<b>Flight Readiness Review (FRR)</b>	<b>Initial Checkout Review (CHR)</b>
	• Not the Program IMS, but the MRP (Materials Requirements Planning)/ERP (Enterprise Requirements Planning) high-level schedule that takes into account rough-cut capacity planning and inventory/safety stock of available parts - once exploded down to its lowest-level of detail.													
4	Build History Planning/Work Orders • To Be Supplied (TBS)			C	U	B	R	F	F	F	F	F	F	F
5	Kitting & Parts Status Plan • To Be Supplied (TBS)			C	U	B	R	F	F	F	F	F	F	F
6	Facilities/Space Plan (FSP) • To Be Supplied (TBS)			C	U	B	R	F	F	F	F	F	F	F
7	Manufacturing Facility Certification • To Be Supplied (TBS)				C, U	B	R	F	F	F	F	F	F	F
8	Skills Training & Certification Matrix • To Be Supplied (TBS)					C, U	B	R	R	R	F	F	F	F
9	GSE/STE/Tooling Certified/Calibrated/Proof-Loaded/PM Matrix • To Be Supplied (TBS)					C, U	B	R	R	R	F	F	F	F
<b>INTEGRATION, TEST &amp; EVALUATION</b>														
1	Test Requirements Specification (TRS) • To Be Supplied (TBS)			C	U	U	B	R	F	F	F	F	F	F
2	Environmental Test Requirements Specification (ETRS) • To Be Supplied (TBS)			C	U	U	B	R	F	F	F	F	F	F
3	GSE/STE ICD (Mech/Elect/Optical/Thermal) • To Be Supplied (TBS)			C, U	B	R	R	F	F	F	F	F	F	F
4	Embedded Test (BIT)/Integrated Diagnostics /DFT Requirements • To Be Supplied (TBS)			C	U	U	B	R	F	F	F	F	F	F
5	GSE/STE FMEA Analysis • To Be Supplied (TBS)				C	U	B	R	F	F	F	F	F	F

**Maturity Terminology**

**C = Created:** The initial generation or first draft of a Work Product being developed that is under author control and has not been reviewed.  
**U = Updated:** A Work Product that contains new information, remains under author or IPT control, and has completed an informal review process by peers.  
**B = Baseline:** A prepared or concluded Work Product that has been iterated, has IPT or Program Management acceptance, is ready for a formal Gated Event review, and may not be changed without formal CM revision control.  
**R = Revised:** A reevaluated work product that has been significantly modified, remains under CM control, and will require approval authority for changes to the technical baseline.  
**F = Finalized:** Brings a Work Product to its final state where it has been reviewed and/or signed off by the approval authority and is available to be used.

Critical Gated Events Work Products		A	B	1	2	3	4	5	6	7	8	9	10	11
		RFP Release	Source Selection	Requirements Review (RR)	Preliminary Design Review (PDR)	Critical Design Review (CDR)	Build Readiness Review (BRR)	Test Evaluation Campaign Review (TECR)	Baseline Integrated Systems Test (BIST)	Pre Environmental Review (PER)	Pre Ship Review (PSR)	Mission Readiness Review (MRR)	Flight Readiness Review (FRR)	Initial Checkout Review (CHR)
6	GSE/STE Metrology Plan • To Be Supplied (TBS)				C	U	B	R	F	F	F	F	F	F
7	Test & Evaluation Master Plan (TEMP) [includes Design-for-Test; BIT testing] • To Be Supplied (TBS)			C	U	U	U	B	F	F	F	F	F	F
8	Top-Level Test Configuration Drawing • To Be Supplied (TBS)				C	U	B	R	F	F	F	F	F	F
9	Thermal Vacuum Test Plan • To Be Supplied (TBS)			C	U	B	R	R	F	F	F	F	F	F
10	EMI/EMC Test Plan • To Be Supplied (TBS)			C	U	B	R	R	F	F	F	F	F	F
11	Vibration, Shock & Acoustics Test Plan • To Be Supplied (TBS)			C	U	B	R	R	F	F	F	F	F	F
12	Mass Properties Test Plan • To Be Supplied (TBS)			C	U	B	R	R	F	F	F	F	F	F
13	Test Scripts/Recipes • A set of coded instructions that are interpreted by a SW test environment to command a simulator, emulator, or both to execute in a specific manner to test SW and HW. • The use of test scripts allows test activities to be conducted in an automated manner without a tester being present, around the clock, and remotely.				C	U	B	R	R	F	F	F	F	F
14	Test Procedures – Electrical (Functional) • The documents that implement the testing of the System Test Plan or the Test Evaluation Master Plan (TEMP) by identifying the sequential tasks and data that must be accumulated by test personnel, for the purpose of verifying an individual test case allocated to a requirement. It defines the step-by-step testing sequence, test equipment used, calibration requirements, test facility requirements, etc.				C	U	B	R	R	F	F	F	F	F

**Maturity Terminology**

**C = Created:** The initial generation or first draft of a Work Product being developed that is under author control and has not been reviewed.  
**U = Updated:** A Work Product that contains new information, remains under author or IPT control, and has completed an informal review process by peers.  
**B = Baseline:** A prepared or concluded Work Product that has been iterated, has IPT or Program Management acceptance, is ready for a formal Gated Event review, and may not be changed without formal CM revision control.  
**R = Revised:** A reevaluated work product that has been significantly modified, remains under CM control, and will require approval authority for changes to the technical baseline.  
**F = Finalized:** Brings a Work Product to its final state where it has been reviewed and/or signed off by the approval authority and is available to be used.

Critical Gated Events Work Products		A	B	1	2	3	4	5	6	7	8	9	10	11
		RFP Release	Source Selection	Requirements Review (RR)	Preliminary Design Review (PDR)	Critical Design Review (CDR)	Build Readiness Review (BRR)	Test Evaluation Campaign Review (TECR)	Baseline Integrated Systems Test (BIST)	Pre Environmental Review (PER)	Pre Ship Review (PSR)	Mission Readiness Review (MRR)	Flight Readiness Review (FRR)	Initial Checkout Review (CHR)
	<ul style="list-style-type: none"> <li>Basic electrical interface verification and functional tests are performed to verify signal and power paths.</li> <li>Electrical testing ranges all the way from the individual component level, to the SV, and finally up to the combined SV-LV-Ground integrated System.</li> <li>Examples include: Safe-to-Mate/Safe-to-Power-up/Aliveness test/Functional electrical test.</li> </ul>													
15	Test Procedures – RF • To Be Supplied (TBS)				C	U	B	R	R	F	F	F	F	F
16	Test Procedures – Optical • To Be Supplied (TBS)				C	U	B	R	R	F	F	F	F	F
17	Test Procedures – Thermal Vacuum • To Be Supplied (TBS)				C	U	B	R	R	F	F	F	F	F
18	Test Procedures – Thermal Balance • To Be Supplied (TBS)				C	U	B	R	R	F	F	F	F	F
19	Test Procedures – Vibration/Shock • To Be Supplied (TBS)				C	U	B	R	R	F	F	F	F	F
20	Test Procedures – Acoustic • To Be Supplied (TBS)				C	U	B	R	R	F	F	F	F	F
21	Test Procedures – Mass Properties • To Be Supplied (TBS)				C	U	B	R	R	F	F	F	F	F
22	Test Lab Certification • To Be Supplied (TBS)				C	U	B	F	F	F	F	F	F	F
23	Test Verification Reports • To Be Supplied (TBS)						C	B	R	R	F	F	F	F
24	User Guides/Test Manuals • To Be Supplied (TBS)							C	B	R	F	F	F	F
<b>OPERATIONAL READINESS ASSURANCE</b>														
1	Pre-Launch DD-250												F	F



**Maturity Terminology**

**C = Created:** The initial generation or first draft of a Work Product being developed that is under author control and has not been reviewed.

**U = Updated:** A Work Product that contains new information, remains under author or IPT control, and has completed an informal review process by peers.

**B = Baseline:** A prepared or concluded Work Product that has been iterated, has IPT or Program Management acceptance, is ready for a formal Gated Event review, and may not be changed without formal CM revision control.

**R = Revised:** A reevaluated work product that has been significantly modified, remains under CM control, and will require approval authority for changes to the technical baseline.

**F = Finalized:** Brings a Work Product to its final state where it has been reviewed and/or signed off by the approval authority and is available to be used.

Critical Gated Events Work Products		A	B	1	2	3	4	5	6	7	8	9	10	11
		RFP Release	Source Selection	Requirements Review (RR)	Preliminary Design Review (PDR)	Critical Design Review (CDR)	Build Readiness Review (BRR)	Test Evaluation Campaign Review (TECR)	Baseline Integrated Systems Test (BIST)	Pre Environmental Review (PER)	Pre Ship Review (PSR)	Mission Readiness Review (MRR)	Flight Readiness Review (FRR)	Initial Checkout Review (CHR)
	• To Be Supplied (TBS)													
2	Flight Worthiness Certification by Launch Authority • To Be Supplied (TBS)										C	B	F	F
3	Aerospace Launch Verification Letter • To Be Supplied (TBS)												F	F
4	EOT Report • To Be Supplied (TBS)													F
5	SCA Change Notice • To Be Supplied (TBS)													F



## 15. Acronymns and Abbreviations

AT	Acceptance test
BIST RR	Baseline integrated system test readiness review
BRR	Build Readiness Review
CA	Corrective action
CDR	Critical design review
CM	Configuration management
COMSEC	Communication security
CONOPS	Concept of operations
COTS	Commercial off-the-shelf
CPIF	Cost-plus-incentive fee
DFT	Design for test
DFT	Design for testability
DVT	Design verification test
EDU	Engineering Development Units (i.e., engineering models)
EGSE	Electrical ground support equipment
EMI	Electromagnetic interference
EN	Evaluation notice
ESD	Electro-static discharge
FA	Failure Analysis
FMEA	Finite element analysis
FPR	Final price review
FRACAS	Failure Review and Corrective Action System
FRB	Failure review board
FRR	Flight readiness review
GFE	Government furnished equipment
GSE	Ground support equipment
HWCI	Hardware configuration item
ICD	Interface control document
ICR	Initial Checkout Review
LRR	Launch Readiness Review
LVDC	Launch Vehicle Data Center
MA	Mission assurance
MDC	Mission Directors Center
MGSE	Mechanical ground support equipment
MHE	Material handling equipment
MRR	Mission Readiness Review
PSA	Parts stress analysis
PDR	Preliminary Design Review
PER	Pre-Environmental Review
PSR	Pre-ship Review
QT	Qualification test
RFP	Request for proposal
RR	Requirements Review
RVP	Requirement verification plan
SQIC	Space Quality Improvement Council
SRR	System Requirements Review
TECR	Test Evaluation Campaign Review
TLYF	Test like you fly

TRL	Technology readiness level
TRR	Test Readiness Review
TRS	Test requirement specifications
TT&C	Telemetry, tracking, and command
UVF	Unverified failure
VCRM	Verification cross-reference matrix

## Appendix: Suggestions for Improving RFPs and Source Selection Process

### 1. Contractor A Input:

**Prevent Deviations from Established Acquisition Baselines** - First and foremost, once a new opportunity has been announced, the scope of the acquisition has been defined, and an acquisition schedule has been established, do not deviate from it. For example, TSAT and GPS III are acquisitions that have had several course corrections extending each acquisition by years. This drew out proposal cycles and resulted in significant waste of bid and proposal dollars, which is ultimately a waste of taxpayer dollars. In the case of GPS III, the acquisition spanned more than eight years and ultimately resulted in a very similar space segment program to that proposed in the first year of the acquisition, while competition for the control segment is still taking place.

Had the government chosen to stay the initial course, the source selection could have been based on the established requirements for GPS III, with the proposals evaluated against the baseline performance/cost/schedule requirements, and the award presented to the most credible bidder. Subsequent changes to the baseline could then have been worked in an Alpha (shoulder-to-shoulder) contracting relationship and changed to reflect current government stakeholder requirements.

If this recommendation is not implementable, an alternative approach would be to prevent issuing any draft RFP items, or announcing that an acquisition is imminent, until a set of requirements has been approved by the JROC and other governing boards, and an acquisition plan has been approved by DOD. The problem with GPS and TSAT was that solicitation information was released before requirements were final, initiating many false starts by contractors.

**Collaborative RFP Development Approach** - Consider employing a more collaborative approach (shoulder-to-shoulder-like) in RFP development, particularly Sections L (Proposal Preparation Instructions) and M (Evaluation Criteria) from the beginning of the acquisition. Other areas to be discussed could be WBS structure, IMS requirements, cost model details, and BOE specifics, as well as an explanation of the government's expectations. Such an approach would help eliminate misunderstandings between the government and contractor in terms of expectations for what is required to be compliant and/or evaluated to be at least successful. These misunderstandings of what the customer is really seeking ultimately cause frustration in the evaluation cycle, lead to a significant number of evaluation notices (ENs), and eliminate any chance for the customer to award without discussion.

This approach might appear to conflict with the first suggestion in that it would cost more money. However, the argument should be that early and continuous collaboration would cost less overall because all proposal expectations would be understood and less rework would be needed. This collaboration would include information about the requirements and acquisition plan approval process (see my comments to 1) so contractors would not move too far ahead in their proposal development until they knew the approved requirements set and acquisition plan.

**Release Complete Draft RFPs** - Consider holding draft RFPs until a complete and consistent document, including attachments, is available for release. Typically, draft Sections L and M are released early while other compliance documents, such as performance specifications, statements of work, technical requirements documents, and statements of objectives are still being drafted. This often leads to inconsistencies among the documents that can result in inconsistencies in the proposal responses.

This suggestion is related to the first recommendation. The rush to release portions of an RFP often has contractors moving ahead before the final RFP requirements and acquisition plan have been approved, resulting in extensive work that must be redone for the final acquisition.

**Reasonable Page Count Allocations** - Consider making a more deliberate effort to ensure that requirements and criteria set forth in Sections L and M are accommodated for, with appropriate page allocations. All too often, the government seeks to obtain an in-depth understanding of how contractors will meet/achieve requirements or deliver products with high confidence, yet does not allocate sufficient proposal pages to enable contractors to respond adequately. This is one area where a collaborative approach to developing and understanding expectations established in Sections L and M could help both the government and the contractor to be successful.

**Develop Acquisition-Specific RFPs** - Consider writing RFPs (especially Sections L and M, which are specific to the opportunity being competed), and establish appropriate page allocations therein. For example, several recent RFPs from SMC, contained identical Sections L and M, even though the opportunities were of distinct and significantly varying value. In addition, ensure appropriate time is allocated for contractor proposal development. Aspects such as size of proposal requested and number of subcontracts required should be considered when deciding proposal due dates. However, the longer the response period, the more costly for the contractor and government. Size the response time appropriately for the program requirements.

**Industry Day After RFP Release** - Consider holding an industry day *after* final RFP release (and contractor review period) to review Section L instructions, explain/review attached Excel templates for reporting cost data in the cost volume, and review expectations for meeting performance requirements stated in attachments to the RFP.

**Open Communication During EN/Final Price Review (FPR) Cycles** - Consider using the GPS III EN/FPR approach on all competitive procurements. The GPS III Source Selection Evaluation Team (SSET) released ENs allowing competitors to incrementally submit responses prior to the deadline, resulting in an early review and comment by the SSET. This enabled the government to achieve a better, more complete understanding of each offer and enabled competitors the opportunity to ensure all questions, weaknesses, and deficiencies were answered to the government's satisfaction.

## **2. Contractor B Input:**

Three areas negatively impact the acquisition phase:

- Insufficient budget
- Immature requirements
- Profit structure that provides insufficient motivation to the contractor

### Budget

Ideally, government program managers should have sufficient budget flexibility to permit the judicious use of reserves to solve problems during program execution. Additionally, sufficient funding would allow prime contractors to fully fund and adequately manage the subcontractors. Regrettably, there has been insufficient budget flexibility with too little margin reserve on a number of programs. The problem is exacerbated by contractors that tend to submit overly optimistic budget estimates to support government budget exercises. Later in the process, contractors will tend to submit optimistic price proposals, seeking to win programs. Sufficient budget must be allotted to provide for margin reserve.

### Requirements Definition

Stakeholders in the government often advocate early program starts before the technology matures. As a result, years are often spent developing a technology as part of the acquisition while significant costs are expended to maintain a large acquisition army. Critical technologies should be developed to sufficient maturity to reduce the risk of surprises during the later stages of the acquisition cycle. Notwithstanding the fact that technologies are immature, the stakeholders also desire detailed specification requirements which allows little flexibility for technical solutions. Program immaturity coupled with detailed requirements drive costs. The RFP should only define the performance attributes necessary to accomplish the mission; not the detailed requirements. The presence of detailed requirements in the RFP inhibits requirements flow down during the first few months of program execution. In addition to performance requirements at the prime contract level, the RFP should be structured to encourage prime contractors to expeditiously allocate and flow down performance requirements for the subsystems to be designed and built by subcontractors.

### Profit Structures

Adequate requirements definition and budget will facilitate profit structures that will appropriately incentivize contractors to provide optimal internal investments and resources to the job. Contractors respond to incentives. It is recognized that incentive structures must be tailored to each program circumstance. The RFP should be structured in a manner that provides balance between incentives and penalties (particularly on-orbit). Further, there needs to be a balance between earnings opportunities from on-orbit performance with other performance/cost phases. Ideally, the contract arrangement should allow for: a) proper utilization of cost incentives in conjunction with performance incentives; b) a relatively defined baseline; and c) sufficient funding. Such an arrangement should provide the contractor the tools to effectively manage in-house effort and fully fund/manage the subcontractors. There appears to be a perception among government agencies that cost incentives allowing the contractor a portion of the underrun would lead the contractor away from strong technical performance. The RFP should be structured in a manner that recognizes that contractors will expend capital and resources on programs generating the greatest reward. Accordingly, cost incentives that provide the contractor with a reward for managing costs within target will result in controlled costs *and* successful technical performance.

The interrelationship between adequate budget and the contract arrangement cannot be overemphasized. As an example, on incrementally funded cost-plus-incentive fee (CPIF) programs in which budget pressures result in insufficient funding and/or the imposition of expenditure constraints, the contractor has little latitude to take the necessary steps to control costs below target. Conversely, where sufficient funding is provided, the contractor had the ability to effectively manage the program and fully fund the subcontractors. As a result, the opportunity for performance on or below budget and on schedule is greatly enhanced.





**INTERNAL DISTRIBUTION LIST**

REPORT TITLE

Guidelines for Space Systems Critical Gated Events

REPORT NO.

TOR-2009(8583)-8545

PUBLICATION DATE

09 May 08

SECURITY CLASSIFICATION

Unclassified

1. FOR OFF-SITE PERSONNEL, SHOW LOCATION SYMBOL, e.g., JOHN Q. PUBLIC/VAFB

2. IF LIST IS ALTERED, INITIAL CHANGE(S) AND SHOW AFFILIATION  
\*FOR SECRET REPORTS, SHOW BLDG AND ROOM, NOT MAIL STATION

**NAME (Include Initials)**

**MAIL CODE\***

**NAME (Include Initials)**

**MAIL CODE\***

A. L. Amram M8/085  
 D. G. Arbiter CH3/230  
 B. L. Arnheim M5/641  
 D. W. Bart M5/564  
 V. C. Boles CH1/510  
 M. L. Bolla M4/905  
 M. A. Brosmer M5/665  
 B. W. Chau CH1/520  
 P. G. Cheng M4/905  
 G. A. Davis CH1/520  
 M. De Ponte CH1/610  
 A. J. Dhallin M6/203  
 R. L. Donnelly CH2/130  
 G. S. Dudley CH2/220  
 R. J. Duphilly M4/905  
 J. P. Duggan CH2/220  
 B.Z. Faught M1/025  
 R. H. Fisher ROS  
 T. A. Freitag M1/043  
 R. P. Frueholz M1/933  
 T. E. Gallini M4/956  
 A. A. Geiger CH2/220  
 M. H. Goodman M1/016  
 W. H. Goodman M8/219  
 A. T. Guillen M5/584  
 S. S. Gustafson M5/664  
 D. J. Gorney M1/004  
 S. A. Guarro M4/905  
 T. R. Haas CH1/610  
 D. L. Hamme CH1/610

W. H. Hiatt CH3/310  
 K. G. Holden M5/131  
 R. F. Johnson M1/586  
 G. A. Johnson-Roth M4/905  
 J. B. Juranek M4/987  
 R. L. Kendall M1/587  
 F. L. Knight M5/564  
 J. D. Lang CH3/230  
 V. I. Lang M5/560  
 R. Lewis M4/929  
 A. C. Liang M4/945  
 R. M. Lollock M5/687  
 S. S. Matsunaga M5/565  
 R. McKenna CH1/410  
 A. R. Miller CH1/510  
 R. J. Minnichelli M8/692  
 S. Nagano M6/213  
 L. B. Peresztegy M5/564  
 D. A. Plunkett M1/165  
 J. P. Roberts M1/562  
 J. L. Roche CH2/406  
 M. N. Rochlin ROS  
 G. L. Schipper M1/562  
 B. E. Shaw M5/564  
 D. J. Speece M4/987  
 C. J. Steele COS/1200  
 J. A. Strada CH2/401  
 W. F. Tosney M6/203  
 R. K. Villalobos M6/203  
 J. R. Wormington M1/401  
 J. D. White M6/203

*FINAL APPROVER DRAW LINE(S) ACROSS UNFILLED SPACE AND INITIAL TO PRECLUDE ADDITIONS*

APPROVED \_\_\_\_\_

DATE \_\_\_\_\_

IF LIST COMPRISES TWO OR MORE SHEETS, COMPLETE ABOVE BLOCK ON LAST SHEET ONLY

**INTERNAL DISTRIBUTION LIST**

REPORT TITLE

**Guidelines for Space Systems Critical Gated Events**

REPORT NO.

**TOR-2009(8583)-8545**

PUBLICATION DATE

**09 May 08**

SECURITY CLASSIFICATION

**Unclassified**

1. FOR OFF-SITE PERSONNEL, SHOW LOCATION SYMBOL, e.g., JOHN Q. PUBLIC/AFB

2. IF LIST IS ALTERED, INITIAL CHANGE(S) AND SHOW AFFILIATION  
\*FOR SECRET REPORTS, SHOW BLDG AND ROOM, NOT MAIL STATION

**NAME (Include Initials)**

**MAIL CODE\***

**NAME (Include Initials)**

**MAIL CODE\***

M. J.	Wheaton	M4/161
J. R.	Witz	M5/584
F. E.	Younge	M1/562
S. L.	Zacharius	M2/264
K. P.	Zondervan	M5/649
<	AOLIB (2, 2740, 132, DB)	M1/199

*FINAL APPROVER DRAW LINE(S) ACROSS UNFILLED SPACE AND INITIAL TO PRECLUDE ADDITIONS*

APPROVED	<i>William J. Tourey</i>	DATE <b>24-OCT-08</b>
----------	--------------------------	-----------------------

IF LIST COMPRISES TWO OR MORE SHEETS, COMPLETE ABOVE BLOCK ON LAST SHEET ONLY

**EXTERNAL DISTRIBUTION LIST**

REPORT TITLE

**Guidelines for Space Systems Critical Gated Events**

REPORT NO.

**TOR-2009(8583)-8545**

PUBLICATION DATE

**09 May 2008**

SECURITY CLASSIFICATION

**Unclassified**

MILITARY AND GOVERNMENT OFFICES

ASSOCIATE CONTRACTORS AND OTHERS

1. SHOW FULL MAILING ADDRESS: INCLUDE ZIP CODE, MILITARY OFFICE SYMBOL, AND "ATTENTION" LINE.  
 2. IF LIST IS ALTERED, INITIAL CHANGE(S) AND SHOW AFFILIATION.

ATK  
 9160 N. Highway 83  
 Corinne, UT 84307  
 Attention: Stan Graves

Ball Aerospace & Technologies Corporation  
 1600 Commerce Street  
 Building RA-5  
 Boulder, CO 80301  
 Attention: Sherri Fike  
 Paula Greene

The Boeing Company  
 2260 E. Imperial Hwy  
 El Segundo, CA 90245  
 Attention:  
 Stan Albrecht - S10/S303  
 Rebecca Ashley - S10/S356  
 Eva Carrillo - S10/356  
 Andrew King S10-512  
 Kim Levine - S10/356  
 Michelle Matsuoka - S10/512  
 Jim Schultz - S10/303

The Boeing Company  
 2201 Seal Beach Boulevard, MC 110-SA42  
 Seal Beach, CA 90740-1515  
 Mr. Jack Murphy

General Dynamics  
 1440 North Fiesta Boulevard  
 Gilbert, AZ 85233  
 Attention: Mr. Kerry Wesley

Lockheed Martin Space Systems Company  
 12257 South Wadsworth Blvd  
 Littleton, CO 80125  
 Attention:  
 Dennis Deal  
 Helen Gjerde  
 Louise Ladow  
 Berry Paterson  
 Barbara Sande  
 Dave Shelton

Space Systems/Loral  
 3825 Fabian Way, MS G-80  
 Palo Alto, CA 94303  
 Attention: Robert McFarland

National Reconnaissance Office  
 14675 Lee Rd.  
 Chantilly, VA 20151-1715  
 Attention:  
 Lt. Col Blackman  
 Tom Burns  
 Richard Fink  
 Steve Schlonski

**FINAL APPROVER DRAW LINE(S) ACROSS UNFILLED SPACE AND INITIAL TO PRECLUDE ADDITIONS**

DISTRIBUTION LIMITATIONS MARKED ON THE COVER/TITLE PAGE ARE AUTHORIZED BY SIGNATURE BELOW

APPROVED \_\_\_\_\_ DATE \_\_\_\_\_  
 (AEROSPACE)

APPROVED BY \_\_\_\_\_ DATE \_\_\_\_\_  
 (AF OFFICE) (NOT REQUIRED FOR ATR CATEGORY)

IF LIST COMPRISES TWO OR MORE SHEETS, COMPLETE ABOVE BLOCK ON LAST SHEET ONLY

**EXTERNAL DISTRIBUTION LIST**

REPORT TITLE

**Guidelines for Space Systems Critical Gated Events**

REPORT NO.

**TOR-2009(8583)-8545**

PUBLICATION DATE

**09 May 2008**

SECURITY CLASSIFICATION

**Unclassified**

MILITARY AND GOVERNMENT OFFICES

ASSOCIATE CONTRACTORS AND OTHERS

1. SHOW FULL MAILING ADDRESS: INCLUDE ZIP CODE, MILITARY OFFICE SYMBOL, AND "ATTENTION" LINE.
2. IF LIST IS ALTERED, INITIAL CHANGE(S) AND SHOW AFFILIATION.

Northrop Grumman  
 One Space Park  
 Redondo Beach, CA 90278  
 Attention:  
 William Bjorndahl E2/5000  
 Dan Jarmel M3/2037  
 Bill McMullen E2/5063  
 Sonya Sepahban E2/5000  
 Craig Wesser E2/7051

Orbital Sciences Corporation  
 3380 South Price Road  
 Chandler, AZ 85248  
 Attention:  
 Charlie Whitmeyer  
 Barry Johnson

Raytheon  
 2000 E El Segundo Blvd  
 El Segundo CA 90245  
 Attention:  
 Susan Sloan EO/E01/C181  
 Emily Friedman EO/E01/C181  
 Charles Kelly EO/E01/F170  
 Andrew Traum EO/E01/C181

Space and Missile Systems Center  
 Air Force Space Command  
 483 N. Aviation Blvd.  
 El Segundo, CA 90245-2808  
 Attention:  
 Col. David Swanson (SMC/EA)  
 Mr. Jim Horesji (SMC/PIC)  
 Mr. Tom Fitzgerald (SMC/PI)  
 Lt. Col. John Varljen (SMC/PI)  
 Mr. Dave Davis (SMC/EAE)  
 Mr. Alejandro Levi (SMC/SS)

**FINAL APPROVER DRAW LINE(S) ACROSS UNFILLED SPACE AND INITIAL TO PRECLUDE ADDITIONS**

DISTRIBUTION LIMITATIONS MARKED ON THE COVER/TITLE PAGE ARE AUTHORIZED BY SIGNATURE BELOW	
APPROVED (AEROSPACE)	DATE <b>24 Oct 08</b>
APPROVED BY (AF OFFICE)	DATE <b>24 Oct 08</b>
<small>(NOT REQUIRED FOR ATR CATEGORY)</small>	

IF LIST COMPRISES TWO OR MORE SHEETS, COMPLETE ABOVE BLOCK ON LAST SHEET ONLY