



***PHYSICAL SCIENCES LABORATORIES
AT THE AEROSPACE CORPORATION***

Pg. 3	PSL Overview	Pg. 29	Space Domain Awareness
Pg. 5	Accelerated Microelectronics	Pg. 30	Space Environmental Effects
Pg. 6	Additive Manufacturing	Pg. 31	Space Photovoltaics
Pg. 7	AeroTel	Pg. 32	Space Sensors
Pg. 8	Atomic Clocks	Pg. 33	Thin Films and Optical Coatings
Pg. 9	Composites	Technology Highlights	
Pg. 10	Directed Energy	Pg. 35	Anomaly Attribution Tool Suite
Pg. 11	Electric Propulsion	Pg. 36	Battery Deorbiter
Pg. 12	Environmental Testing	Pg. 37	Catcher
Pg. 13	Fiber Laser Development Lab	Pg. 38	Micro Charged Particle Telescope (μ CPT)
Pg. 14	Free-Space Laser Applications	Pg. 39	Monocle
Pg. 15	Hyperspectral Imaging	Pg. 40	Phenomenology Imager & Nighttime Observer (PIANO)
Pg. 16	Laser Beacon	Pg. 41	pLEO Beacon
Pg. 17	Microelectronics		
Pg. 18	Micropropulsion		
Pg. 19	Non-Destructive Evaluation		
Pg. 20	Optical Communications		
Pg. 21	Optical Signal Processing		
Pg. 22	Propulsion Research Facility		
Pg. 23	Quantum Photonics		
Pg. 24	Radiation Effects		
Pg. 25	Replicated Optics		
Pg. 26	RF Breakdown (Multipactor)		
Pg. 27	Space Batteries		
Pg. 28	Spacecraft Contamination		



PHYSICAL SCIENCES LABORATORIES

The space enterprise is congested, contested, and growing at an unprecedented rate. Shorter acquisition timelines, increased proliferation of space assets, and an elevation of the space domain in national security have created a need for greater agility in development, procurement, fielding, and operating of systems to meet these new demands. Implementation of new, science-based, technologies and methodologies is imperative to making the leap to the next era in space. The Aerospace Physical Sciences Laboratories (PSL) provide the robust and innovative physical research backplane to achieve that implementation.



PSL's scientific impact is sustained and grown via a diverse research portfolio. Our work blends foundational scientific expertise with cutting-edge research to serve a broad customer base. PSL's exclusive ability to work with all stakeholders: (government, industry, and academia) enables us to provide novel solutions to the most challenging issues in current and future technologies. The strength of PSL comes from the combination of cutting-edge tools and facilities, a vast repository of space-system knowledge, and the extensive technical expertise of our people.

We harness these tools and expertise in 156 different laboratories to tackle the new challenges within the space enterprise. All PSL laboratories, capabilities, and personnel are aligned around four focus areas, each designed to tackle the new challenges of the space enterprise: Technology Development and Prototyping, Rapid and Agile Acquisitions, Resiliency and Space Warfighting R&D, Advanced Concepts.

PSL by the numbers:

- › Over 250 employees
- › Over 70% of technical staff have post-graduate degrees
- › Disciplines of Technical Staff:

Physics:	30.1%
Chemistry:	26.1%
Engineering:	22.1%
Materials Science:	10.2%
Space Science:	4.0%
Other:	3.5%
Computer Science:	2.2%
Mathematics:	1.3%
Astrophysics:	0.4%



Technology Development and Prototyping

Development geared toward increasing the readiness of available technologies for adoption by the space community.



Rapid and Agile Acquisitions

Accelerating traditional acquisition cycles by using science to identify and exploit efficiencies in mission assurance.



Resiliency and Space Warfighting R&D

Research and development advancements to enable space-domain asymmetric advantage and space resiliency.

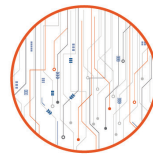

Advanced Concepts

Application of unique Aerospace competencies to fulfill future customer needs.

Examples of PSL Expertise and Technologies



Technology Development and Prototyping: Innovative Replicated Optics. A PSL team has been using replication technology and lightweight materials to create high-precision optics free from traditional mirror grinding or polishing requirements and much lighter in weight. Scientists in our materials lab use lightweight composites and Aerospace-patented protocols to produce these mirrors and have conducted rigorous experimental investigations of stress relief and stabilization of the optics with extreme humidity exposure tests. This realistic handling and exposure has dramatically improved the confidence in mirror performance, cutting both weight and production times, and fundamentally improving acquisition tradeoffs for next-generation space systems.



Technology Development and Prototyping: Replicated composite optics are fabricated to be lightweight, reducing manufacturing time and cost.



Rapid and Agile Acquisition: Accurate Space Photovoltaics Characterization for Advanced Technology Infusion. Solar cells and solar arrays are among the most vulnerable and costly subsystems for a spacecraft. As acquisition cycles shorten and threats become more dynamic, Aerospace is responding with agile mission assurance processes supported by state-of-the-art solar cell characterization and prototyping. Our space photovoltaics expertise has been critical to the development of the Aerospace Measurement Unit, which combines high-precision zero-drift analog circuitry with low power digital electronics to allow for laboratory-grade measurements of current, voltage, temperature, and solar illumination angle at a fraction of the size of a traditional test setup. Customers can characterize the on-orbit performance of advanced solar cell technologies in the lab, allowing for quicker infusion of advanced technologies into space systems.



Rapid and Agile Acquisition: Aerospace has developed a miniaturized test platform to measure the performance of solar cells above the ozone layer to calibrate the solar simulator in the lab.



Resiliency and Space Warfighting Research and Development: Space Domain Awareness Enabled by Sensors on the Ground and in Space. The Remote Sensing Department has decades of experience in both developing sensors and collecting data in all wavelengths of light, from visible to infrared. Our sensors are embedded in a wide range of platforms, ranging from some of the largest telescopes on the planet to the smallest cubesats on orbit. These systems serve as testbeds, calibration sources, and data collection sources to enhance our customers' insights into operational environments and to provide options for mission execution.



Resiliency and Space Warfighting R&D: Our Hyperspectral Imaging lab sensors are embedded in a wide variety of platforms.



Advanced Concepts: Quantum Photonics Technologies. Quantum technologies use the properties of atoms and photons to measure or produce phenomena fundamentally inaccessible with classical systems. Quantum properties can be exploited to perform secure communications, signal-to-noise enhanced sensing and imaging, parallelized computing, and other applications that can significantly impact the implementation and operation of space assets. The quantum cryptographic lab features several custom analytical and numeric toolsets for the analysis of quantum photonics-based systems. The team has built multiple testbeds for the evaluation of photon sources and detectors integral to the implementation of photonics technology.

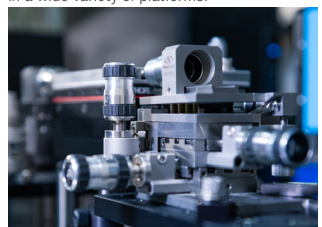

Advanced Concepts: Aerospace has built a fully functioning quantum cryptographic lab.

The Aerospace Corporation

The Aerospace Corporation is a national nonprofit corporation that operates a federally funded research and development center and has approximately 4,000 employees. With major locations in El Segundo, Calif., Albuquerque, N.M., Colorado Springs, Colo., and the Washington, D.C., region, Aerospace addresses complex problems across the space enterprise and other areas of national significance through agility, innovation, and objective technical leadership.

ACCELERATED MICROELECTRONICS FOR SPACE



Rapid and Agile Acquisitions



The Transmission Electron Microscope can perform atomic-resolution imaging of state-of-the-art semiconductor devices.

The most advanced microelectronics fabrication nodes being developed today have not been space qualified yet. Next-generation space systems have a need for rapid technology insertion to increase onboard data processing capability and provide size, weight and power savings. Aerospace is developing a team to accelerate proto-qualification activities on cutting-edge microelectronics components. We have the requisite expertise, lab capability, mission, and collaborations with other labs and universities. The team will address the challenge in four parts:

1. Modeling and Simulation

Current digital engineering approaches are largely focused on the system level. We intend to extend this downwards through the system to the component level. High-fidelity performance, reliability, and radiation effects simulations of advanced complementary metal-oxide-semiconductor nodes will advance digital engineering at the foundation of a space system: the semiconductor component.

2. Destructive Physical Analysis and Construction Analysis

In many instances the geometry and composition of a process node, which is key to the expected reliability and radiation performance of a part, is not known outright. A destructive physical analysis can readily identify a part's process node geometry and composition. Aerospace has an extensive suite of tools already available to perform these analyses at the smallest scales.

3. COTS Test Vehicle Development

Access to the most advanced technologies in production is only available through the purchase of commercial off the shelf (COTS) systems-on-chip (SOC). Through judicious programming, critical logic functions can be exercised in a radiation environment to assess on-orbit reliability and performance. With off-the-shelf SOCs as test vehicles, the data we collect can be extended to any chip fabricated using the same process.

4. Device Fabrication

Reliability and radiation effects test chips are needed to evaluate the performance of processes where foundry data is lacking. Data on the test chips will increase the confidence in the use of parts that have not undergone rigorous space qualification. Test chips will be designed through Aerospace/university collaboration and fabricated through the University of Southern California's MOSIS wafer integration service.

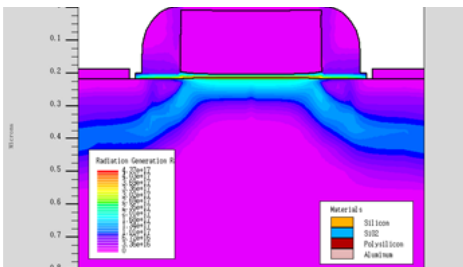

Radiation effects modeling in a metal-oxide semiconductor field-effect transistor.

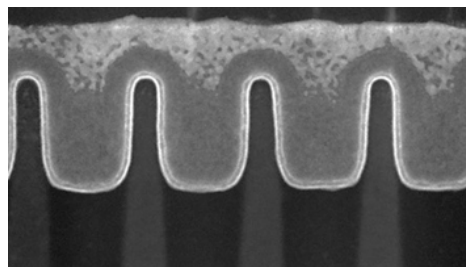

Aerospace's imaging and analysis tools are capable of studying the smallest components, such as this 16 nm fin field-effect transistor.

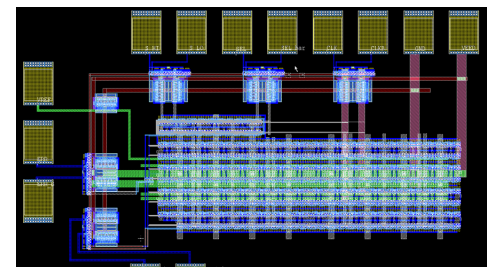

An Aerospace-designed pseudo-random noise generator to evaluate a Single Event Upset.

ADDITIVE MANUFACTURING



Technology
Development and
Prototyping

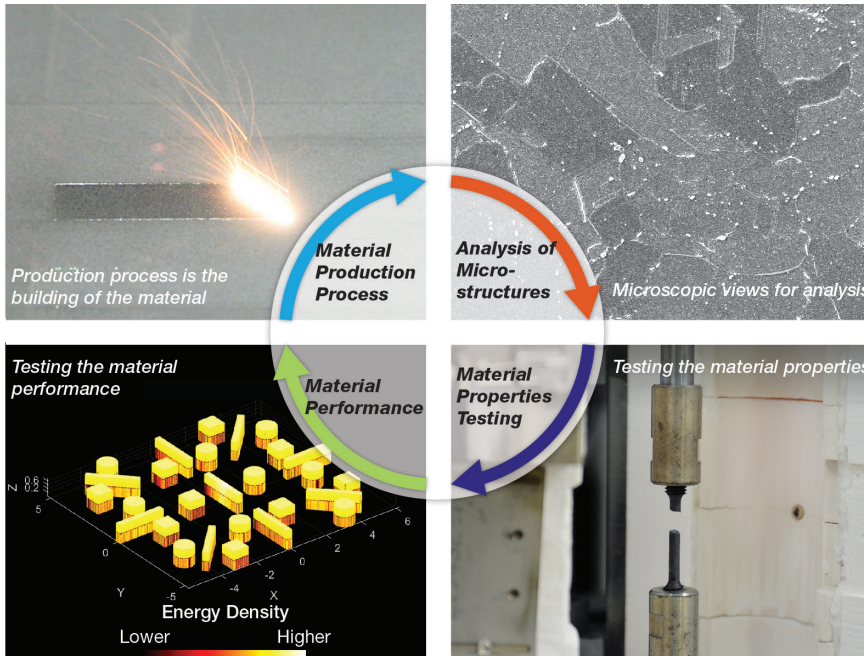

Unique Engineering Solutions in the Space Domain

Additive manufacturing (AM) is a revolutionary new capability in which materials can be printed into 3D forms layer-by-layer. Parts can be made with less cost, shorter lead times, and in novel geometries that are inefficient or impossible to create with conventional manufacturing. The versatility offered by AM technology has the potential to vastly improve our agility in the space domain.

Our in-house testing and characterization capabilities allow us to better understand the limitations of AM materials, determine what tests best predict their performance, and tailor unique microstructures that are currently not available with standard processing practices. Ultimately these tools can be used to manufacture prototypes and hardware to develop unique engineering solutions like composite replicated optics and antenna structures.

Materials science is about understanding the relationship between the processing, structure, properties, and performance of any given material. Studying how the metrics of a build relate to overall part performance results in updated processing parameters to optimize material properties.

Aerospace has been a leader in additive manufacturing since 2012, initially supporting the EELV launch development program office. In 2016, we began working with metal when we acquired our own in-house selective laser melting (SLM) capability. We collaborate with other Aerospace groups on AM manufacturing in areas such as structural analysis, machine learning, and propulsion. We have over 75 publications on the topic, patents, and have presented extensively throughout the community.



Aerospace Circle-A logo manufactured out of Invar.



Aerospace scientists prepare to quench metal samples during the heat treatment of Ni-based superalloys.



Additive manufacturing enables the production of geometrically complex parts as monolithic pieces, increasing manufacturing efficiency while reducing costs and lead times.

AEROTEL/REMOTE SENSING



Resiliency and Space
Warfighting R&D



Technology
Development and
Prototyping

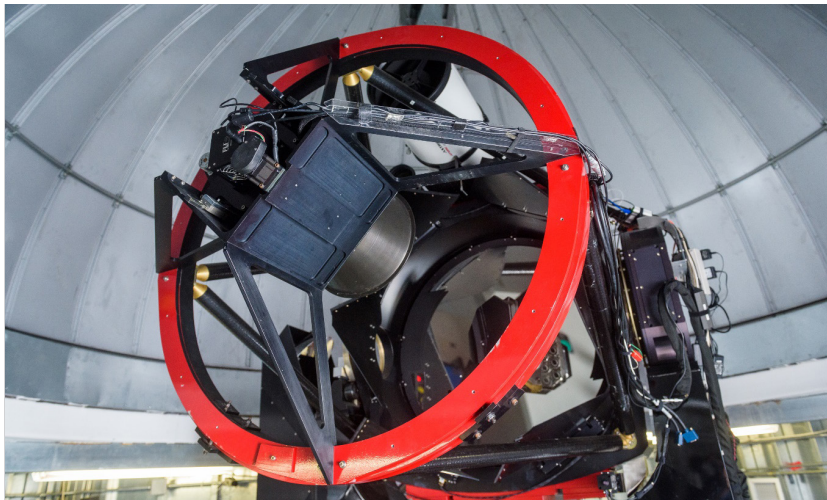

AeroTel is a 1-meter telescope that serves as a testbed for new sensors and as our own on-site observatory.

AeroTel is one of Aerospace's on-site telescopes, developed and operated by the Remote Sensing Department. It serves as both a testbed for new types of sensors that we develop here at Aerospace and as our own observatory. These novel sensors are developed both for Space Domain Awareness and scientific inquiry. As an observatory, we can obtain unique data of immediate interest for our customers, responding as soon as the need arises.

The Remote Sensing Department has decades of experience developing and collecting data with a large variety of different types of sensors. Rather than focusing solely on visible light imaging sensors, we have experience at all wavelengths from visible to long-wave

infrared light as well as phenomenologies such as polarimetry and spectroscopy. Aerospace's sensors operate on a suite of research telescopes ranging up in size to some of the largest telescopes on the planet, such as the Gemini North 8-m telescope on Maunakea, Hawaii.

Aerospace's Visible and Near-Infrared Imaging Spectrograph (VNIRIS) is heavily utilized for study of resident space objects (RSOs). Aerospace's visible-light POLarimeter for Inclination Studies of Hot Jupiters 2 (POLISH2) is used to study RSOs and a variety of astrophysical objects including extrasolar planets, solar system asteroids, and pulsars. Aerospace's Short-Wave Infrared Camera for AeroTel (SWIRCAT), which is the engineering model for a sensor currently aboard the International Space Station, enables wide field of view imaging of resident space objects from LEO to geostationary orbits. Finally, Aerospace's Broadband Array Spectrograph System (BASS) is regularly used to deliver ground-truth data to the Space-Based Infrared System (SBIRS) program for calibration of each space asset.

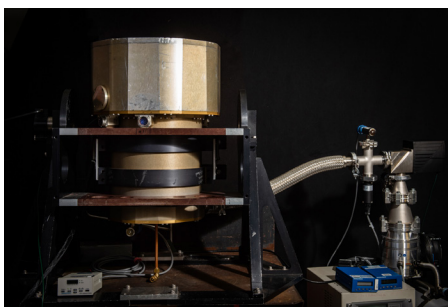

Aerospace's BASS instrument is regularly used to calibrate space assets.



AeroTel sits on the roof of Aerospace's El Segundo, CA, lab facilities.

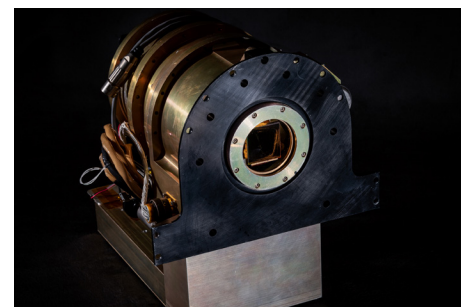

SWIRCAT is used for space domain awareness and for infrared imaging of celestial objects.

ATOMIC CLOCKS



Technology
Development and
Prototyping



Rapid and Agile
Acquisitions



Dr. Daniele Monahan investigates the microwave interrogation on a next-generation atomic clock testbed.

Atomic clocks and precise timekeeping algorithms are essential for robust, resilient, and effective position, navigation, and timing (PNT) and communications. High-performance atomic clocks are found in global navigation satellite systems (GNSS), such as GPS; MILSATCOM satellites, such as Advanced Extremely High Frequency (AEHF); and ground stations all over the world. The timekeeping algorithms in these constellations and ground systems are critical for optimizing timekeeping performance to meet mission requirements and objectives.

The Atomic Clocks and Precise Timekeeping Laboratory investigates the underlying physics of current and next-generation atomic clocks

and examines how the physics and mechanisms of these devices affect the algorithms used for precise timekeeping. Our lab tests actual flight clocks in a simulated space environment to evaluate their on-orbit performance under anomalous or stressing conditions. These next-generation clock testbeds investigate the physics and viability of new clock technology for improved timekeeping and reduced size, weight, and power.

The atomic clocks group has presented and published hundreds of atomic clock related studies and provided subject matter expertise for many Aerospace customers on clock and precise timekeeping programs. The next generation of atomic clocks will adopt new technologies such as lasers and photonic integrated circuits. We are prototyping these new technologies to better understand the physics and performance improvements and to accelerate the manufacturing on-ramp process.

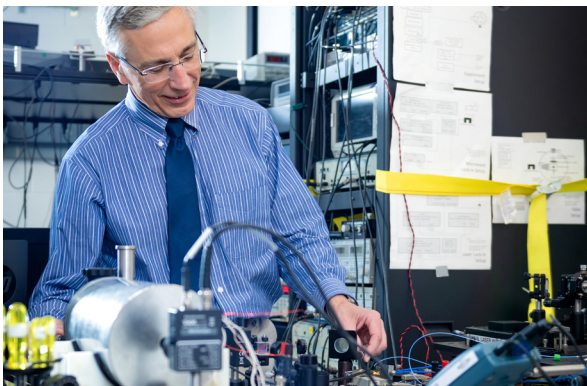

Aerospace Technical Fellow Dr. James Camparo examines the laser alignment on a next-generation atomic clock testbed.

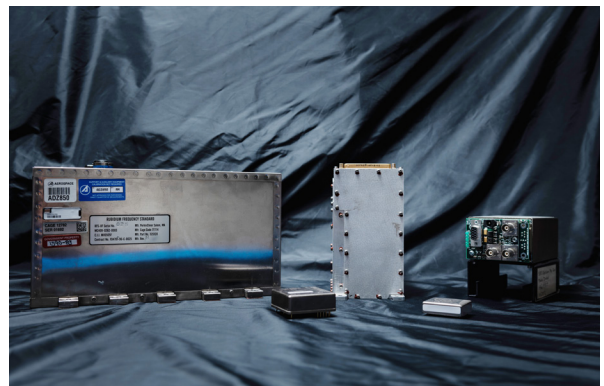

Evaluating atomic clocks of today: (clockwise starting with top left) GPS IIF RAFS, AEHF RMO, PRS10, CSAC, LN-CSAC.

COMPOSITES



Technology
Development and
Prototyping



Rapid and Agile
Acquisitions

Composite materials are common in a wide range of ground and air-based industries, but composites used in spacecraft have unique requirements and considerations. The Composites Laboratory not only has extensive knowledge and experience supporting composite space hardware, we also have the facilities to manufacture and study composite materials.

Aerospace has supported every aspect of composite materials for space applications from high-temperature carbon-carbon composite processing for exit cones and nozzles to low-moisture absorbing polycyanurate resin components for satellite structures. Our expertise coupled with our manufacturing capabilities allows us to support composite space hardware issues for a wide range of programs and customers.

The Composites Laboratory has extensive experience and the full suite of capabilities to manufacture parts, evaluate composite microstructures, and thermally and mechanically test composite materials. Our unique experience in the manufacture and development of non-structural composites for innovative space solutions means we stand apart from the rest of the space industry in this field.

Aerospace continues to stay on the forefront of composites research by characterizing new composite materials for reusable launch vehicles, carbon-loaded composites for antenna applications, and replicated optics that stand to revolutionize optical components for space. We are also pioneering new manufacturing and testing protocols and methodologies for a more agile industry.



In the Composites Lab, we pair our manufacturing and analytical capabilities to provide end-to-end expertise for our customers.

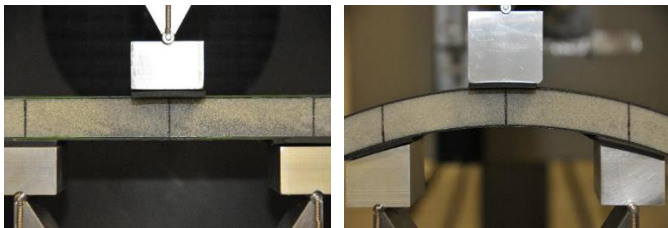

Composite materials destined for use in space have more rigorous requirements than those commonly used in other industries.



The Composites Lab features manufacturing capabilities that grant personnel firsthand experience in the manufacturing processes that impact Aerospace's customers.

DIRECTED ENERGY



Resiliency and Space Warfighting R&D

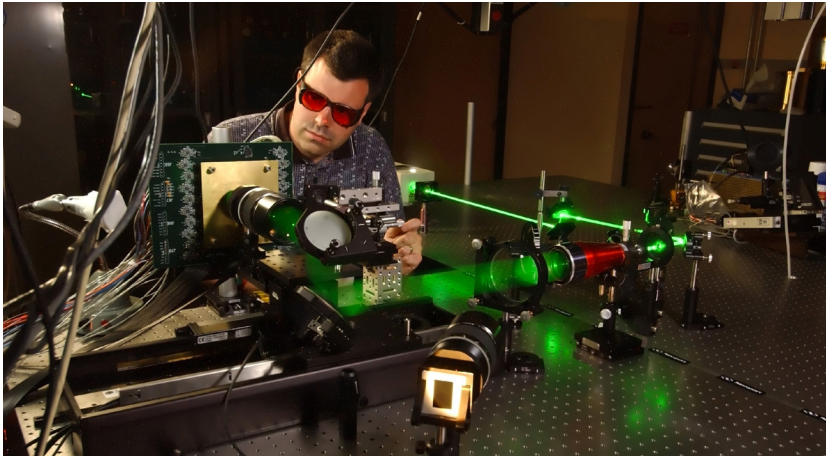

Our new dedicated laboratory facility will enable us to rapidly assess threats and the relationship between orbit, CONOPS, and the effect on mission capabilities.

As the space environment grows increasingly contested, the threats to critical space assets and associated ground systems will increase. High-energy laser and high-power microwave technology has become more prevalent and mature, elevating the threats associated with these types of potential attacks. These directed energy effects pose risks to space systems and their ability to perform critical mission functions by damaging, degrading, or denying system operation. In order to outpace these emerging threats, we need to understand the mechanisms through which the threats can exploit our systems and architectures. This understanding will lead to more resilient designs of spacecraft and ground systems, and ultimately a more resilient space architecture and enterprise.

Aerospace is leading the creation of an Integrated Product Team (IPT) and Center of Excellence designed to provide rapid program risk reduction via cross-departmental collaboration and agile, independent tests of defensive concepts. The capabilities we are bringing together and enhancing will produce device-to-system level requirements, verification and CONOPS options, in addition to independent verification of risk and resiliency. It is essential that we can support our customers by rapidly understanding and addressing emerging threats to protect national space superiority.

As directed energy systems proliferate, it is critical to acquire quantitative understanding of the mechanisms of their action on space systems and their components. The Aerospace team accomplishes this using a combination of modeling, simulation, and laboratory measurements. We have established expertise in the many fields that together address the threats presented by directed energy. This expertise ranges from high energy lasers, end-to-end system modeling, high power microwaves, sensor technology, and mission analysis. This IPT not only includes a new dedicated directed energy effects laboratory facility but also brings enterprise-wide expertise from across Aerospace, developing existing capabilities and experience to improve agility and effectiveness.

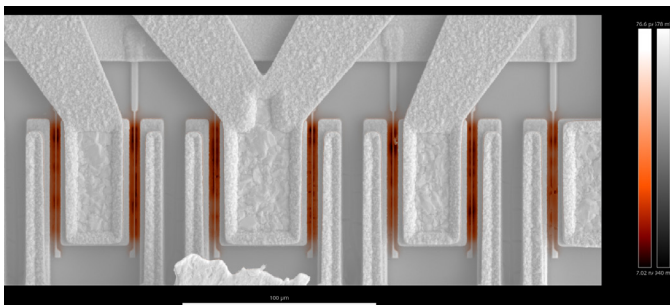

Aerospace has an advanced suite of physical analysis capabilities that can rapidly assess component damage. Above we see clearly defined high-power microwave damage regions detected by Electron Beam Induced Current imaging.

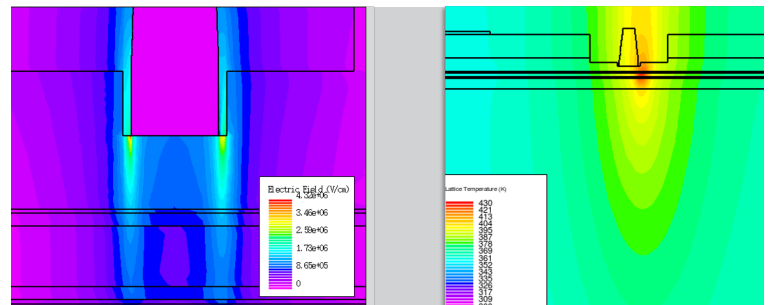

An all-encompassing modeling approach leads to a more comprehensive understanding of directed energy effects. Above, thermal and electric field modeling results of a Gallium Arsenide Low-Noise Amplifier under short pulse radio frequency exposure were used to understand device performance data and destructive physical analysis results.

ELECTRIC PROPULSION



Technology Development and Prototyping



Rapid and Agile Acquisitions

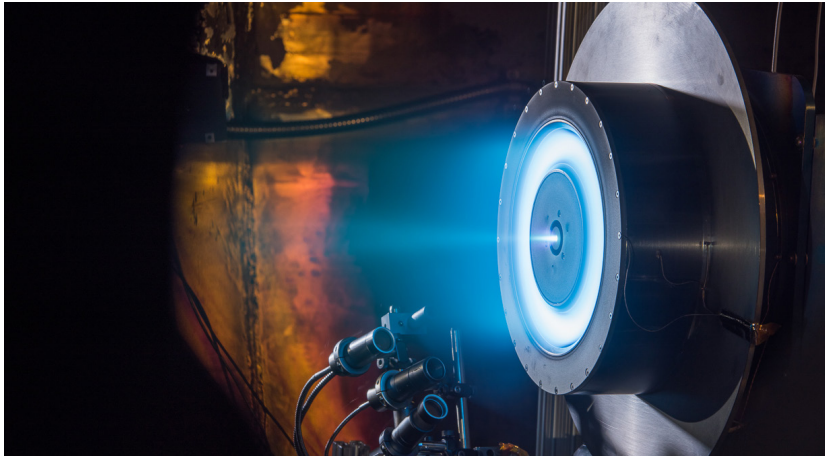

A prototype 13-kilowatt Hall thruster is tested at NASA's Glenn Research Center in Cleveland. Image courtesy of NASA.

The Future of Satellite Propulsion

Electric Propulsion (EP) devices rely on the generation of a plasma – the fourth state of matter – to generate thrust. The thrust of the typical EP device is about the equivalent of the weight of a quarter in your hand, but the high efficiency and long life of these thrusters make them perfect for satellite orbit insertion, repositioning, and deep space missions.

Technology limitations have traditionally constrained broad adoption of electric propulsion devices. The introduction of more efficient solar arrays and the maturation and diversification of EP technologies have inspired renewed interest. Several manufacturers are now producing fully electric satellite buses and

high-powered EP thrusters that will require testing in space-like conditions.

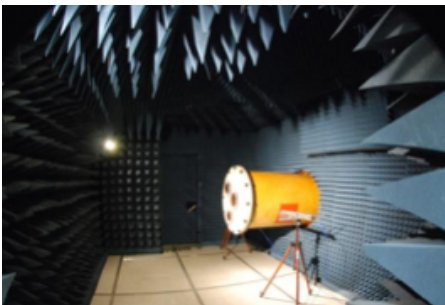

End-to-end testing

The Physical Science Laboratories provide end-to-end testing of electric propulsion thrusters, from measuring thrust, exhaust velocity and specific impulse to more advanced work like plume characterization, which helps quantify the risk of damage to other parts of the spacecraft. The lab also offers non-invasive testing using laser and optical diagnostics.



The future of EP testing

PSL is building a new EP vacuum chamber slated to go online by the end of 2020. The new facility will have the highest pumping speed of any EP testing facility in the world with unrivaled electromagnetic interference and electromagnetic capability testing. It will double our EP testing capacity and allow us to accommodate the newest EP technologies.



Features of the new ep vacuum chamber:

- 14' diameter x 30' long
- Pumping speed on Xenon > 750,000 L/s
- Custom-made pumping system
- 6" diameter fiberglass cone appendix for EMI measurements

ENVIRONMENTAL TESTING



Technology Development and Prototyping



Rapid and Agile Acquisitions

Between manufacture and launch, space components often spend long periods of time being handled or in storage. Environmental testing is essential to determining the quality and durability of critical flight components. The Environmental Testing Laboratory offers acquisition support in assessing the durability of a wide range of components including optics, optical coatings, and electronics.

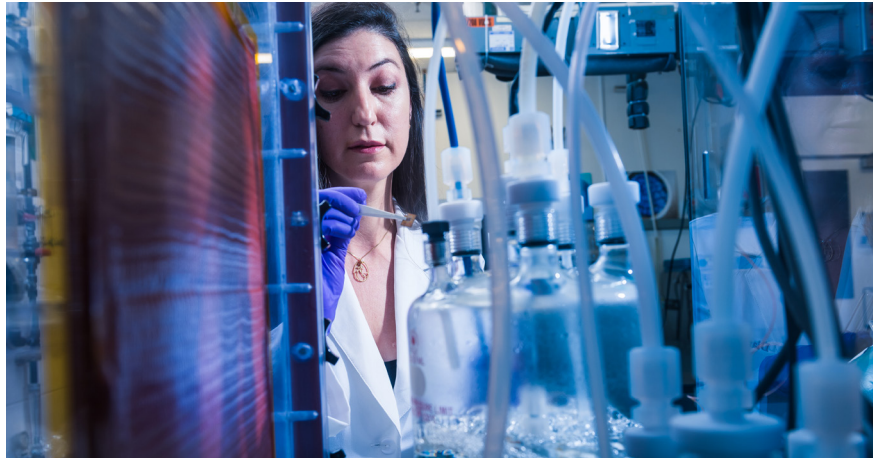

Aerospace is the first to use the mixed-flowing-gas test method to assess metallic mirror coatings, which are a critical component in many space systems.

The Environmental Testing Laboratory is equipped with a humidity chamber, a salt fog chamber, and a mixed-flowing-gas (MFG) testing system. The humidity and salt fog tests are conventional durability tests for optical coatings as specified in many military standards. The MFG is an accelerated test that simulates the kinetics and degradation mechanisms of metals found in indoor environments.

Aerospace is the first to utilize the MFG test method to assess metallic mirror coatings, which are a critical component in many space systems. The MFG test utilizes synergistic effects of temperature, humidity, and low concentrations of three air pollutants to achieve accelerated atmospheric corrosion of metals.

We plan to further develop the MFG test as an accelerated life testing method for metallic mirror coatings. Additionally, with the combination of a long-exposure study and MFG testing of silver mirror coatings, we now have some preliminary data for predicting the life of one type of silver mirror. Expanding the study to include additional mirror types will allow us to build a database on the life expectancy of this critical component.

We continue to develop our capabilities and upgrade our test equipment to improve the control of test conditions and afford more efficient and accurate testing performance for our customers.



A salt fog test performed on a mirror resulted in distinct blue, cloud-like shapes, which are chemical corruptions on the mirror surface caused by the salt.

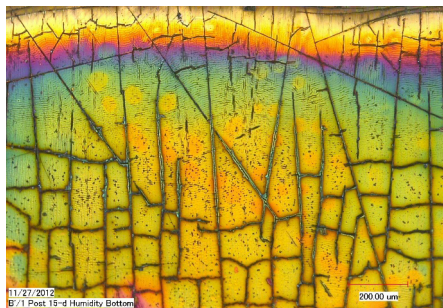

A closeup of the corrosion and cracks on the edge of a conductive coating sample after a humidity test was performed.

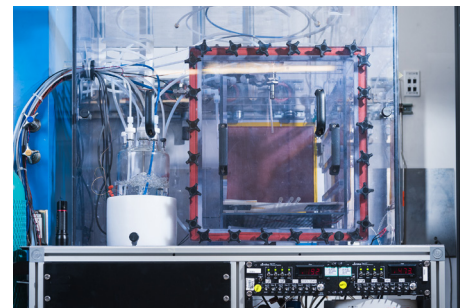

The mixed-flowing-gas testing system simulates the kinetics and degradation mechanisms of metals found in indoor environments.

FIBER LASER DEVELOPMENT LAB



Technology
Development and
Prototyping

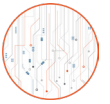

Advanced
Concepts

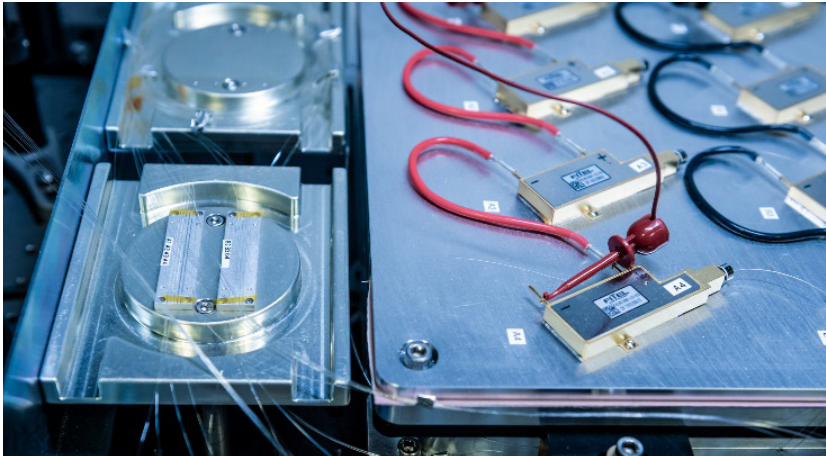

A fiber amplifier, which combines power from multiple smaller lasers.

Fiber lasers have revolutionized laser applications in manufacturing, medicine, communications, and space. They are compact and flexible compared to traditional lasers, which makes them mission enabling for many applications. Aerospace is researching fiber lasers and evaluating the related industrial supply chain for space relevant missions. In addition, Aerospace maintains deep expertise in many areas enabled by fiber lasers so that we can advise our customers and provide guidance toward future mission assurance.

The Photonics Technology Department has over 20 years of experience in advanced laser solutions relevant for our customers' missions. Aerospace focuses fiber laser research in areas that are not addressed by industry but are required for our customers:

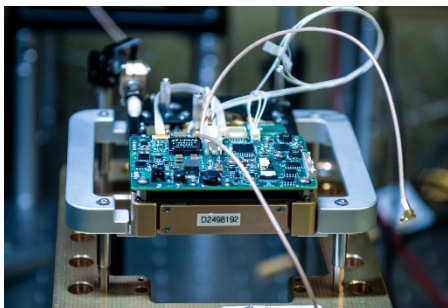

In communications, fiber lasers are used to send messages via on/off pulses of light. We are demonstrating fast communications (broadband) from small CubeSats that can provide data-rich content from a low size, weight, and power (SWaP) platform.



Lidar is essentially a light-based radar that can make use of the pure output of fiber lasers. Larger systems can amplify output performance while maintaining purity of the starting laser, enabling detection of minuscule objects over very long distances. The MAFIOT telescope at our Mt. Wilson facility is a long-range lidar system utilizing a fiber laser that was developed in-house.

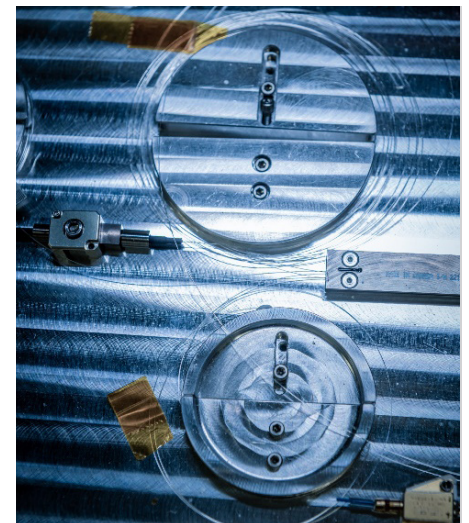

We perform satellite sensor calibration by directing fiber lasers with known power and wavelength into space.

FREE-SPACE LASER APPLICATIONS



Resiliency and Space Warfighting R&D



Technology Development and Prototyping

The Sky Access Lab uses cutting-edge technology developed at Aerospace to give us a better look at the sky. Laser technology has evolved dramatically over the past 50 years, and the ways lasers can be applied to space programs have advanced commensurately. At Aerospace, we investigate ways in which emerging laser and detector technologies can support the needs of national security space.



The MAFIOT telescope serves as a testbed for emerging laser technology.

Light detection and ranging (lidar) is a remote sensing method used to measure distances by illuminating the target with a laser and measuring the reflection. By developing fiber lasers in the lab that are small but have “pure” output — meaning the power, beam quality, and wavelength (color) are all as nearly perfect as possible — larger systems can amplify output performance while maintaining the purity of the starting laser. This enables lidar to detect very small objects over very long distances in space.

The Mt. Wilson Aerospace Facility for Integrated Optical Tests, or MAFIOT, provides a unique testbed to support a wide range of optical experiments, including atmospheric laser propagation, atmospheric scattering, laser communications, and other laser applications. MAFIOT is designed to augment space domain awareness capabilities that combine different wavelength bands of light for passive and active tracking, better characterizing space objects.

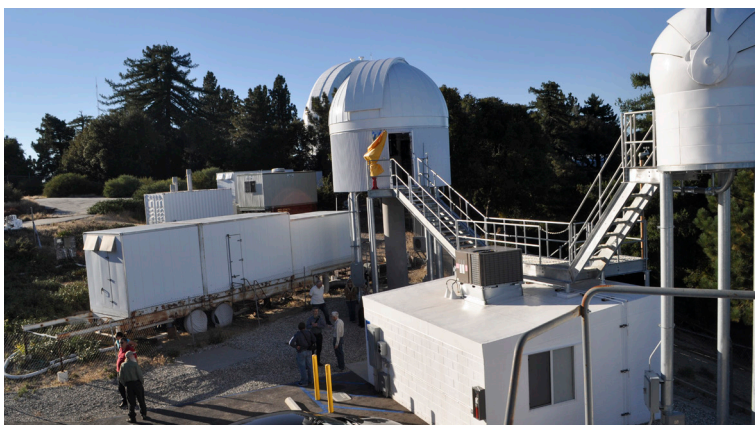

The Mt. Wilson Aerospace Facility for Integrated Optical Tests (MAFIOT).

A HERITAGE OF LASER CAPABILITIES TO MEET CRITICAL CUSTOMER NEEDS:

- Development of the laser beacon program to support all OPIR assets
- Development of the Aerospace Transportable Lidar System to provide ground truth to the Defense Meteorological Satellite Program
- Development of the Mt. Wilson Aerospace Facility for Integrated Optical Tests (MAFIOT)

HYPERSPECTRAL IMAGING



Resiliency and Space
Warfighting R&D

Airborne infrared hyperspectral imaging (HSI) can detect gases and solids on the ground from a safe distance, with applications ranging from earth science to domestic counter-terrorism. While the Department of Defense routinely uses this capability to spot ground-based vehicles, Aerospace has expanded it into Earth science applications, such as mineral mapping, global warming studies, and crop health analysis.



The hyperspectral imaging team at Aerospace focuses on end-to-end mission support, from planning to data analytics. Our aim is to be responsive, and we are constantly working on new approaches to support the time-critical missions of our customers.

The Aerospace-developed MAHI and Mako sensors provide the best combination of sensitivity and aerial coverage available to our diverse customer base. Combining that with our unique science expertise, the Aerospace team can perform missions that no one else can.

As the world's climate heats up, many areas in the western United States are experiencing increasingly larger and more devastating wildfires, along with a corresponding increase in dangerous air quality from wildfire smoke. An Aerospace team took to the skies to capture valuable data related to the environmental and atmospheric effects of these wildfires and the smoke they generate.

The FIRESTORM 2020 mission flew a Twin Otter aircraft at altitudes of 12,500–17,500 ft above the Creek Fire burning east of Fresno, Calif., now recognized as the largest fire in the state's history. Mako and MAHI were onboard the craft, detecting and identifying gases resulting from widespread wildfires, and analyzing the movement and effects of these gases on the environment.

The need for these sensors and Aerospace's expertise will only grow with the challenges faced by our intelligence, law enforcement, and climate communities. The HSI team's continued work will focus on faster response time for agile customer support, mission-tuned hardware and software prototypes, and customer-specific informatics that tailor our response to the unique needs of every mission.

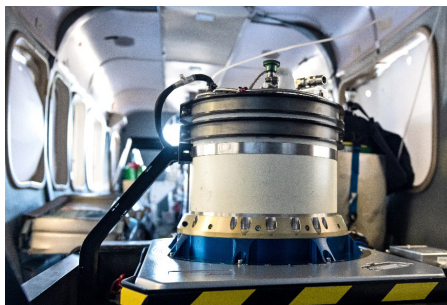

Mako is a longwave infrared scanner capable of 128 bands of spectral resolution. Pictured here aboard a Twin Otter aircraft prior to the FIRESTORM mission.



MAHI (left) is a midwave infrared scanner capable of 640 bands of spectral resolution. During the Creek Fire of 2020, it was used to measure toxic gases during a series of flyovers.

LASER BEACON



Resiliency and Space
Warfighting R&D



Technology
Development and
Prototyping

Laser beacon systems are used during calibration/validation tests of new sensors. Beacon systems allow government customers use of an independent, low-cost resource that can be deployed on short notice — a capability unique to Aerospace. The laser beacon project generates a suite of wavelengths ranging from the edge of the visible spectrum out to the mid-infrared and is used as a ground-based source for calibrating focal plane arrays on existing satellite assets.



The remote operated "Robo-Beacon."

Aerospace is in the process of upgrading laser sources to give broader coverage of the types of sensors that the beacons can simulate during the execution of a calibration/validation test. The uniqueness of the Aerospace beacon systems is their variety. Fully equipped mobile beacons, small footprint "Mini-Beacons" or a remote operated "Robo-Beacon" can be used depending on the level of support required.

Since 1971, an Aerospace beacon system has been involved in every early-orbit test of a Defense Satellite Program or Space-Based Infrared System satellite. Aerospace also has experience in deploying beacons outside of the continental U.S.A. with the first such deployment to Maui, Hawaii, in the late 1980s. The beacon laser is currently being upgraded to support higher power operation and additional wavelengths.

As beacon capabilities advance, Aerospace continues to expand requirements to meet customer needs. These new challenges have spurred the evolution of new laser sources and operational techniques. Future beacon developments will increase the remote operability of systems, and these systems' replication will reduce overall operating costs and personnel needs while improving beacon functionality.

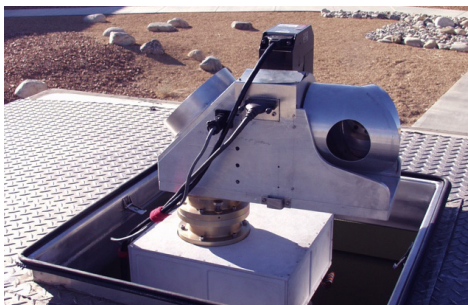

The gimbal atop the first mobile beacon.



The first laser beacon, circa 1970s.



The mobile beacon in Australia.

MICROELECTRONICS

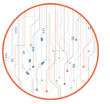

Advanced Concepts

Spacecraft contain tens of thousands of microelectronic parts that need to work reliably in the harsh environment of space. As the aerospace industry shifts to greater use of consumer electronics and faster development and delivery cycles, the need arises for faster, more agile microelectronic reliability assessments and screening methods.

Aerospace has tools and the techniques necessary to assist our government and contractor customers to develop mission-relevant screening methods, and to provide critical and timely microelectronics parts assessments when problems arise.

The Microelectronics Lab has a state-of-the-art suite of tools for analyzing structure and defects in modern microelectronic devices down to the atomic scale. Understanding device features and trace level contamination is essential for addressing degradation and reliability concerns in microelectronic devices. We investigate the entire life cycle of a component, including design, fabrication, how the component reacts to stress such as space radiation or extreme temperatures, and finally, we do failure analysis after the fact.

Aerospace is able to investigate problems deeply and provide information that is unattainable by the vast majority of contractors. We are constantly striving to improve our analysis capabilities and develop techniques in anticipation of problems in future materials, devices, and technologies. We provide solutions when programs and customers have no other options.

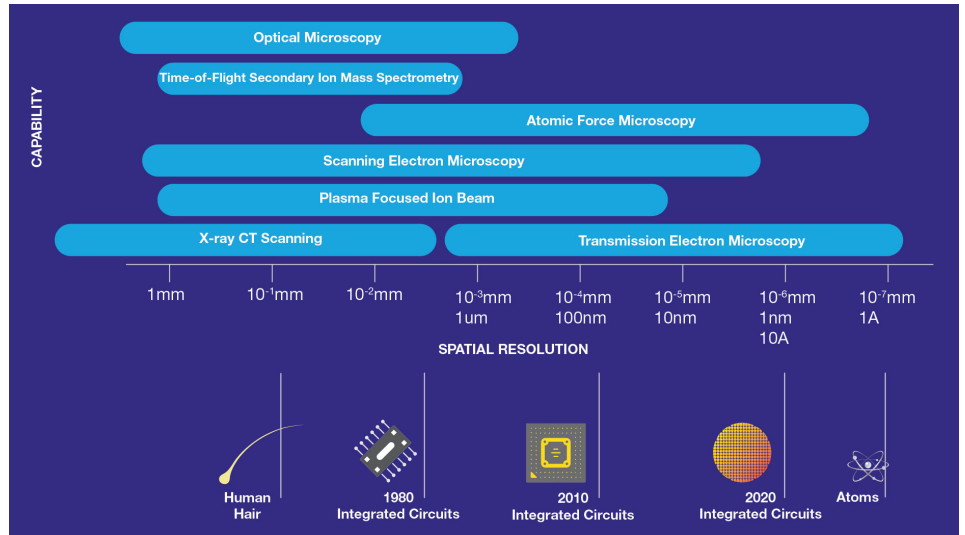

Our scientists use X-ray CT scanners to peer deep inside space systems and their components in search of flaws.



The plasma focused ion beam is a unique capability that can image, cut, manipulate, weld, and analyze microelectronic devices all in one.



The transmission electron microscope transmits a beam of electrons through a sample to create an image at incredibly high resolution.

MICROPROPULSION



Technology
Development and
Prototyping



Rapid and Agile
Acquisitions

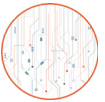

Advanced
Concepts

Testing Miniature Components

Aerospace has been involved with small satellites for nearly 20 years. Scaling down propulsion devices from large satellites to small satellites has been challenging and largely impractical due to power requirements and technology miniaturization. However, this is changing in today’s space environment, motivated by our customer’s need for agile, resilient space.

Our micropropulsion ground testing facility, nicknamed “The Snake Pit,” is outfitted with thrust stands and diagnostics specially tailored for testing miniature propulsion systems. This ground test data is essential for risk-reduction via qualification testing and predicting on-orbit performance. The chamber uses precise, delicate instruments, designed and built in-house, to measure how much thrust (force) a miniature thruster can produce.

The field of small satellite propulsion is growing fast, fueled by the influence of rapidly emerging startup companies. These startups often lack the test and diagnostic capabilities and expertise that our lab can provide. The knowledge generated from these test campaigns would benefit our customers, helping them select the correct systems for their missions. Our role as an FFRDC and our subject matter expertise in both small satellites and propulsion uniquely positions us to track, evaluate, and test these micro-propulsion systems for the benefit of our customers.



Senior Scientist Andrea Hsu examines an optical component for the torsional thrust stand, which is used to measure very small amounts of force in a vacuum environment.

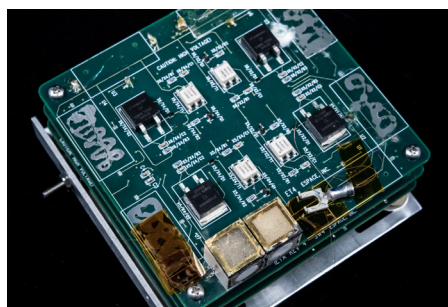

MIT’s Space Propulsion Laboratory, headed by Dr. Paulo Lozano, has provided us with electro-spray laboratory thrusters for testing. The thrusters are the small beige cubes, and they are mounted on computer boards that regulate the power supply. Aerospace tests both commercial and academic thrusters.



The torsional thrust stand allows scientists to measure very small forces, equivalent to the weight of an eyelash, that are produced by small satellite propulsion systems. The thrust stand must be carefully balanced and leveled before each measurement.

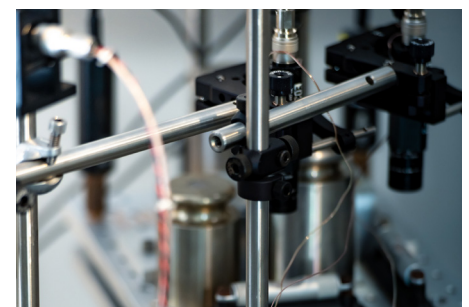

This sensitive instrument sits inside a large vacuum chamber to simulate conditions in space. Vacuum-compatible cameras allow scientists to monitor the health of the thrust stand while it’s under vacuum and running a test.

PHYSICAL SCIENCES LABORATORIES

NON-DESTRUCTIVE EVALUATION



Rapid and Agile Acquisitions

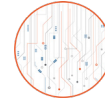

Advanced Concepts



Technology Development and Prototyping

The Non-Destructive Evaluation (NDE) Laboratory develops and practices techniques for screening parts and materials for flaws to ensure flightworthiness. The lab is equipped with a wide variety of capabilities and staffed with experts who have the experience and responsiveness to solve difficult and urgent problems that require unique and innovative solutions.

We actively pursue emerging technologies that can advance the current state of the art. One of the biggest needs is the development of field-deployable methods which enable NDE techniques and expertise to be promptly brought to the site of the problem.

The lab possesses all major NDE capabilities so that customers with last-minute requests and challenging inspection problems can benefit from Aerospace's ready-to-deploy inspection techniques. The breadth of capabilities at our disposal is unique and allows for a tailored approach for each inspection.

Among many responsibilities, the NDE group frequently inspects parts for the following criteria:

- Material defects in metallic and composite parts, such as cracks, delaminations, disbonds, porosity and others.
- Structural defects such as misplaces or missing inner components and wiring and connection problems.
- Materials characterization, such as degradation of rubber, preload stresses, microstructure, dielectric property measurement and others.

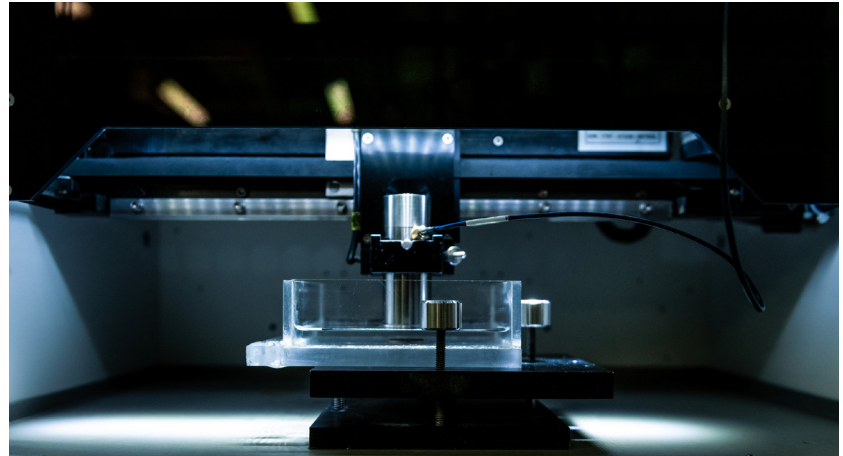

Acoustic microscopy can image the inner and outer parts of a component with sub-micrometer resolution.



Shearography is used to inspect a composite overwrapped pressure vessel, revealing weak spots due to damage.



A scientist operating the scanning acoustic microscope.

KEY CAPABILITIES:

- Visual-microscopy, SEM, borescope, dye penetrant
- Acoustic emission monitoring
- Radiography-portable sources (flash and microfocus), nano-focus, real time
- Thermography
- Ultrasound (contact, phased array, acoustic microscopy, EMAT, air-coupled, laser ultrasound)
- Shearography
- Eddy current
- Microwave and millimeter wave

OPTICAL COMMUNICATIONS



Technology
Development and
Prototyping



Rapid and Agile
Acquisitions

Communication is one of the most critical functions space assets must perform. The method that has been used for years is radio waves, but it imposes restrictions on newer missions involving smaller space assets and deep space (long-range) missions. Optical communications (which use lasers) offer many advantages compared with radio waves, such as smaller size, weight, and reduced power requirements, in addition to increased performance.

Optical communications can be broken down into two basic requirements: a source and a receiver. Our optical communications labs are working on

validating next-generation laser sources and detectors, namely lasers that are higher power while maintaining a low size, weight, and power footprint, and detectors that are very sensitive to very weak signals. We are demonstrating that powerful, compact lasers can be developed for space missions where laser comm is important. We are exploring the industry and evaluating highly sensitive detectors for use in space and applicability for communications.

There is a strong history of experience in optical communications within Aerospace, spanning more than 20 years. In 2018, we demonstrated the first space-to-ground optical comm link from a CubeSat, as part of the Optical Communications and Sensor Demonstration (OCSD) mission, which was funded by NASA. The laser signal was received at our Optical Comm Dome in El Segundo, California.

There is a constant need for faster, lighter, and better satellite communications systems. As the technologies for this field have evolved, so have the requirements. As communications technologies have matured in the commercial sector, Aerospace has kept pace with validating and demonstrating appropriate advancements relevant for space so that our customers can make the most informed decisions possible.



The Optical Comm Dome serves as a ground station to communicate with our laser comm-enabled CubeSats.

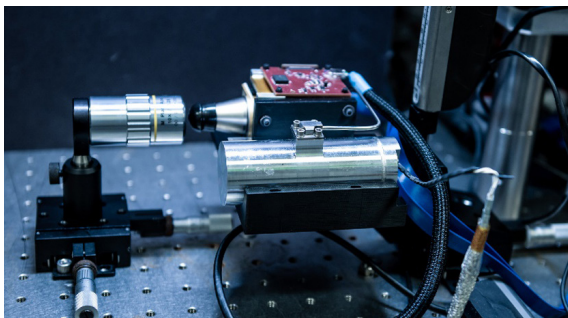

An array detector capable of counting individual photons, which reduces the power required for the laser transmitter.

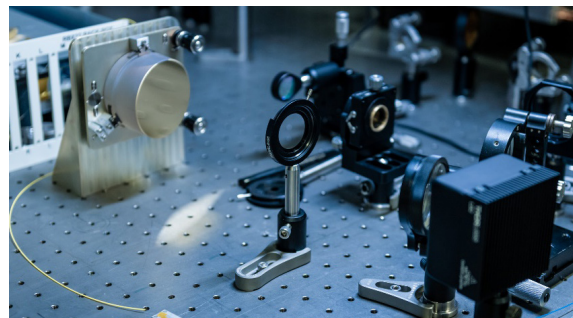

Optics used for converting the laser beam to the correct size and shape for transmission.

OPTICAL SIGNAL PROCESSING



Technology
Development and
Prototyping

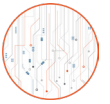

Advanced
Concepts



A photonic integrated circuit designed and built by Aerospace.

The new generation of modern space-based sensors generate ever-increasing amounts of data. Optical signal processing is a method to address these large data sets. Optical signal processing uses photons for computation in place of electrons. The attraction of optical signal processing is the ability to perform massively parallel calculations without electrical loss or heat generation. The enabler for optical signal processors is the advent of foundries that can produce photonic integrated circuits (PIC) that dramatically reduce the size of optical processors. At the same time, these foundries can inexpensively replicate PICs through standard integrated circuit fabrication processes.

Aerospace is using optical propagation in a special purpose PIC to perform the signal compression needed for a novel radio frequency receiver based on the compressive sensing technology. The goal of this work is to produce a packaged receiver that can detect arbitrary sparse signals across RF bands of interest with size, weight, and power (SWaP) requirements consistent with use on a CubeSat or unmanned aerial vehicle. This laboratory is supported by analytical simulations and PIC design software. Aerospace leads the world in compressive sensing for RF signals.

We are performing proof-of-principle experiments on photonic neural network architectures. These neural networks are expected to be low SWaP, high-speed solutions to problems such as classifying unknown signals, predicting unknown signals, and removing distortions such as multipath and nonlinearities from signals of interest. Two U.S. patents and journal articles contribute to Aerospace's lead in developing these technologies. We are now upgrading several aspects of the laboratory to allow processing of larger datasets at faster speeds.

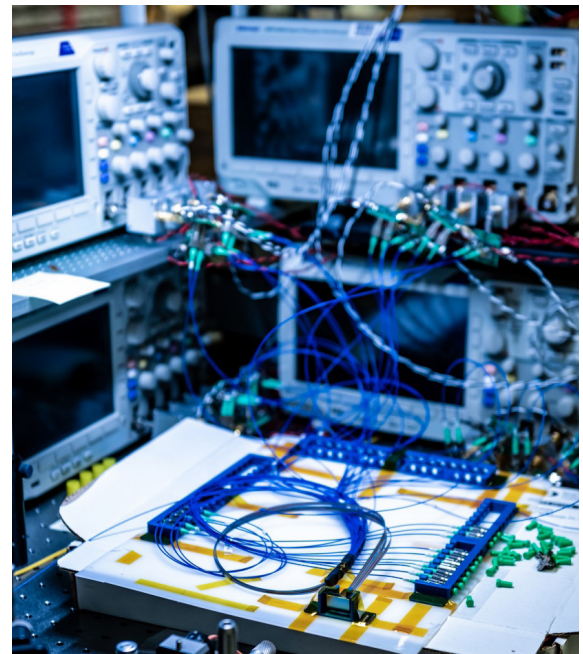

The optical signal processing work being performed at Aerospace stands to reduce the size, weight, and power of future satellite signal processing systems.

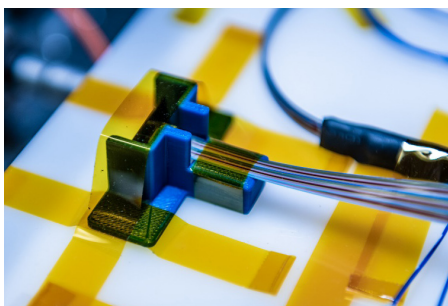

Optical signal processing uses photons to handle the enormous amounts of data that the communications systems of the future will require.

PROPULSION RESEARCH FACILITY



Technology
Development and
Prototyping



Rapid and Agile
Acquisitions



The Propulsion Research Facility at Aerospace

Propulsion is the requisite technology for enabling space access. Space systems are often exposed to extreme environments with narrow margins for structural integrity and to propellants that are extremely reactive. Testing these systems in a simulated environment is crucial to success.

The Propulsion Research Facility (PRF) performs tests that only a few other sites in the U.S. can perform. Our state-of-the-art diagnostics allow deeper understanding of the interaction of both chemistry and physics. Combined with Aerospace expertise, these capabilities enable our customers to improve propulsion reliability and performance.

Three Key Experiments

The Propulsion Research Facility is dedicated to investigating new technologies and propulsion systems.

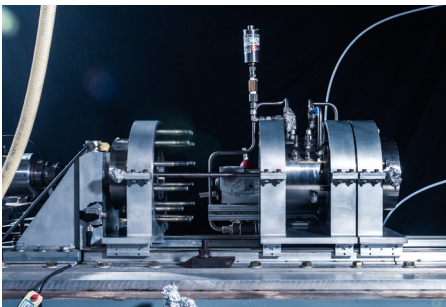

OXFIRE

Ignition of metals via friction within a high-oxygen environment can cause a catastrophic failure event. This experiment studies the ignition characteristics of various metals, rubbed together at high speeds within a high-pressure oxygen environment.

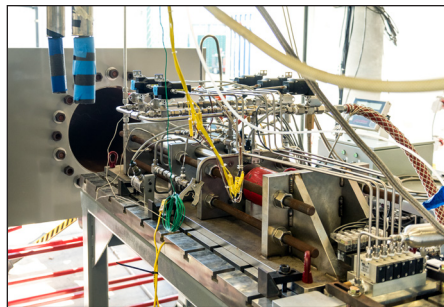

PUERIE

The two burner experiments in the PRF are the “Atmospheric Co-axial Injector Experiment” and the “Pressurized Uni-Element Rocket Injector Experiment” (PUERIE). These study combustion instabilities in liquid rocket engines and how they are coupled to feedline or chamber acoustic instabilities.

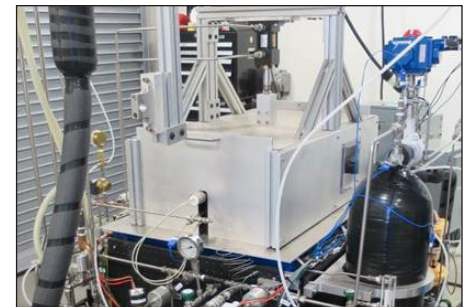

COKER

Liquid Natural Gas (LNG), an emerging propellant, contains some contaminants that may “coke” or deposit, inside of the lines, restricting or, in worst case scenarios, blocking them. This experiment characterizes coking tendencies for LNG under various environmental conditions.

QUANTUM PHOTONICS



Technology
Development and
Prototyping

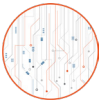

Advanced
Concepts

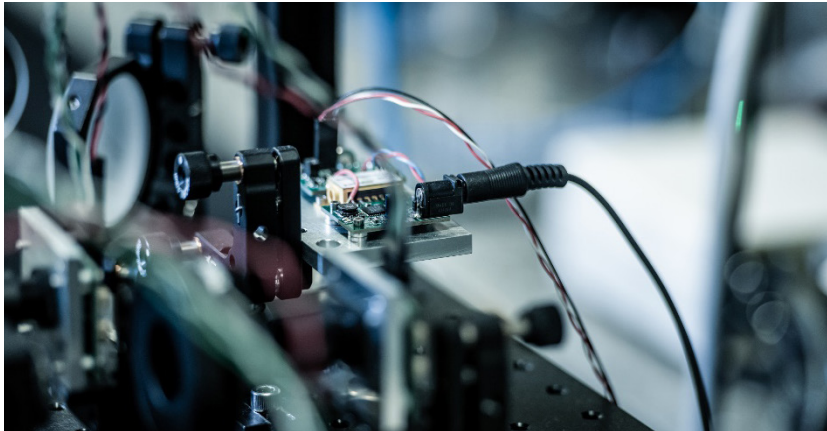

Quantum technology stands to revolutionize many of the communication, sensing, and computing processes we perform in space.

Evaluating entangled photon sources and detectors that are an integral part of quantum photonics technology.

We have a long history of technology development and maturation related to nonlinear optics, lasers, lidar, remote sensing, atomic clocks, optical communication, and optoelectronic devices for space applications. Such photonic devices make up the core subsystems of quantum photonics technology.

Aerospace has the deep technical expertise required to understand fundamental science, technologies, and their application substantiated by decades-long activities in photonics technology development for space applications. This makes Aerospace an objective agent to evaluate proposed solutions, provide informed guidance in the area without biases, and help guide contractors through technology development pitfalls.

Quantum technologies propose to use properties of atoms and photons to generate disruptive new technologies that are fundamentally inaccessible with classical systems. Such quantum properties can be exploited to perform secure communication, enhanced sensing and imaging, parallelized computing, etc. which will have significant impact on national security space and related programs.

Aerospace has demonstrated quantum applications in cryptography, developed analytical and numerical toolboxes to analyze system level implementations of quantum photonics technology, and built testbeds for



Aerospace has a long history of photonics expertise and leadership, which is critical to understanding the next generation of photonic devices.

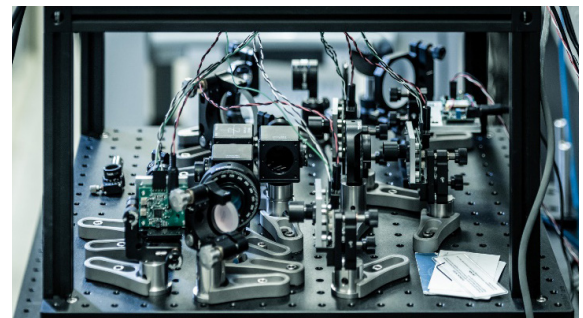

The Quantum Cryptographic Lab studies how to transmit data in a manner that is fundamentally secure.

RADIATION EFFECTS



Rapid and Agile
Acquisitions

Testing Miniature Components

There is significantly more high-energy radiation present in space than on the surface of the Earth. This high-energy radiation, also called ionizing radiation, can damage and degrade components like solar cell coverglasses, microelectronics devices, and composite materials. Testing components and materials for their susceptibility to ionizing radiation damage is essential to ensuring a full mission life for our space assets.

Aerospace has an extensive history testing ionizing radiation effects in materials and devices using Co-60 radiation, a simple and relatively inexpensive way to emulate the space environment. Aerospace has helped understand radiation effects in relevant materials and devices for over 30 years. Aerospace currently operates a 7000 Ci Co-60 irradiator, and also a low dose-rate irradiator dedicated to studying the ELDRS (Enhanced Low-Dose Rate Sensitivity) effect in bipolar microelectronic devices. These irradiators allow us to replicate the space environment and rapidly assess risk to critical satellite components.

The demand for evaluation of the effect of radiation on space components is only increasing. With the new need for rapid system acquisition and the lowering of cost for access to space, there has been an increased interest in fielding systems making use of commercial off-the-shelf (COTS) components. COTS parts radiation tolerance is generally lower than traditional space hardware, and also highly variable. This will necessitate new testing paradigms for higher throughput testing. Aerospace stands ready to pioneer these new testing approaches for a rapidly evolving space enterprise.



Aerospace's 7000 Ci Co-60 irradiator tests samples to determine how they would respond to the space environment.



The mug on the right was placed inside the Co-60 irradiator, and demonstrates the effects of radiation on glass.



Some devices actually have more trouble with a low dose of radiation, and this low dose-rate Co-60 irradiator is specifically for testing those types of devices.

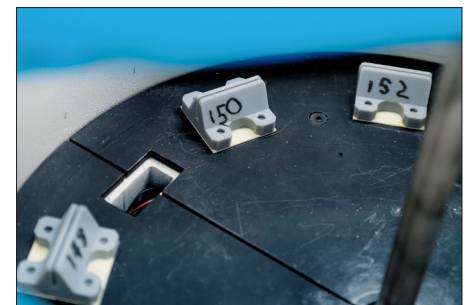

Samples inside one of the irradiators.

REPLICATED OPTICS



Technology
Development and
Prototyping

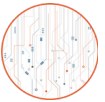

Advanced
Concepts



The composites used as a substrate for the optics are made in an autoclave, which controls the temperature, pressure, and cure time for composite fabrication.

Innovation Developed in the Lab

Replicated composite optics stand to replace conventional polished glass optics in precision imaging applications. Glass optics are heavy, require extensive manufacturing time, and are often the limiting factor for cost and schedule in space imagery satellites. Replicated optics, made from a polymer composite, can do the same job in much less time at a fraction of the weight. Aerospace developed this mission-enabling technology using our breadth of multi-disciplinary expertise.

Replicated composite technology allows for the use of freeform optics in imagery

systems that can't be achieved with conventional polished glass optics. Traditional glass mirrors require grinding and polishing to the required shape and smoothness and must be of extremely high quality to maintain their shape. Freeform optics are non-symmetric optical surfaces that allow advantages such as system miniaturization, fewer optical components, and even new functionality.

While replication technology has been used for decades, it had never been demonstrated to perform at the optical quality required for precision imaging applications. The innovative processes developed in the lab have resulted in lighter, cheaper mirrors that can be produced in a fraction of the time. The replicated optics team has also developed new test processes to ensure reliability of the mirrors in the harsh space environment.

Aerospace currently owns four patents on the curing and treatment processes developed to achieve the quality and stability necessary for space applications. The lessons learned from this multidisciplinary effort can be applied to other applications such as bonding optical components in payloads.

ADVANTAGES OF REPLICATED OPTICS OVER TRADITIONAL PROCESSES:

- Reduced weight
- Rapid manufacturability
- Low cost
- High impact tolerance
- Tailorable CTE and thermal conductivity

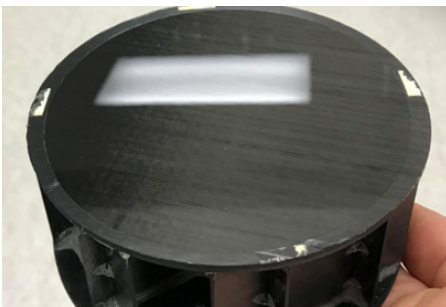

Replicated resin layer on a composite substrate with a composite core (after edge trimming and before metallization).



Comparison of a curved and a flat mirror: the object being imaged, at bottom, is a 3-D printed Inconel® Aerospace logo. The reflected image in the curved mirror at left appears magnified compared to the flat mirror on the right.

RF BREAKDOWN (MULTIPACTOR)



Resiliency and Space
Warfighting R&D



Rapid and Agile
Acquisitions

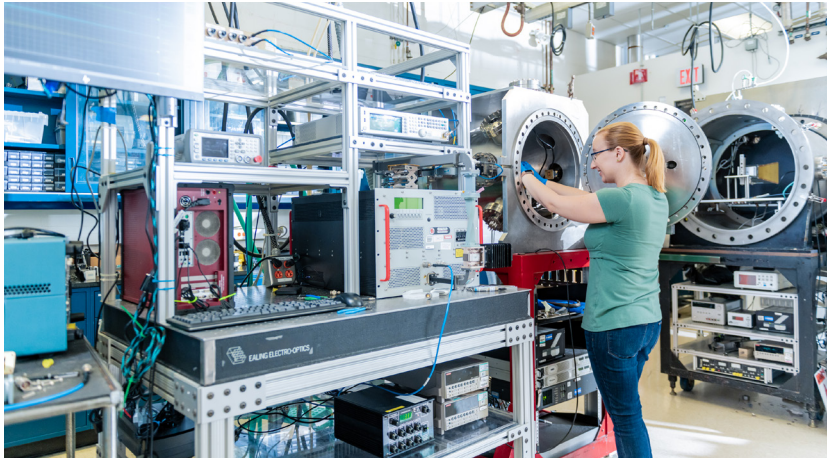

The multipactor lab has multiple test facilities capable of testing a wide variety of hardware at high power.

Multipactor is a type of electrical breakdown that occurs in high-power radio frequency (RF) and microwave systems in vacuum. It can cause signal degradation and hardware damage. In recent years, improvements in solar cell efficiency have given us increases in onboard power that introduce breakdown problems in frequency regimes that previously were too high for breakdown. Numerous programs have suffered serious issues as industry analysis and test techniques have struggled to identify problems early in the hardware development phase. The Aerospace team has the experience, technical knowledge, and cross-departmental collaborations to address problems quickly.

Our research focuses on the fundamental physics of breakdown targeted towards our customers' current and future needs – complex signals, breakdown sensitivity to RF pulse profile, and advanced materials Secondary Electron Yield (SEY). We have also developed a state-of-the-art modeling tool which has unique capabilities that are unavailable in the current analysis codes on the market. This new tool, the Systematic Multipactor Research Tool (SMRT) can provide more accurate analysis and capture complex physics that affect the severity of breakdown issues. This means we can predict breakdown location, power level, and severity.

The ability to rapidly verify flight hardware against multipactor is key to ensuring mission success in a rapidly changing and evolving space enterprise. We develop state-of-the-art test techniques and analysis tools to help solve problems faster than anyone else. We have the best lab in the nation with the most sensitive diagnostics for performing rapid breakdown performance evaluation and root-cause identification.

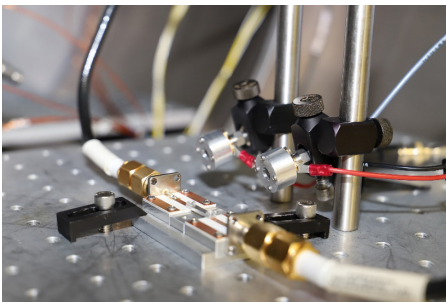

A full suite of state-of-the-art diagnostics enable breakdown detection and root cause identification.

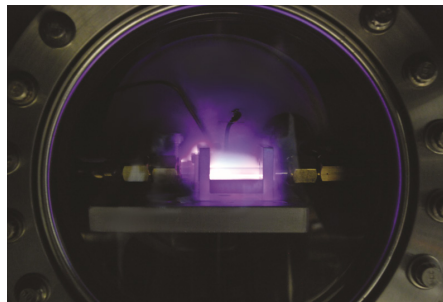

A sample experiencing RF plasma breakdown, which can be particularly damaging to spacecraft components and systems.

KEY CAPABILITIES:

- Multiple TVAC chambers
- Secondary electron yield measurement
- State-of-the-art diagnostic suite
- Commercial-and-research grade predictive tools
- High-power test capability up to 1 kW
 - › 100 MHz – 9 GHz
- Anechoic Test Facility

SPACE BATTERIES



Technology
Development and
Prototyping



Advanced
Concepts



Rapid and Agile
Acquisitions

The availability of stored energy is critical to provide electrical power to launch and space vehicles when energy from solar arrays is insufficient. Energy storage devices such as batteries are often a significant portion of the vehicle mass and can be the life-limiting components of a spacecraft. Higher energy or power density can also enable certain missions. Our lab tests, evaluates, and analyzes battery performance in relevant space environments, supporting the spectrum of high-fidelity to agile missions.

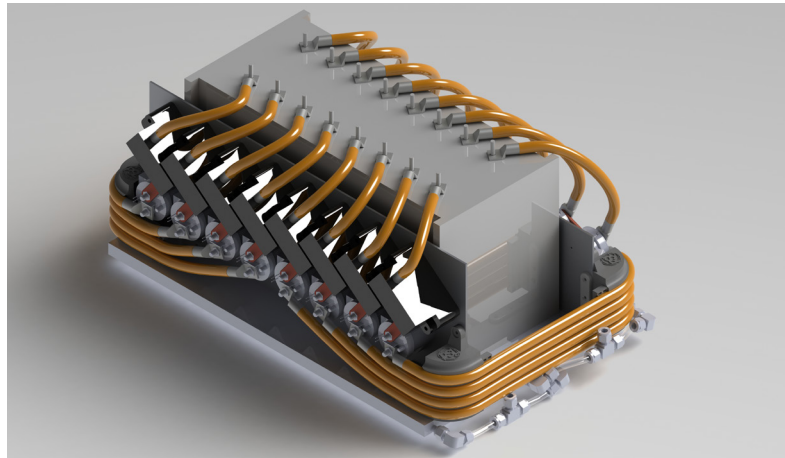

CAD model of battery test fixture assembly.

The Battery Evaluation Lab has been testing space batteries for decades, starting with nickel cadmium, then nickel hydrogen, and now lithium-ion cells for space vehicles. We also test and have expertise in a variety of primary (non-rechargeable) cell technologies. We employ a team of engineers, technicians, and scientists to design, build, and interpret battery tests in support of national security space.

Using in-house designed battery test software and hardware, we can develop a program-specific battery test. Applying test-as-you-fly principles, we subject batteries to electrical, thermal, and mechanical conditions simulating on-orbit conditions, while measuring detailed telemetry to understand battery performance and degradation over time. This data is valuable for on-orbit trending and anomaly resolution. Custom software and hardware configurations allow us to adapt tests to the customer's needs

Proliferated systems and space resiliency are resulting in increased usage of commercial off-the-shelf (COTS) cells for space. We are building a library of data for COTS Li-ion cells, trending their performance in orbital conditions and accelerated conditions to enable more agile battery acquisition. We use non-destructive test techniques to assess cell performance, increase confidence in cell reliability, and identify counterfeit parts. We can also destructively evaluate cell physical degradation modes, linking them to electrochemical performance. We are also developing better prediction techniques by investigating machine learning models and looking towards next-generation batteries and hybrid systems for improvements that can enable new mission capabilities.

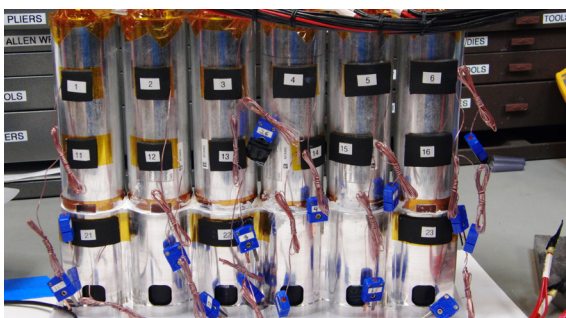

The Battery Evaluation Lab has an extensive history with a wide range of space battery technologies.



COTS Li-ion cells in test fixtures.

SPACECRAFT CONTAMINATION



Rapid and Agile
Acquisitions

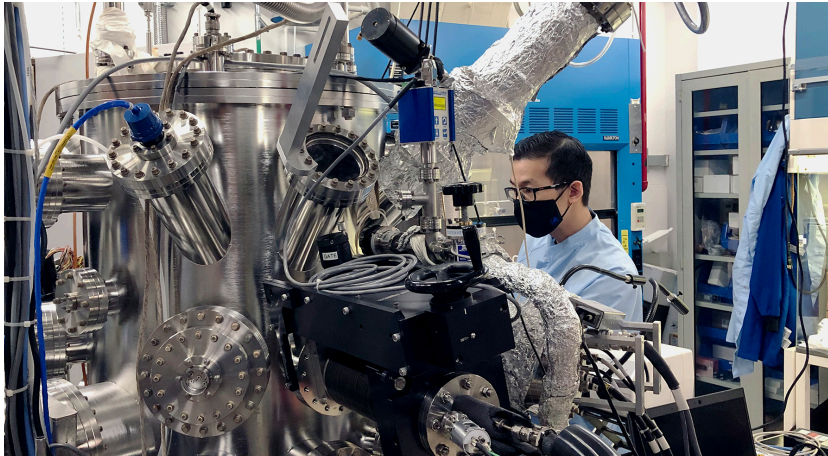

In-situ molecular contaminant characterization and material outgassing testing using the Contamination Effects, Research and Testing (CERT) chamber.

Contamination control plays a key role in mitigating performance degradation for space systems such as optics, solar arrays, and thermal control systems. Spacecraft contamination phenomena can be complex, requiring an understanding of the physical and chemical processes governing contaminant generation, transport, and effects on system performance. The Spacecraft Contamination group draws on decades of cross-program experience and strong industry partnerships to provide timely and expert support to U.S. space programs.

As the leader in the aerospace industry, the Spacecraft Contamination group possesses highly specialized testing and analytical

capabilities. The laboratories are equipped with state-of-the-art facilities capable of studying contaminant transport and deposition in flight-like environments. The test facilities are equipped to characterize the physical, chemical, and optical properties of contaminant films simultaneously, which provides scientific insights into molecular-surface interactions in the space environment.

Where laboratory testing is limited, finite element transport simulations are used to assess contamination in complex space systems, and to enable rapid diagnostic analyses. This capability has been used to elucidate key physical factors contributing to contaminant transport phenomena.

The Spacecraft Contamination group's unique capabilities have been utilized to address contamination issues, to perform anomaly root-cause investigations, as well as to provide independent contamination risk assessments.

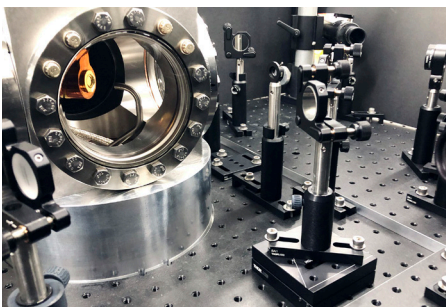

Optical Interference of Contamination Effects (OICE) chamber for in-situ and real-time characterization of molecular film growth and optical properties.

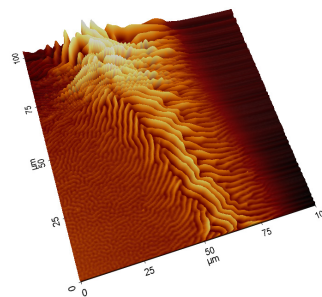

Atomic force microscopy image of the surface morphology of a silicone contaminant film.

KEY CAPABILITIES:

- Material outgassing testing
- Particulate contaminant characterization
- Molecular contaminant analysis
- Contaminant surface interaction analysis
- Transport modeling

SPACE DOMAIN AWARENESS



Resiliency and Space
Warfighting R&D

As more nations have advanced space capabilities, it becomes increasingly critical for the U.S. to be cognizant of what else is operating in space, an area known as Space Domain Awareness (SDA). However, the current SDA enterprise is not integrated. Data does not flow smoothly from photons to decision support tools for the warfighter, which means we are responding too slowly.

Space control and SDA is a technically challenging problem with many requirements: extensive sensor networks for observational capacity, geometric diversity for solar lighting conditions, broad ground sensor coverage, and response times on a tactical scale. Aerospace's SDA team is uniquely qualified to address all these issues to improve data flow and decision speed.

One foundational issue is how to use multiple heterogeneous sensors to collect data on a plethora of targets. This requires scheduling sensors, communicating observational tasks to them in real time, acquiring these observations autonomously, and reporting the data back to a central data store. Scheduling is a particularly complex problem with many variables, since the sensors, targets, Earth, and sun are all in relative motion. Artificial intelligence/machine learning is a promising solution path that can be leveraged to meet the timescales we need.

Aerospace is leading the way in establishing an operational pipeline for SDA sensors with project Prime Focus – a prototype automated SDA node. Prime Focus will automate the 1-m AeroTel telescope located at our El Segundo facility. User inputs will generate an automated observation schedule that can account

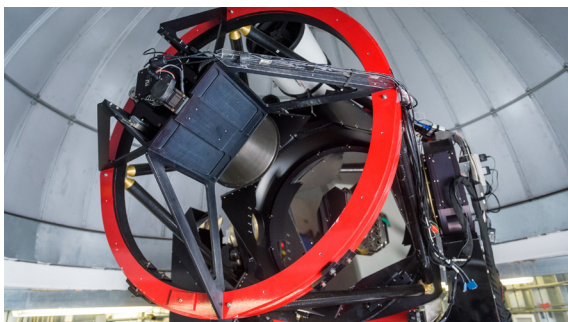

AeroTel, a 1-meter telescope located at our El Segundo campus, serves as the sensor testbed for project Prime Focus.

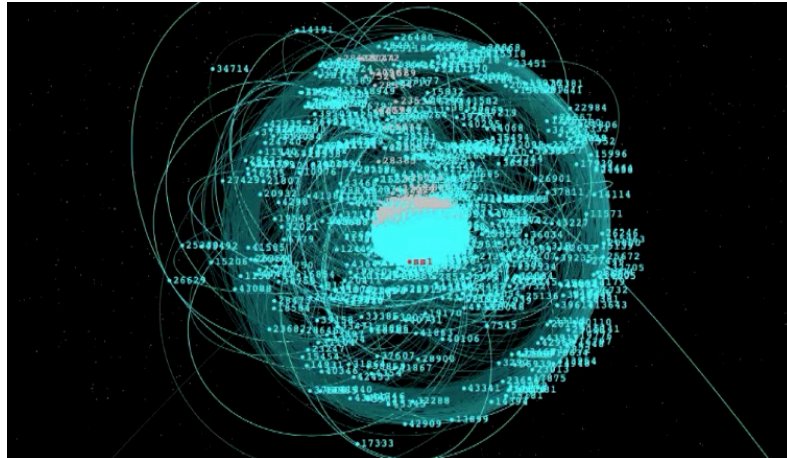

SDA will require artificial intelligence/machine learning solutions as the space environment grows more contested and congested. The Aerospace SDA team is pioneering new approaches to these challenging problems.

for light conditions, and then report data products to the users automatically. The node relies on cloud infrastructure, cloud storage, and software management that is aligned with modern software practices. This demonstration can then be scaled to fill the SDA need to coordinate large numbers of sensors with multiple targets.

SPACE ENVIRONMENTAL EFFECTS



Rapid and Agile
Acquisitions

The space environment is an operational regime that can be challenging to even the most robust materials. The Space Environmental Effects (SEE) lab has established a multi-decade history of space environmental effects testing and evaluating the performance of spacecraft materials in many orbital environments.

The SEE Lab maintains multiple state-of-the-art exposure facilities dedicated to high-fidelity simulation of space environment effects. Each ultrahigh vacuum facility features multiple radiation sources (broadband and vacuum ultraviolet illumination, 1–100 keV electrons,

2–100 keV protons) and vacuum-compatible in situ spectrometers (230–1100 nm transmittance, 250–2800 nm reflectance). Recently, a vacuum-compatible infrared (2–6 mm) spectrometer system was added; this measurement capability is new to the field of space environment effects testing. The facilities are designed to operate 24/7 during exposure tests, which can last for months at a time.

The SEE Lab's exposure facilities are regularly employed to perform accelerated laboratory test programs that simulate the effects of space radiation environments in a variety of surface spacecraft materials:

- Thermal control materials
- Optics and optical coatings
- Solar cell cover glass materials
- Radome materials

The SEE Lab supports a wide range of national security space programs by providing high-fidelity material performance data. The SEE Lab continues to expand its capabilities to meet the growing demands of our customer base.

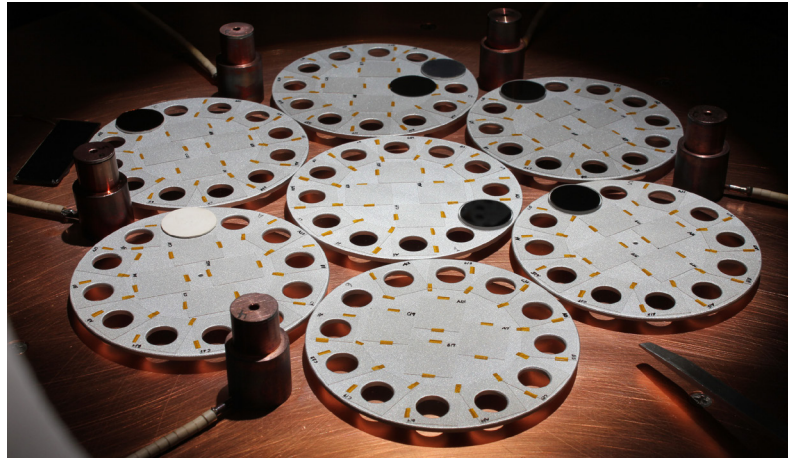

A matrix of solar cell coverglass samples under test in the exposure facility.

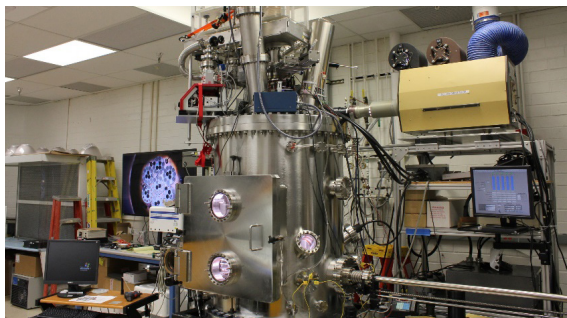

A space environmental effects exposure facility used to perform accelerated simulated space radiation exposure testing and characterization of materials.



These materials were exposed to laboratory-simulated space radiation for a period of 14 years.

SPACE PHOTOVOLTAICS



Technology
Development and
Prototyping



Rapid and Agile
Acquisitions

Solar cells generate power for all Earth orbiting satellites and limit how long you can operate your satellite and how many capabilities it has. The solar array is also typically the largest component of the satellite, which makes it more susceptible to damage in orbit. Our lab seeks to characterize, understand, and improve all components of the solar array to increase the resiliency of our satellites in the space environment.

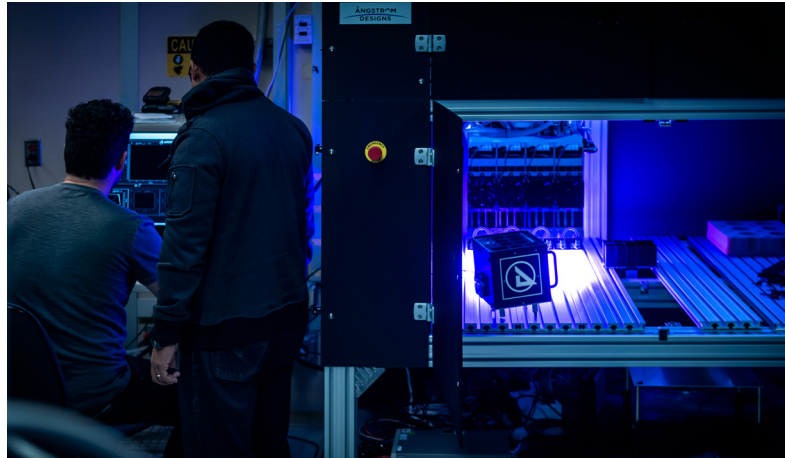

An LED-based solar simulator used to characterize CubeSat solar panels.

Aerospace has a world-class space photovoltaic evaluation and research laboratory for spacecraft power generation and resilience applications. We combine state-of-the-art laboratory capabilities, expertise in foundational science and technology, cross-program and industry knowledge, and expansive vision of missions to support and lead innovation in the industry.

Aerospace has been evaluating space solar array performance since our founding in 1960. As space solar cells have advanced in performance, Aerospace has been at the forefront of development and research, partnering with industry and customers to advance the technology and capabilities to provide the most accurate and objective comparisons between technologies.

As space acquisition cycles become shorter, our state-of-the-art laboratory capabilities for solar cell characterization and our patented near-space solar cell calibration platform enable us to meet the needs of any advanced solar cell technology development in a rapidly changing space enterprise.



Our scientists use this proton accelerator to simulate proton radiation from space, which is one of the main causes of solar cell failure.

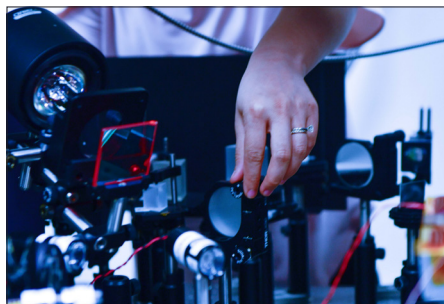

Aerospace is funding an R&D project to use a supercontinuum laser to simulate the exact spectrum of the sun.



The custom Xe-lamp based solar simulator is highly tunable for measuring all advanced space solar cell technologies.

SPACE SENSORS



Technology Development and Prototyping

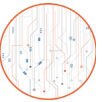

Advanced Concepts

The space environment can be harsh, particularly when it comes to radiation. A comprehensive understanding of the radiation environment is needed to support rapid anomaly assessment, reduce uncertainty in design margins, and support the growing space industrial base.

For more than fifty years the Space Sensors Laboratory has been designing, building, and launching sensors to assess the space environment. Miniaturization of these sensors has enabled more to be flown, improving models and our fundamental understanding of Earth's trapped radiation, shown right.

Spacecraft must also contend with the upper atmosphere and ionosphere, the electrically charged layer all signals must pass through from space to ground. The ionosphere may severely impact radio frequency signals, causing them to be absorbed, reflected and scattered, which can seriously disrupt mission activities.

The upper atmosphere, or more specifically the thermosphere, impacts the orbits of low-Earth orbit (LEO) satellites by causing drag. The 3D wave-like variations observed in the upper atmosphere impact satellite re-entry predictions, potential collision predictions, and precise orbit positioning.

The Space Sensors Laboratory develops sensors to study all these effects, with instruments that image atmospheric waves both from the ground and from space. Recent CubeSat developments also aim to image the upper atmosphere from LEO and perform measurements of the ionosphere using techniques such as GPS radio occultation.

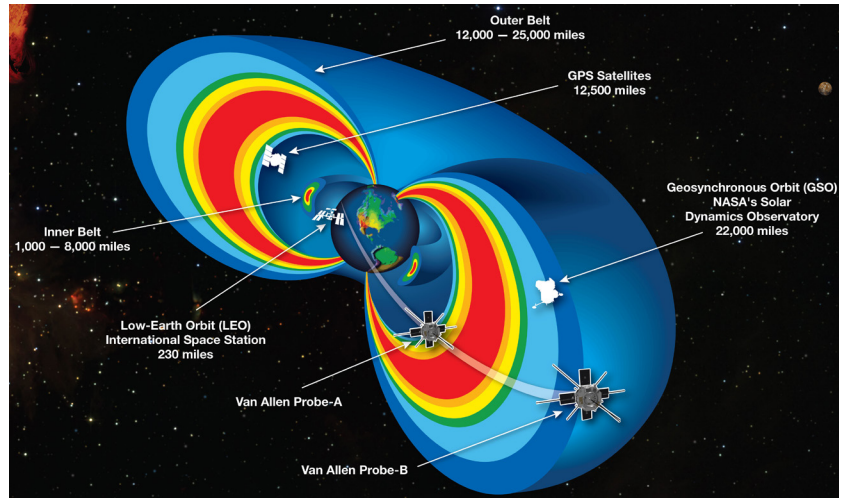

A cutaway model of the radiation belts. Illustration courtesy NASA.

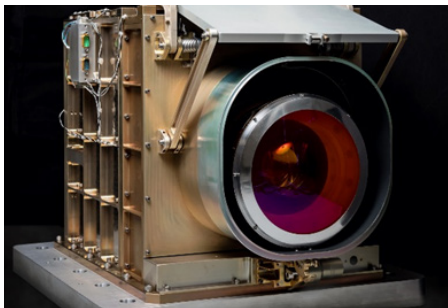

PIANO

Phenomenology Imager & Nighttime Observer (PIANO) is a prototype low-light imager supporting LEO weather and overhead persistent infrared augmentation missions on the International Space Station.

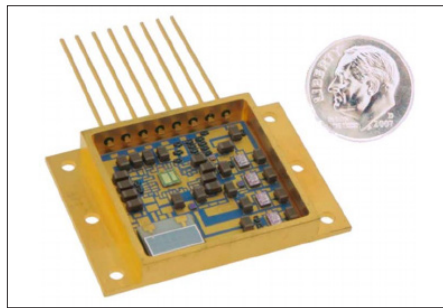

Microdosimeter

The Aerospace-developed Teledyne microdosimeter, a step forward in the miniaturization of radiation instrumentation, has been included in numerous space missions to better characterize the radiation environment.

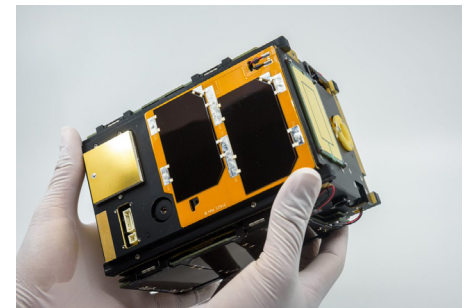

LLITED

The Low-Latitude Ionosphere/Thermosphere Enhancements in Density (LLITED) mission is two 1.5U CubeSats that will measure and study the nighttime upper atmosphere.

THIN FILMS AND OPTICAL COATINGS



Technology Development and Prototyping



Advanced Concepts

Multilayer optical coatings are essential elements of almost every spacecraft since they are used in sensor systems, thermal control strategies, and photovoltaic power sources. Meeting the performance and durability specifications for advanced optical coatings requires detailed knowledge of the correlation between the thin-film deposition process and the resultant film properties. In addition, accurate modeling of the space environment and high-fidelity simulation of space environmental effects on optical coatings are crucial for all space missions.

This laboratory combines thin film deposition and testing capabilities and expertise with our world-class Space Environmental Effects Lab test capability. This unique combination of facilities and cross-field knowledge enables Aerospace to independently assess the performance of optical coatings being acquired for current and future national security space programs. Our approach is to fabricate and test thin film materials in one integrated program. This gives us a unique opportunity to develop best coating techniques and practices based on measured performance in various simulated environments.

The performance and durability of optical coatings are highly dependent on optimal coating processes. Our coating facilities feature multiple state-of-the-art sputter deposition systems that include high-efficiency reactive gas controls to significantly enhance the quality of dielectric coatings. A new double-planetary substrate fixture has been installed in our Plasma Beam Sputtering System to improve coating uniformity across large optics. Additionally, a new space environmental exposure facility is currently being integrated to meet the high demand from our customers.

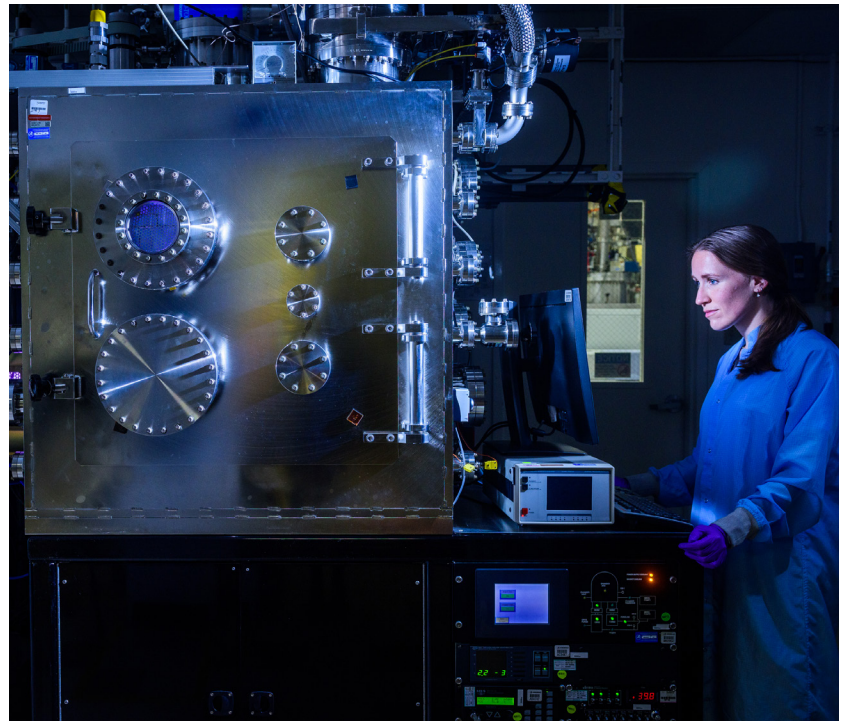

A scientist operates Aerospace's custom Plasma Beam Sputtering System.



Example of dark mirror antireflection coating deposited at Aerospace.

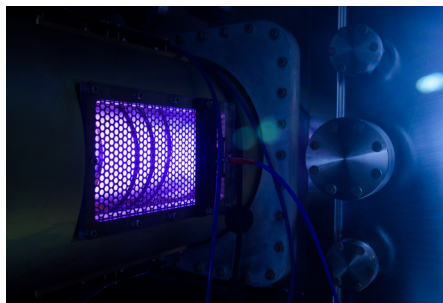

The custom Plasma Beam Sputtering System uses an RF plasma source (the purple region) to synthesize advanced optical coatings.

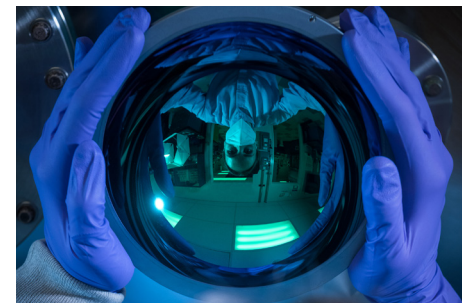

Example of an advanced optical coating deposited on a curved substrate.

***TECHNOLOGY
HIGHLIGHTS***

ANOMALY ATTRIBUTION TOOL SUITE

SPECS:

TRL: 8-9

MISSIONS: Space Domain Awareness Environmental Toolkit for Defense (SET4D)

The natural space environment can cause satellite anomalies that can be misconstrued as adversary action. Rapid determination of the source of an anomaly is essential for prompt and appropriate mission response. It can also be used to advise or modify operations to mitigate system hardware weaknesses. Historically, anomaly attribution has been accomplished over days to weeks by gathering data and performing expert analysis by hand. To expedite these timelines, Aerospace developed a suite of Anomaly Attribution Tools (AATs) for determining the likelihood of an anomaly due to surface charging, internal charging, single event effects, or event total dose in any Earth orbit by correlating the time and location of the satellite with space weather data.

The AATs source data from National Oceanic and Atmospheric Administration spacecraft such as Geostationary Operational Environmental Satellites (GOES), Polar Orbiting Environmental Satellites (POES), the European Meteorological Operational satellite (METOP), solar wind velocity, geomagnetic activity indices, magnetic coordinates and local times. These data are then processed in automated web app flow charts. The user need only enter the time and location of the anomaly and satellite ID. The tool returns the likelihood that an anomaly was the result of local space weather effects.

The AATs can unify ground and operations communities onto a single anomaly resolution platform and can evolve as analysts and end users provide feedback on what capabilities are needed. The suite’s capabilities include:

- **Energetic Charged Particle (ECP) Hazard Assessment System (HAS) Flow Chart (FC)** assesses the likelihood the anomaly could have been caused by one of the four traditional ECP anomaly types.
- **Space Environment Electro-Magnetic Interference Flow Charts (SEEMI FC)** evaluates whether communication outages are due to EMI from an elevated space environment or specific weather conditions.
- **Long-term Environmental Anomaly Forecast (LEAF)** provides probabilistic forecasts of the space environment projected 7 days ahead to be used as inputs to generic and vehicle-specific anomaly probability forecasting.



The Anomaly Attribution Tool Suite helps determine if anomalies are due to the space environment by correlating the time and location of anomalies with space weather conditions. Photo courtesy NASA.

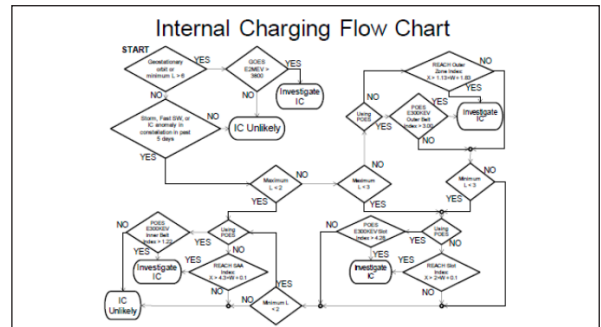

AAT Flow Charts

Example AAT decision flow charts for attributing anomalies due to internal charging. Similar charts exist for surface charging and single event effects, as well as electromagnetic interference effects that can disrupt communications.

/// TECHNOLOGY HIGHLIGHT

BATTERY DEORBITER

SPECS:

TRL: 2 3

MISSIONS: ISS

The population of satellites in low-Earth orbit (LEO) is expected to rapidly rise over the next decade, causing a higher risk of space debris-forming collisions between active satellites, inactive satellites, or other space debris. A reduction of space debris is needed to preserve LEO. The Battery Deorbiter concept is a low-cost, low-mass satellite enhancement for safely reducing the residual orbit lifetime at the end of a satellite's active mission. The technique uses existing on-board lithium-ion batteries to generate directed thrust by deliberately sending them into thermal runaway and channeling the resulting gasses. The method does not require additional propulsion systems or resources. Furthermore, it eliminates the batteries as a source of stored energy at spacecraft end-of-life that could result in additional orbital debris.

Competing deorbit technologies such as tethers and thrusters add to spacecraft mass and volume. The Battery Deorbiter concept enables directed thrust to expedite orbital decay by using resources already onboard. This approach is a first-of-its-kind spacecraft technology capable of reducing orbital debris and helping to protect low Earth orbit from higher risk of collision.

The Battery Deorbiter is intended for use on small sats, which often have no onboard propulsion and rely on atmospheric drag to eventually de-orbit. By using the spacecraft's onboard batteries as a propulsion unit, the overall lifetime and chance of collision can be drastically reduced once the mission is complete by quickly removing the spacecraft from orbit. Furthermore, the Battery Deorbiter technique could potentially increase the range of orbital altitudes available to small sats by enabling them to meet Federal Communications Commission requirements on maximum residual orbital lifetime without the need for a separate propulsion system.

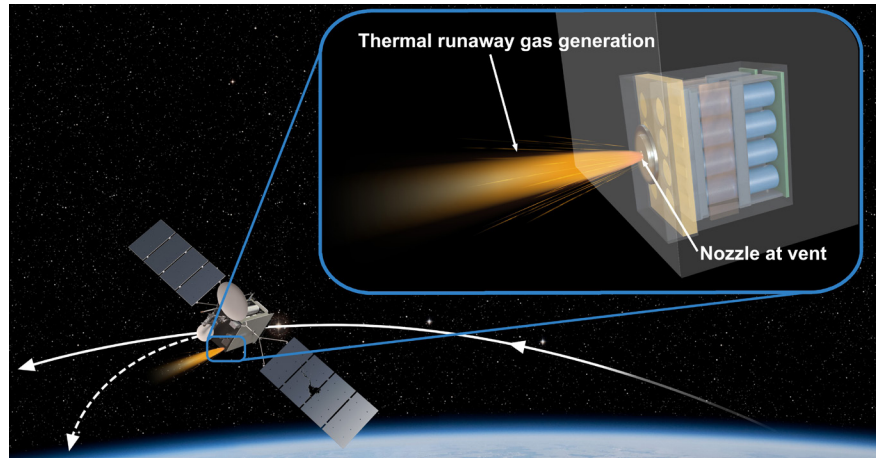

As the number of satellites in LEO continues to grow, the risk of space-junk forming collisions also increases. The Battery Deorbiter can safely deorbit assets at the end of their mission life without requiring additional propulsion resources.

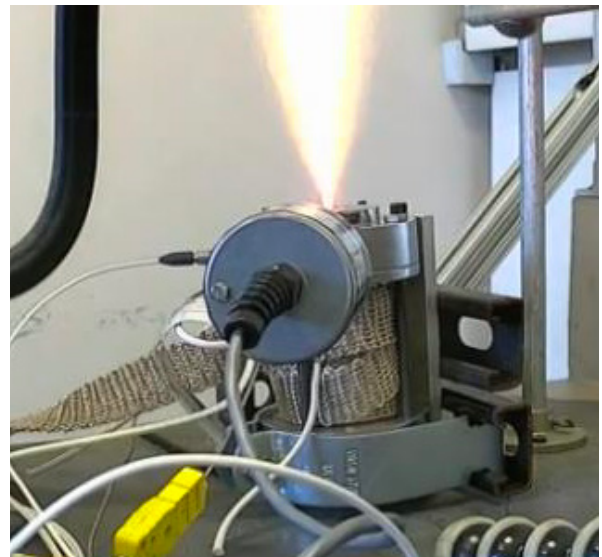

Thrust From Onboard Energy Storage

Sending a lithium-ion battery into thermal runaway can produce thrust that can control the deorbit of a small satellite.

/// TECHNOLOGY HIGHLIGHT

CATCHER

SPECS:

SWAP: 6" x 7" x 4", 4.0 kg, 9 W

TRL: 5-6

MISSIONS: Long Duration Propulsive ESPA (LDPE)-3A

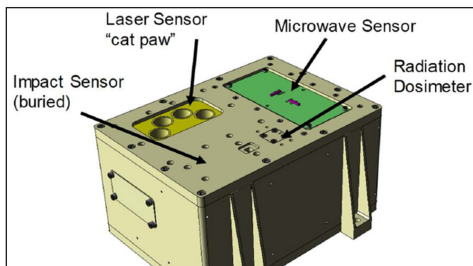

Catcher physical design and sensor layout.

In the increasingly congested space environment, there is a need for timely attribution of natural and man-made threats. The ability to quickly detect and characterize intentional denial and disruption events can require multiple sensors that not only take up significant resources and exceed accommodation limits but may also require development time that lags the changing threat environment. Catcher is a low-SWaP-C sensor that supports timely attribution of events by characterizing quiet-day operations and providing level and time of occurrence of non-nominal environments.

Catcher provides threshold detection of space hazards for host operations and tip and cue information for other systems. It employs an architecture that allows for the modification of its 4 sensors for follow-on flights. The sensor suite is composed of:

- Laser sensor: Detects and counts laser pulse impingement from 532, 1064, and 1550 nm
- Microwave sensor: Detects and counts microwave pulse impingement from 5 – 18 GHz
- Impact sensor: Detects and counts acoustic emissions resulting from kinetic impacts
- Radiation dosimeter: Provides radiation dose data for anomaly attribution

Catcher's low-SWaP package, simple interfaces (electrical, mechanical, data), and radiation hardness (15-year design life at GEO) permits it to be easily hosted on a variety of platforms across all orbits. A distributed network of Catcher's can establish space situational awareness of the contested space environment.

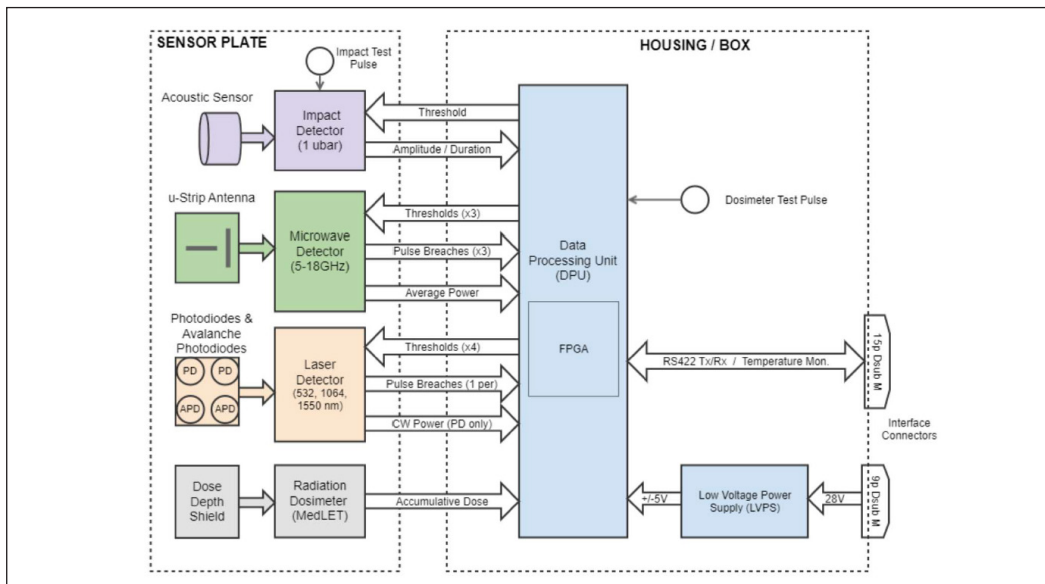

The Catcher block diagram shows how it leverages a configurable sensor plate with SDA sensors on a housing with a common data and power unit.

/// TECHNOLOGY HIGHLIGHT

MICRO CHARGED PARTICLE TELESCOPE (μ CPT)

SPECS:

SWAP: 7.6 cm × 4.8 cm × 4.1 cm; Mass 0.268 kg;
Power 0.368 W

TRL: 7

MISSIONS: AeroCube-10

μ CPT is a configurable space environment monitoring payload that can provide high resolution data for anomaly attribution. It provides situational awareness of charged particle-related space weather hazards to a spacecraft in a low size, weight, and power (SWaP) instrument.

μ CPT was first developed to provide particle flux data to the AeroCube-10 mission, but its small form factor and extensive adaptability make it easy to integrate on almost any size spacecraft that requires environmental data.

μ CPT provides detection capabilities that complement or are more accurate than other energetic charged particle (ECP) environmental monitors (CEASE3, REACH, ECP-Lite). ECP species can be separated and resolved by the μ CPT to monitor internal charging hazards and total event dose, and detection thresholds are tailorable by orbit, particle species, and environmental hazard. The μ CPT's small form factor enables flexible integration to space systems so the space environment can be monitored from multiple look angles or for a variety of energy ranges.

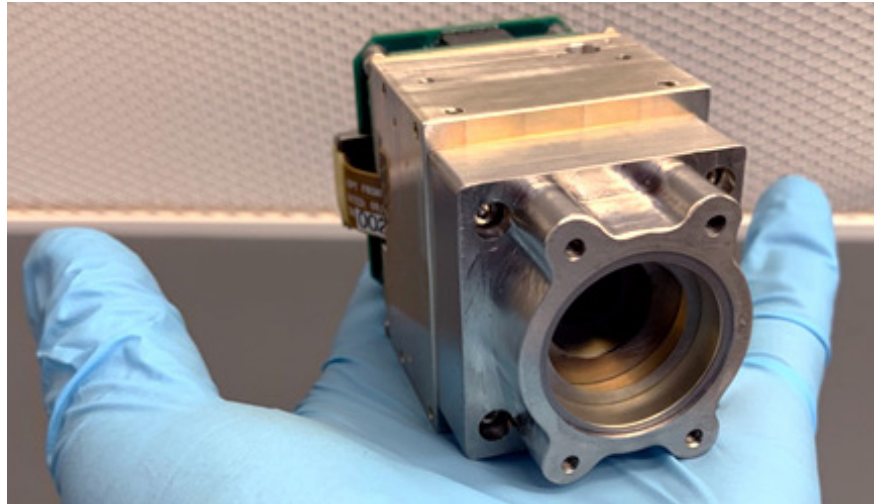

The μ CPT instrument is a low SWaP solution for measurements of the charged particle environment on orbit.

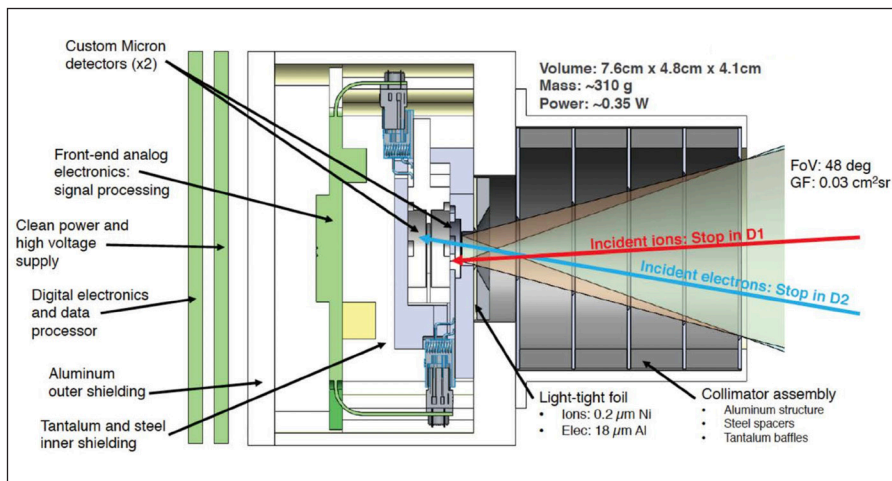

Versatility in a Small Package

μ CPT measures low energy protons (0.08–1 MeV), high energy protons and isotopes H⁺, 2H, and 3H (1.5–3.9 MeV), Alpha particles (1.0–4.0 MeV), and electrons (0.1–2.5 MeV). These energy ranges are configurable based on mission needs.

/// TECHNOLOGY HIGHLIGHT

MONOCLE



The MONOCLE prototype pictured here can shepherd in a new era of ground-based telescope to keep up with the rapidly increasing number of space assets.

Its novel design features transcend existing limitations of ground-based telescope, and its wireless communication permit it to be operated remotely. Development of a network of MONOCLES will provide “unfettered access to space” and ensure observational capacity of RSOs keeps pace with the ever-growing number of vehicles on-orbit.

SPECS:

SWAP: < 50 kg, 35 W

APERTURE SIZE: 0.125–1 m

TRL: ● 3 ● 4 ●

PATENT ACCEPTED 2021 AUGUST

The number of resident space objects is growing exponentially, while the number of ground stations available to access them is growing linearly. The implications of this scaling law mismatch are a lack of observational capacity for space domain awareness and a communication bandwidth bottleneck for free space optical communication to resident space objects (RSO).

MONOCLE is an automated, environmentally shielded, electro-optical ground telescope that enables a network sensor approach.

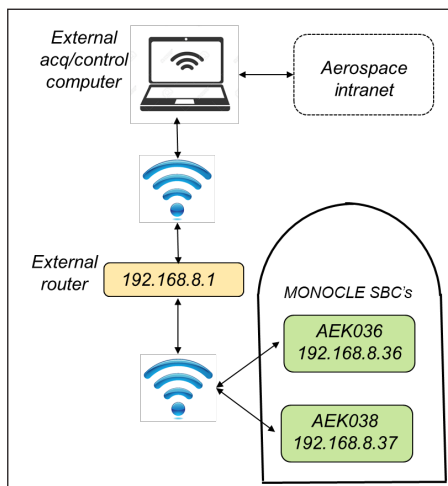

Remote and Autonomous Operation

MONOCLE’s wireless commanding and scheduling permits it to be placed in inaccessible locations and operated remotely.

Requirement	MONOCLE Design
Operable in adverse environmental conditions.	Enclosed dome design protects telescope and instrumentation from weather, contaminants, wildlife.
Operable over a wide range of temperatures.	Sealed dome design for temperature control via external HVAC.
Stray light suppression to reduce light pollution, mitigate laser jamming.	Baffled mounting located on the dome.
Ensures laser broadcast safety.	Hardware limits precludes laser broadcast below limiting elevation angle.
Tracks RSO’s in LEO, MEO, GEO.	Two-axis rotation design employed for pointing/tracking.
Replicable, low-cost design scalable to larger apertures.	COTS parts: rotary encoders and motors, single board computers, GPS/IMU, telescope optical tube assembly and camera. Scales to ~1.5 m apertures.
Network-based command/control/data retrieval to support distributed sensor network.	Network-based command/control/data retrieval to support distributed sensor network.

/// TECHNOLOGY HIGHLIGHT

PHENOMENOLOGY IMAGER & NIGHTTIME OBSERVER (PIANO)

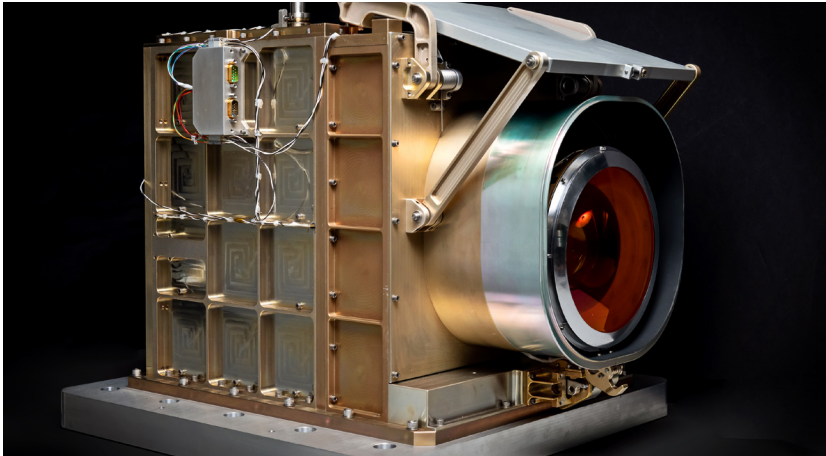

PIANO uses airglow to perform nighttime imagery in almost complete darkness. It is scheduled for installation on the ISS in December of 2021.

SPECS:

SWAP: 19"×21"×15", 45 kg, 45 W, 15 Mbps

TRL:  5 6

MISSIONS: ISS

PIANO (Phenomenology Imager and Nighttime Observer) is a prototype low-light imager supporting low-Earth orbit weather and Overhead Persistent Infrared (OPIR) augmentation missions as a technology demonstration on the International Space Station (ISS). PIANO uses airglow — faint light emission from the Earth's atmosphere — for imagery at 1.4–1.71 microns, and thermal signatures of dim targets. This means that

PIANO can collect nighttime imagery even in no-moon conditions. PIANO will be the first spaceflight of a Teledyne H4RG focal plane array.

PIANO is a follow-on technology to the Near Infrared Airglow Camera (NIRAC), which currently flies as a technology demonstration on the ISS. Compared to NIRAC, PIANO provides a larger format focal plane array, enhanced performance in all lighting conditions, and new tomographic algorithms for cloud characterization.

PIANO can image perennially dark areas with only airglow as the source of illumination, whereas existing electro-optical/infrared sensors require at least a quarter moon to perform nighttime imaging. PIANO also features a novel, patented motion compensation system for in-track (orbital) and cross-track (Earth rotation) motion during longer exposures.

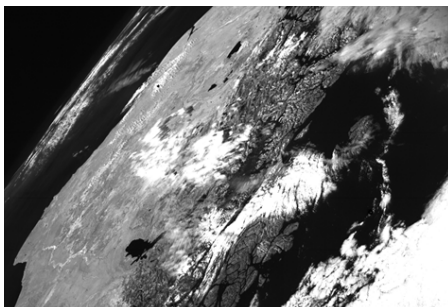

Daytime Limb View from NIRAC

This view, taken by NIRAC in March 2021, shows the darker vegetated and glaciated areas of the iconic Parque Nacional Laguna San Rafael in Patagonia, Chile, as well as the drier inland areas across Argentina (right of center) under partially cloudy skies.



NIRAC Images California Wildfire

The above is a 1.6 micron image taken October 2020 of the Red Salmon Complex fire. The white area shows hot regions and active fires. Sun-illuminated, low-albedo surface features appear in varying shades of gray.

PIANO addresses multiple factors that are needed for cloud characterization algorithm development including cloud cover, cloud height, and cloud optical depth. Height maps can be derived from day and night image sequences showing convective features, circulation patterns, low clouds and fog.

/// TECHNOLOGY HIGHLIGHT

pLEO BEACON

SPECS:

Configurations: Mini (Hand-Carry) and Mobile (Truck)

TRL: 7



The small form factor of the mini-beacon makes it ultra-portable for operation at a single wavelength in the shortwave infrared band.

Proliferated low Earth orbit (pLEO) constellations will be increasingly employed in the near future. As with all on-orbit imaging sensors, they will require careful calibration and validation, perhaps with new modalities — on demand, over inaccessible locations, and with increased frequency. On-orbit calibration is typically performed by ground beacon terminals, but future pLEO needs must be addressed with more compact and efficient laser systems that can be packaged for novel mission scenarios with non-traditional infrared lines.

Aerospace’s mobile beacons are self-contained optical systems integrated in cargo trucks that can be configured to specific wavelengths and simultaneously transmit multiple wavelengths. At an even smaller form factor, Aerospace’s mini-beacons are highly portable and operate at a single wavelength in the shortwave infrared band.

Aerospace has a long history of developing laser beacon systems for on-orbit satellite calibration. Aerospace has also been working extensively on advanced laser solutions that allow for wavelength and waveform agility. The expertise and experience Aerospace has accumulated since the 1970s has led to the development of laser beacon technology to support the temporal and spatial calibration of pLEO systems.

Demonstrated feature	Mobile	Mini
Open-loop pointing	X	X
Multiple simultaneous wavelengths	X	
Modulated waveform	X	X
Field deployment	X	X
GPS-timed signals	X	
Extended/multiple source	X	X
Remote operation	X	



Our self-contained mobile beacons have been taken across the world for mobile satellite calibration.

